

INSTRUCTION MANUAL
MODEL 166
**50 MHz PULSE/
FUNCTION GENERATOR**

WAVETEK
SAN DIEGO

9045 BALBOA AVENUE, SAN DIEGO, CALIFORNIA

INSTRUCTION MANUAL
MODEL 166
**50 MHz PULSE/
FUNCTION GENERATOR**

© — 1978 — Wavetek

THIS DOCUMENT CONTAINS INFORMATION PROPRIETARY TO WAVETEK. THE INFORMATION IN THIS DOCUMENT IS NOT TO BE USED OR DUPLICATED IN ANY MANNER WITHOUT THE PRIOR APPROVAL IN WRITING OF WAVETEK.

WAVETEK®

SAN DIEGO

9045 Balboa Ave., San Diego, Calif. 92123
P. O. Box 651, San Diego, California 92112
Tel 714/279-2200 TWX 910-335-2007

Manual Revision 3/80
Instrument Release F-3/80

WARRANTY

All Wavetek instruments are warranted against defects in material and workmanship for a period of one year after date of manufacture. Wavetek agrees to repair or replace any assembly or component (except batteries) found to be defective, under normal use, during this period. Wavetek's obligation under this warranty is limited solely to repairing any such instrument which in Wavetek's sole opinion proves to be defective within the scope of the warranty when returned to the factory or to an authorized service center. Transportation to the factory or service center is to be prepaid by purchaser. Shipment should not be made without prior authorization by Wavetek.

This warranty does not apply to any products repaired or altered by persons not authorized by Wavetek, or not in accordance with instructions furnished by Wavetek. If the instrument is defective as a result of misuse, improper repair, or abnormal conditions or operations, repairs will be billed at cost.

Wavetek assumes no responsibility for its product being used in a hazardous or dangerous manner either alone or in conjunction with other equipment. High voltage used in some instruments may be dangerous if misused. Special disclaimers apply to these instruments. Wavetek assumes no liability for secondary charges or consequential damages and, in any event, Wavetek's liability for breach of warranty under any contract or otherwise, shall not exceed the purchase price of the specific instrument shipped and against which a claim is made.

Any recommendations made by Wavetek for use of its products are based upon tests believed to be reliable, but Wavetek makes no warranty of the results to be obtained. This warranty is in lieu of all other warranties, expressed or implied, and no representative or person is authorized to represent or assume for Wavetek any liability in connection with the sale of our products other than set forth herein.

CONTENTS

SECTION 1	GENERAL DESCRIPTION	
	1.1 MODEL 166	1-1
	1.2 SPECIFICATIONS	1-1
	1.2.1 Versatility	1-1
	1.2.2 Sweep/Function Generator	1-1
	1.2.3 Frequency Precision	1-2
	1.2.4 Amplitude Precision	1-2
	1.2.5 Waveform Characteristics	1-2
	1.2.6 Pulse Generator	1-2
	1.2.7 General	1-3
SECTION 2	INITIAL PREPARATION	
	2.1 MECHANICAL PREPARATION	2-1
	2.2 ELECTRICAL INSTALLATION	2-1
	2.2.1 Power Connection	2-1
	2.2.2 Signal Connections	2-2
	2.3 ELECTRICAL ACCEPTANCE CHECK	2-2
SECTION 3	OPERATION	
	3.1 CONTROLS AND CONNECTORS	3-1
	3.2 WAVEFORM TIMING	3-4
	3.3 OPERATING PROCEDURE	3-4
	3.3.1 Continuous, Triggered and Gated Operation	3-6
	3.3.2 Voltage Controlled Frequency (VCG) Operation	3-6
	3.3.3 Sweep Operation	3-6
	3.3.4 Pulse Operation	3-7
	3.3.5 Voltage Controlled Amplitude (VCA) Operation	3-7
SECTION 4	CIRCUIT DESCRIPTION	
	4.1 GENERAL	4-1
	4.2 BASIC WAVEFORM DEVELOPMENT	4-1
	4.3 WAVE SHAPE AND AMPLIFICATION	4-1
	4.4 TRIGGERED AND GATED MODES	4-3
	4.5 SWEEP GENERATOR MODES	4-3
SECTION 5	CALIBRATION	
	5.1 FACTORY REPAIR	5-1
	5.2 REQUIRED TEST EQUIPMENT	5-1
	5.3 CALIBRATION	5-1
SECTION 6	TROUBLESHOOTING	
	6.1 INTRODUCTION	6-1
	6.2 ACCESS	6-1
	6.3 TEST EQUIPMENT	6-1
SECTION 7	PARTS AND SCHEMATICS	
	7.1 DRAWINGS	7-1
	7.2 ORDERING PARTS	7-1
	7.3 ADDENDA	7-1

SAFETY

This instrument is wired for earth grounding via the facility power wiring. Do not bypass earth grounding with two wire extension cords, plug adapters, etc.

BEFORE PLUGGING IN the instrument, comply with installation instructions.

MAINTENANCE may require power on with the instrument covers removed. This should be done only by qualified personnel aware of the electrical hazards.

WARNING notes call attention to possible injury or death hazards in subsequent operation.

CAUTION notes call attention to possible equipment damage in subsequent operations.

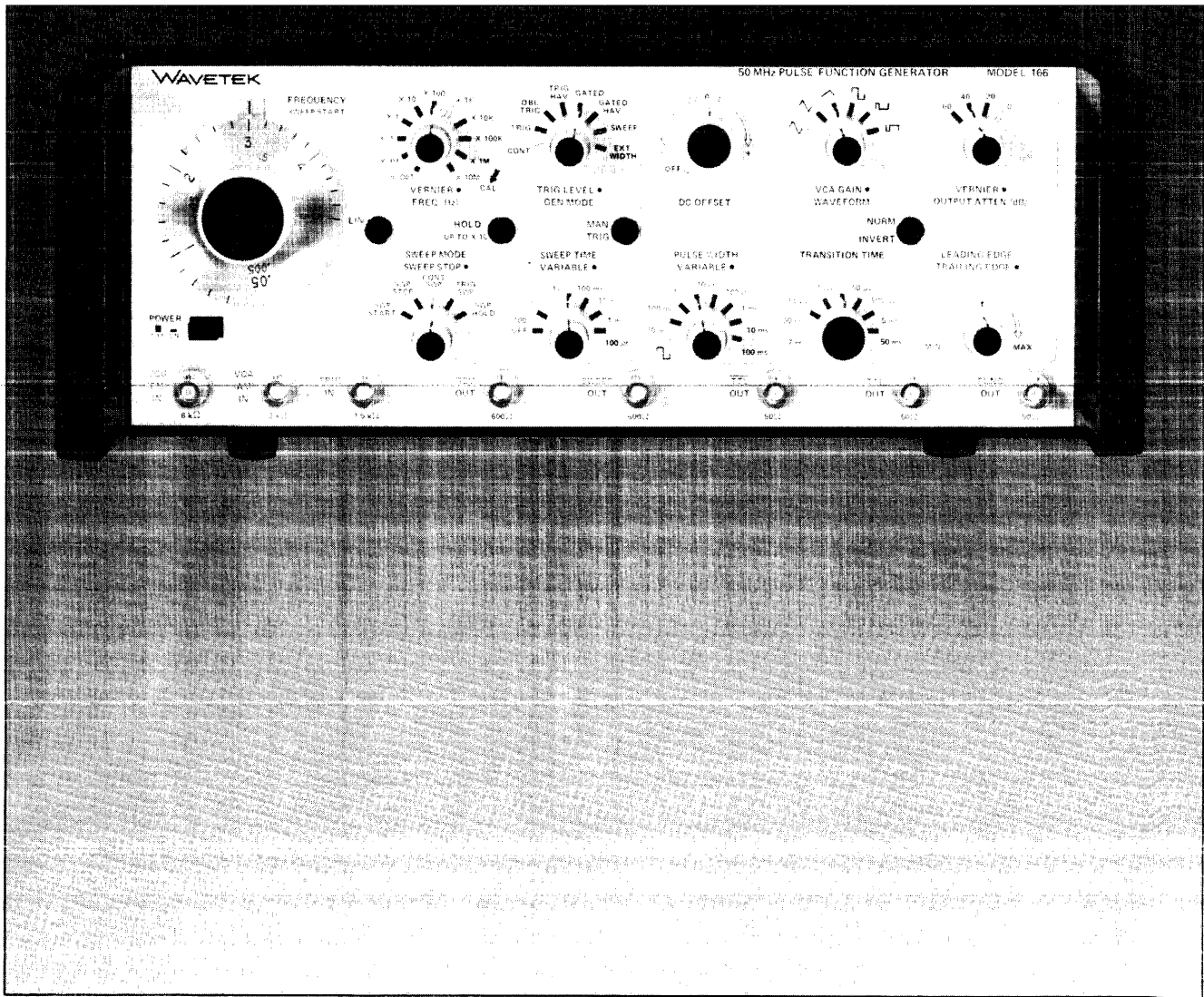

Figure i – Model 166 50 MHz Pulse/Function Generator

1

SECTION

GENERAL DESCRIPTION

1.1 MODEL 166

The Model 166 Pulse/Function Generator is a combination sweep, function and pulse generator with a full complement of features in all modes of operation. The frequency range is from 0.0001 Hz (2.8 hours per cycle) to 50 MHz. Waveforms are sine, triangle, ramp, square, pulse, positive pulse and negative pulse. The waveforms may be amplitude controlled, dc offset and inverted (complemented).

Pulse versatility includes variable width and independently variable leading and trailing edge transition times. The generator can be used to generate an output pulse whose width and frequency are dependent upon an external signal input.

Sweep can be logarithmic, as well as linear. The output can be stopped at the start and stop frequencies for accurate setting. Besides continuous sweep, a sweep may be triggered from the quiescent start frequency. The frequency can sweep to the upper (stop) frequency, then return to start frequency, or it can be held at the upper frequency. The duration of the sweep can be set to be from 100 seconds to 100 micro-seconds.

The generator can give a continuous output, be triggered for one cycle, or a double cycle, or gated for many cycles. The output waveform can be presented in haverwave mode; i.e., the selected waveform starts and stops at a positive or negative peak voltage.

The signal being generated may be frequency or amplitude modulated by external signals.





1.2 SPECIFICATIONS

1.2.1 Versatility

Instrument operates as a sweep/function generator or a pulse generator.

1.2.2 Sweep/Function Generator

Selectable Waveforms

Sine , triangle , ramp  and square . All can be inverted 180°. Ramp up-down ratio can be as large as 1:1000. All can be amplitude and frequency modulated.

Operational Modes

Continuous: Generator oscillates continuously at selected frequency.

Triggered: Generator quiescent until triggered by external signal or manually, then generates one cycle.

Double Triggered: As triggered mode, except two cycles are generated.

Triggered Haverwave: As triggered mode. Output is one cycle starting at -90° (or $+90^\circ$).

Gated: As triggered, except output continues for duration of gate.

Gated Haverwave: As gated. Output is a burst of cycles starting at -90° (or $+90^\circ$).

Continuous Sweep: Generator frequency continuously sweeps up from start to stop frequency.

Triggered Sweep: Generator oscillates at sweep start frequency until triggered, then generates one sweep to the stop frequency and returns to the start frequency.

Sweep and Hold: As triggered sweep mode, except the generator remains at stop frequency until the trigger signal falls, then returns to start frequency.

Frequency Range

0.0001 Hz to 50 MHz in 11 ranges. Maximum sweep 1000:1 in linear or logarithmic mode.

Sweep Time Range

100s to 100 μ s in 6 ranges.

Function Output

Variable to 30V p-p into open circuit (15V p-p into 50 Ω). DC offset of waveform is adjustable to ± 10 V open circuit (± 5 V into 50 Ω). Voltage attenuation 0 to 80 dB: to 60 dB in 20 dB steps, plus 20 dB continuous vernier.

Low Frequency Hold

Function output will hold at the instantaneous voltage level when the hold switch is depressed. Effective in the X 0.001 Hz to X 10 Hz ranges.

Amplitude Drift: Less than 0.2% of amplitude per minute.

DC Offset

DC offset of all waveforms is adjustable to $\pm 10\text{V}$ open circuit ($\pm 5\text{V}$ into 50Ω). Waveform plus offset is limited to $\pm 15\text{V}$ open circuit ($\pm 7.5\text{V}$ into 50Ω).

GCV Output

0 to 5V (nominal, open circuit) proportional to the frequency of the main generator. Output impedance is 600Ω .

Sweep Output

0 to +5V (nominal, open circuit) ramp. Output impedance is 600Ω . Sweep time is 100s to 100 μs .

VCG (FM) – Voltage Controlled Generator

Up to 1000:1 frequency change with external 0 to +5V signal.

Mode: Linear or logarithmic.

Slew Rate: 2% of range per μs .

VCG Linearity: 0.0005 Hz to 50 kHz $\pm 0.5\%$ of range.

Voltage Controlled Amplitude (AM)

0 to $\pm 5\text{V}$ gives 0 to 30V amplitude change. AC input allows 0 to 200% modulation (suppressed carrier).

AC Input Range: 5V minimum for 100%, 10V minimum for 200% AM.

Input Impedance: 4.99 to 10 k Ω , depending on gain control.

Input Bandwidth: 10 kHz.

Trigger Input

Trigger Signal: 1V p-p minimum.

Trigger Level: $\pm 5\text{V}$.

Input Impedance: 1.5 k Ω , 30 pF.

Maximum Repetition Rate: 25 MHz.

1.2.3 Frequency Precision

Dial Accuracy (For \sim , \wedge , \square and linear dial settings of 0.5 to 5)

$\pm 2\%$ of full scale for 0.0005 Hz to 5 MHz.

+ 15%, - 6% of full scale for 5 to 50 MHz.

1.2.4 Amplitude Precision

Amplitude Change With Frequency

Sine and square variations less than:

± 0.1 dB to 100 kHz;

± 0.2 dB to 1 MHz;

± 3 dB to 50 MHz.

Step Attenuator Accuracy

± 0.3 dB per 20 dB step to 100 kHz.

1.2.5 Waveform Characteristics

Sine Distortion (Test at 10V p-p normal sine wave)

Less than 0.5% for 10 Hz to 100 kHz.

All harmonics greater than:

30 dB down for 100 kHz to 5 MHz;

20 dB down for 5 to 50 MHz.

Triangle Linearity



Greater than 99% for 0.005 Hz to 100 kHz.

Square Wave Aberrations (Test at 10Vp-p)

Less than 5% of p-p voltage.

1.2.6 Pulse Generator

Pulses

Variable amplitude positive or complementary pulses , . Pulse amplitude, width and rise/fall times are independently adjustable and independent of frequency. TTL and TTL pulse widths are simultaneous with main pulse. AM and FM modulation. All pulses can drive 50 Ω terminations.

Operational Modes

Continuous, Triggered, Double Triggered, Gated and Continuous Sweep. (See Sweep/Function Generator.)

External Width: An external signal at the trigger input determines the output pulse width and frequency.

Pulse Period Range

Pulse period is selectable from 20 ns to 10,000s (50 MHz to 0.0001 Hz) with approximately 1% vernier.

Pulse Width

10 ns to 100 ms in 7 ranges. Maximum duty cycle is 70% for periods to 200 ns, decreasing to 50% for 20 ns periods. Control has nominal 50% duty cycle detent.

Transition Time

7 ns to 50 ms in 7 ranges, independently variable for leading and trailing edges.

Function Output

0 to $\pm 15\text{V}$ into open circuit and 0 to $\pm 7.5\text{V}$ into 50Ω . Voltage attenuation 0 to 80 dB: to 60 dB in 20 dB steps, plus 20 dB continuous vernier.

TTL and TTL Pulses

Transition times less than 4 ns into 50Ω termination.

1.2.7 General

Stability

Amplitude, dc offset and frequency in linear mode to 500 kHz.

Short Term: $\pm 0.05\%$ for 10 minutes.

Long Term: $\pm 0.25\%$ for 24 hours.

Environmental

Specifications apply at $25^{\circ}\text{C} \pm 5^{\circ}\text{C}$ after 30 minute warm-up.

Instrument will operate from 0°C to $+50^{\circ}\text{C}$.

Dimensions

36.2 cm (14¼ in.) wide; 13.3 cm (5¼ in.) high; 38.1 cm (15 in.) deep.

Weight

9.8 kg (21½ lb) net; 12.5 kg (27½ lb) shipping.

Power

108 to 132V or 216 to 250V; 50 to 400 Hz; 50 watts nominal.

SECTION 2

INITIAL PREPARATION

2.1 MECHANICAL PREPARATION

After unpacking the instrument, visually inspect all external parts for possible damage to connectors, surface areas, etc. If damage is discovered, file a claim with the carrier who transported the unit. The shipping container and packing material should be saved in case reshipment is required.

2.2 ELECTRICAL INSTALLATION

2.2.1 Power Connection

WARNING

To preclude injury or death due to shock, the third wire earth ground must be continuous to the facility power outlet. Before connecting to the facility power outlet, examine extension cords, autotransformers, etc., between the instrument and the facility power outlet for a continuous earth ground path. The earth ground path can be identified at the plug on the instrument power cord; of the three terminals, the earth ground terminal is the nonmatching shape, usually cylindrical.

CAUTION

To prevent damage to the instrument, check for proper match of line and instrument voltage and proper fuse type and rating.

NOTE

Unless otherwise specified at the time of purchase, this instrument was shipped from the factory with the power transformer connected for operation on a 108 to 126 Vac line supply and with a 0.5 amp slow blow fuse.

Conversion to other input voltages requires a change in rear panel fuse-holder voltage card position and fuse according to the following table and procedure.

Card Position	Input Vac	Fuse (Slow Blow, 3 AG)
100	90 to 105	0.5 amp
120	108 to 126	0.5 amp
220	198 to 231	0.25 amp
240	216 to 250	0.25 amp

1. Disconnect the power cord at the instrument, open fuse holder cover door and rotate FUSE PULL to left to remove the fuse (figure 2-1).

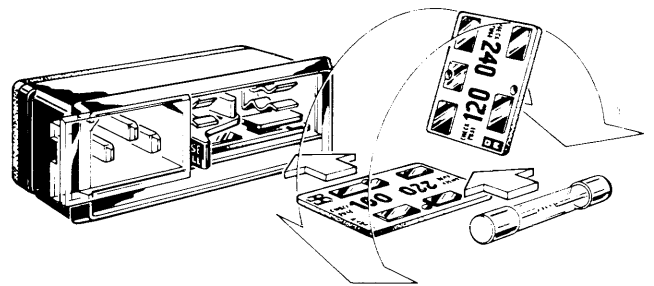

Figure 2-1. Fuse Holder on Rear of Instrument

2. Remove the small printed circuit board and select operating voltage by orienting the printed circuit board to position the desired voltage on the top left side. Push the board firmly into its module slot.
3. Rotate the FUSE PULL back into the normal position and insert the correct fuse into the fuse holder. Close the cover door.
4. Connect the ac line cord to the mating connector at the rear of the unit and the power source.

2.2.2 Signal Connections

Use RG58U 50Ω shielded cables equipped with female BNC connectors to distribute input and output signals when connecting this instrument to associated equipment.

2.3 ELECTRICAL ACCEPTANCE CHECK

This checkout procedure verifies the generator operation. If a malfunction is found, refer to the Warranty in the front of this manual. A 2 channel oscilloscope, a 50Ω load, a tee fitting and 50Ω coax cables are needed for this procedure (see figures 2-2 through 2-5).

Preset the pulse generator controls as follows:

Control	Position
FREQUENCY Dial	1
FREQ Range	X 1K
FREQ VERNIER	cw
GEN MODE	CONT
TRIG LEVEL	10 o'clock
LIN/LOG	LIN
DC OFFSET	OFF
VCA GAIN	ccw
WAVEFORM	~
OUTPUT ATTEN	0
OUTPUT ATTEN VERNIER	cw
NORM/INVERT	NORM
SWEEP MODE	CONT SWP
SWEEP STOP	cw
SWEEP TIME	10s 1s
SWEEP TIME VARIABLE	12 o'clock
PULSE WIDTH	⌊
PULSE WIDTH VARIABLE	cw
TRANSITION TIME	7 ns 50 ns
LEADING EDGE	cw
TRAILING EDGE	cw
POWER	ON

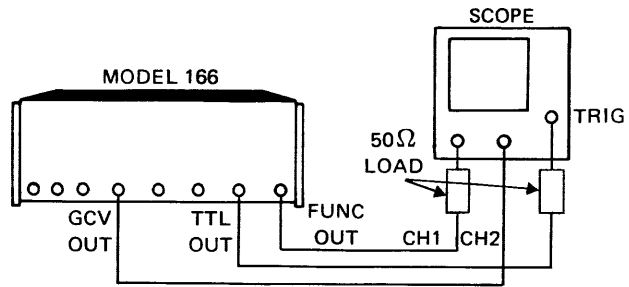

Figure 2-2. Initial Setup

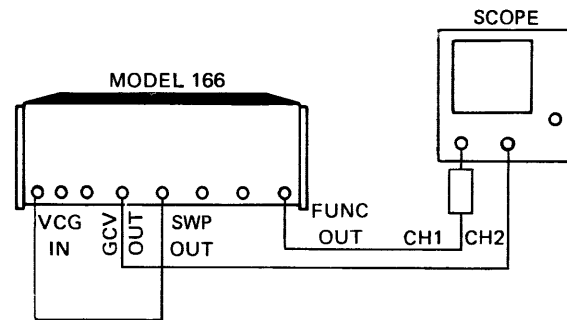

Figure 2-3. VCG Setup

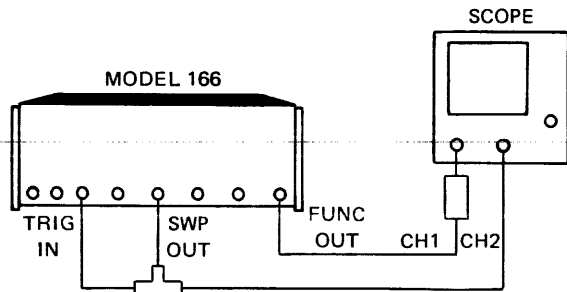

Figure 2-4. Trigger Setup

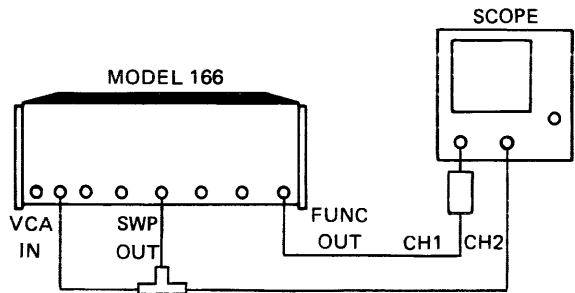





Figure 2-5. VCA Setup

Table 2-1. Initial Checkout

Step	Control	Position/Operation	Observation
1		Connect instrument as shown in figure 2-2 and sync scope to TTL output.	CH1: 1 kHz sine wave, 15V p-p. CH2: dc signal. Approximately 1V.
2	FREQ VERNIER	Rotate ccw, then cw.	CH1: A small change in frequency (1% of range).
3	FREQ Range	Check each position. Return to X 1.	CH1: Frequency increases from ccw to cw positions.
4	HOLD	Press and hold. Release.	Waveform stops and holds at a dc level. Waveform continuous when switch is released.
5	FREQ Range	X 1K.	
6	OUTPUT ATTEN VERNIER	Rotate ccw. Return to cw.	Amplitude of waveform decreases for ccw change.
7	OUTPUT ATTEN	Check each position. Return to 0.	Amplitude of waveform decreases in decade steps as attenuation increases.
8	OUTPUT ATTEN VERNIER	Rotate to 9 o'clock.	
9	DC OFFSET	Rotate cw thru -, 0 to +. Return to OFF.	Waveform moves to a negative offset, then to a positive offset, as the control is rotated cw. Waveform clipping may occur at - and + ends of control.
10	OUTPUT ATTEN VERNIER	Vernier cw.	
11	WAVEFORM	Check each position. Return to  .	Each waveform is present;  and  are both positive going 0V to +7.5V, but complementary to each other.



NOTE: For proper waveform output in steps 12 through 16, the pulse period must be several times longer than the pulse width and transition time. Change the FREQ range whenever necessary.

12	PULSE WIDTH	Rotate to each position. Return to 10 μ s 100 μ s.	Pulse width is <u>narrow at ccw positions and wider at cw positions.</u>
13	PULSE WIDTH VARIABLE	Rotate ccw. Return to cw.	Pulse width becomes narrow, returns to wide.
14	TRANSITION TIME	Rotate to each position. Return to 500 ns 5 ns.	Transition time decreases ccw and increases cw.
15	LEADING EDGE	Rotate ccw.	Waveform rise time increases, then returns to original time.

Initial Checkout (Continued)

Step	Control	Position/Operation	Observation
16	TRAILING EDGE	Rotate ccw.	Waveform fall time increases, then returns to original time.
17	FREQ Range	X 1K	
18	NORM/INVERT	INVERT, then NORM	Waveform changes from positive pulse to negative pulse.
19	WAVEFORM		
20	NORM/INVERT	INVERT, then NORM.	Waveform phase shifts 180°, from one switch position to the other.
21		Connect instrument as shown in figure 2-3.	
22	FREQUENCY Dial	Full cw. Sync the scope to CH1 (FUNC OUT).	CH1: Waveform is swept from a low frequency to a high frequency. CH2: 0 to 5V ramp for each burst of swept waveforms.
23	GEN MODE	SWEEP.	Waveform is swept from a low frequency to a high frequency.
24	SWEEP TIME	Check each position. Return to 100 ms I 10 ms.	As the switch is rotated cw, the sweep duration decreases. (Observe CH2 on fast times.)
25	LIN/LOG	LOG. Return to LIN.	CH1: Waveform has longer low frequency sweep in LOG mode. CH2: Logarithmic ramp in LOG mode.
26	SWEEP TIME VARIABLE	Rotate ccw. Return to cw.	Ccw increases sweep duration.
27	SWEEP MODE	SWP START.	CH1: Frequency approximately 50 Hz. CH2: 0 Vdc.
28	FREQUENCY Dial	Rotate from cw to ccw. Return to cw.	CH2: DC level increases from 0 to 5V, returns to 0V.
29	SWEEP MODE	SWP STOP.	CH2: Approximately 5V.
30	SWEEP STOP	Rotate ccw. Return to cw.	CH2: DC level decreases, returns to 5V.
31	SWEEP MODE	TRIG SWP.	CH1: Frequency approximately 50 Hz. CH2: 0V.
32	MAN TRIG	Press and release (try several times).	One burst of swept waveform, then returns to start frequency.

Initial Checkout (Continued)

Step	Control	Position/Operation	Observation
33	SWEEP MODE	SWP HOLD.	
34	MAN TRIG	Press and hold, then release.	Waveform sweeps up to high frequency and remains while switch is held, returns to start frequency when switch is released.
35	SWEEP MODE	CONT SWP	
36	FREQUENCY	1	
37		Connect instrument as shown in figure 2-4.	
38	GEN MODE	TRIG. (Trigger scope on CH2.) Adjust scope for several triggered cycles.	CH1: Each waveform is one complete cycle. CH2: 0 to 5V ramp.
39	GEN MODE	DBL TRIG.	Each waveform is two complete cycles.
40	GEN MODE	TRIG HAV.	Each waveform is one cycle starting and ending at -90° .
41	GEN MODE	GATED. Adjust scope for several bursts of waveforms.	Waveforms are in bursts of approximately 100 ms.
42	GEN MODE	GATED HAV.	Burst of waveforms start at -90° and end at -90° .
43	WAVEFORM		
44	GEN MODE	EXT WIDTH.	Pulse waveform.
45	TRIG LEVEL	Rotate slowly. Return to 10 o'clock.	Pulse varies in width. Returns to original width.
46		Connect instrument as shown in figure 2-5.	
47	GEN MODE	CONT.	
48	OUTPUT VERNIER	12 o'clock.	
49	WAVEFORM		CH1: Low to high amplitude bursts of waveforms.
50	VCA GAIN	Rotate from ccw to cw.	Amplitude modulation increases from 0 to maximum.

SECTION 3

OPERATION

3.1 CONTROLS AND CONNECTORS

The controls and connectors for the Model 166 are shown in figure 3-1. The listing below discusses each control and its function.

① **FREQUENCY/SWEEP START Dial** — The main frequency control. The setting on this dial multiplied by the frequency range (FREQ) setting is the basic output frequency of the generator. The dial sets the sweep start frequency when SWEEP mode (5) is selected. (The FREQ VERNIER and VCG IN also affect the generator frequency.) The outer scale has linear distribution; the inner has logarithmic (2). The dial index mark lights when power is on.

② **LIN/LOG Switch** — This switch selects a linear change in frequency or a logarithmic change in frequency when sweeping (20), frequency modulating (23) or using the frequency dial (1).

③ **FREQ Range Switch** — The 11 position outer switch selects the generator frequency range, which, when multiplied by the frequency dial setting (1), determines the basic output frequency of the generator.

VERNIER Control — The inner knob allows fine control over the output frequency. A complete turn of this vernier is equivalent to approximately one half of the smallest division on the main frequency dial (1). When in the full clockwise position (CAL), the settings on the main dial will be accurate.

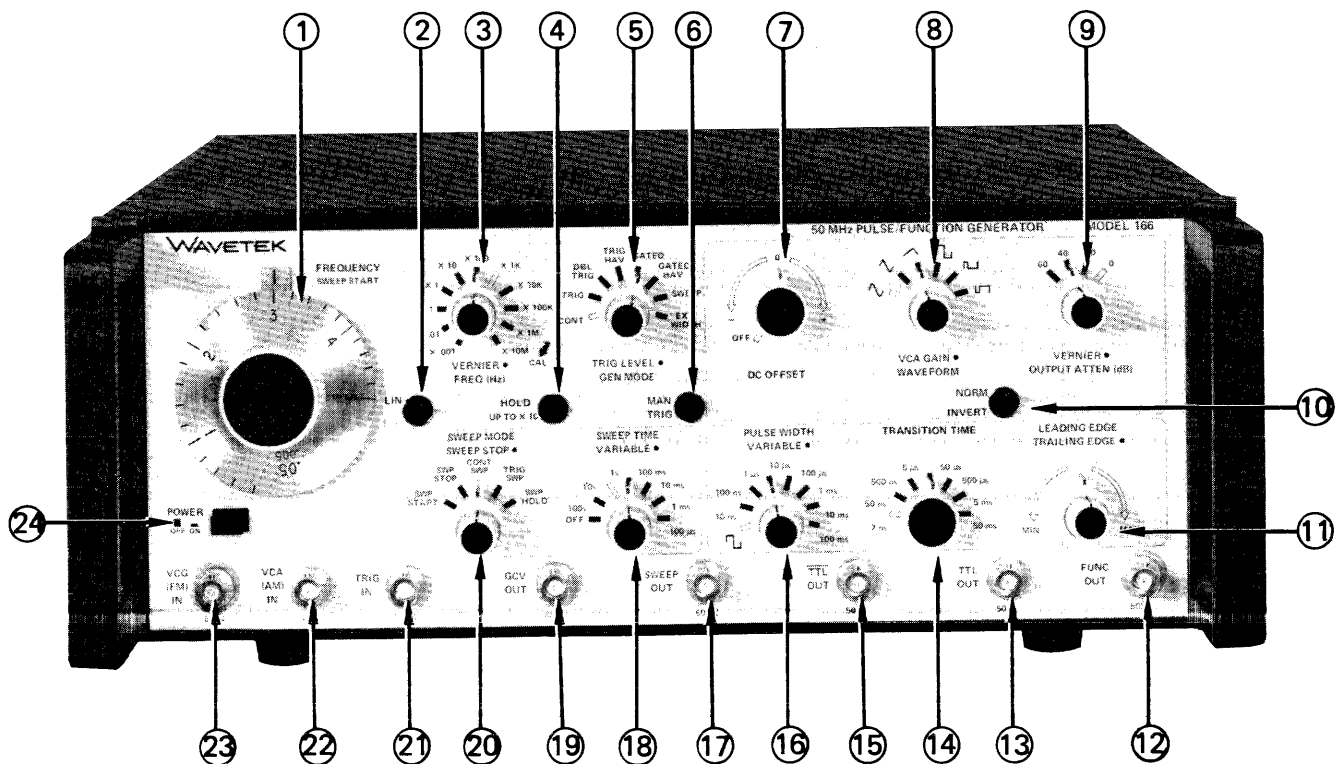

Figure 3-1. Controls and Connectors

4 **HOLD Switch** — This switch holds the output at its instantaneous voltage level. Operable in the X .001 through X 10 FREQ ranges (3) only.

5 **GEN MODE Switch** — The outer, 8 position switch selects the operating mode of the main generator as follows:

a. **CONT Mode** — The generator operates continuously as a standard Voltage Controlled Generator (VCG). Frequency output is determined by front panel control settings in conjunction with external control voltage at VCG IN (23).

b. **TRIG Mode** — The generator will give one complete cycle (starting at 0°) of output when the MAN TRIG (6) is pressed or for each cycle of signal applied to TRIG IN (21). A convenient trigger source is the SWEEP OUT signal (17), since the internal sweep operates independently of the main generator.

c. **DBL TRIG Mode** — As for TRIG mode, except two cycles are given.

d. **TRIG HAV Mode** — As for TRIG mode, except the waveform (\sim , \sim) starts and ends at -90° , rather than 0° ; this is a haverwave. For \square , \square and \square waveforms, this mode is identical to TRIG mode, except the delay between TRIG IN (21) and FUNC OUT (12) is increased.

e. **GATED Mode** — As for TRIG mode, except that the generator will continue to have output for the full time that the MAN TRIG switch (6) is held down or the gate signal at TRIG IN (21) exceeds the gating level set by the TRIG LEVEL control.

f. **GATED HAV Mode** — As for TRIG HAV mode, except that the generator will continue to have output for the full time that the MAN TRIG switch (6) is held down or the gate signal at TRIG IN (21) exceeds the gating level set by the TRIG LEVEL control (5).

g. **SWEEP Mode** — The generator operates in a sweep mode determined by the SWEEP MODE switch (20).

h. **EXT WIDTH Mode** — For \square , \square and \square waveforms only. The main generator is disabled and the output frequency and pulse width are dependent on the external signal input at the TRIG IN BNC (21) or the MAN TRIG switch pulse (6).

TTL OUT and FUNC OUT signals are at a dc level until triggered. Output, compared to the input, can be normal \square or complementary \square as set by the WAVEFORM switch (8), or positive (NORM) or negative (INVERT) as set by the NORM/INVERT switch (10).

TRIG LEVEL Control — The inner control is a continuously variable adjustment of the TRIG IN (21) circuitry. When full ccw, approximately a positive going signal of +5V or greater voltage is required for triggering (figure 3-2). In the full cw position, a positive going pulse of approximately -5V or more positive voltage is required for triggering. In the GATED mode, the generator will begin to run continuously at some position of the control cw past 12 o'clock. When using the MAN TRIG, this control must be ccw of the midpoint.

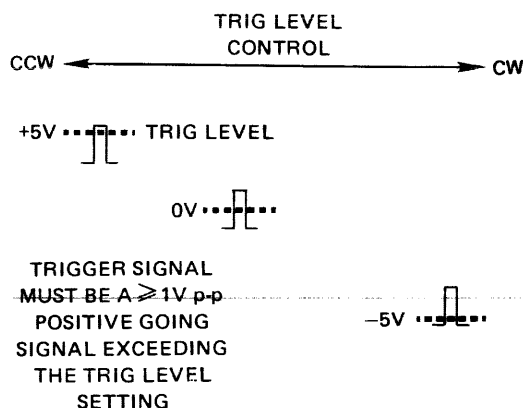







Figure 3-2. Minimum Trigger

6 **MAN TRIG Switch** — When in any of the trigger modes, pressing this switch furnishes the trigger. When in any of the gate modes, this switch furnishes the gate signal for the duration that it is pressed and held down. The TRIG LEVEL control (5) must be ccw from midpoint for proper MAN TRIG operation.



7 **DC OFFSET Control** — This knob adjusts the dc base line offset above (+) or below (-) signal ground to ± 10 Vdc into open circuit (± 5 Vdc into 50Ω load). Waveform plus offset is limited to ± 15 V open circuit (± 7.5 V into 50Ω load).



8 **WAVEFORM Selector** – The six position outer switch selects the waveform that appears at the FUNC OUT BNC (12). The waveforms are sine , triangle , ramp , square , positive going pulse  and positive going complementary pulse .

VCA GAIN Control – When amplitude modulating with a signal at the VCA (AM) IN BNC (22), the inner knob determines the level of modulation by attenuating the input signal.

9 **OUTPUT ATTEN (dB) Control** – The four position outer knob attenuates the FUNC OUT waveform and offset (12) from 0 dB (15Vp-p max into 50Ω LOAD) to –60 dB (15 mV p-p into 50Ω) in 20 dB steps. The inner VERNIER knob varies the attenuation over an additional 0 to approximately 20 dB. Maximum attenuation is 80 dB (1.5 mV p-p into 50Ω).



10 **NORM/INVERT Switch** – This switch inverts waveform output from FUNC OUT (12). Inversion is about the 0 volt axis of the non-offset waveform.





11 **LEADING EDGE Control** – For ,  and  waveforms only. The outer knob varies the leading edge transition time throughout the range indicated by the TRANSITION TIME switch (14). Transition time should not exceed the pulse width.

TRAILING EDGE Control – For ,  and  waveforms only. The inner knob varies the trailing edge transition time throughout the range indicated by the TRANSITION TIME switch (14). Transition time should not exceed the “off” time of the pulse period.









12 **FUNC OUT, 50Ω Connector** – This BNC connector is the selected waveform output of the main generator. Output level is 30V p-p maximum into an open circuit or 15V p-p maximum into a 50Ω load.

13 **TTL OUT Connector** – This BNC connector is a source of TTL level pulses at the main generator frequency. Pulse width, but neither amplitude nor transition time are controllable. Amplitude is fixed at an inactive level of 0.0 volts and an active level of approximately 2.4 volts when loaded with 50Ω. TTL pulse width is controllable regardless of the waveform selected.

14 **TRANSITION TIME Switch** – This seven position switch selects the range of pulse leading and trailing edge transition times. Actual in-range time is set by the LEADING EDGE control (11). Affects , 

and  waveforms at FUNC OUT (12). It has no effect on TTL and $\overline{\text{TTL}}$ outputs or on ,  and  waveforms. Transition time should not exceed the “off” time of the pulse period.

15 **$\overline{\text{TTL}}$ OUT Connector** – This BNC connector is a source of $\overline{\text{TTL}}$ level pulses at the main generator frequency. Pulse characteristics are the same as for TTL pulses (13) except amplitude is fixed at an inactive level of approximately 2.4 volts and an active level of 0 volts when loaded with 50Ω.

16 **PULSE WIDTH Switch** – The outer eight position switch selects the pulse width range. The  position ensures a 50% duty cycle pulse. The inner VARIABLE knob varies the pulse width throughout the range selected by the outer knob. This knob is inactive when the outer switch is in the  position. The PULSE WIDTH switch affects ,  and  output at FUNC OUT (12) and the TTL (13) and $\overline{\text{TTL}}$ (15) outputs. The ,  and  waveforms are not affected. Pulse width cannot exceed 70% of pulse period.

17 **SWEEP OUT, 600Ω Connector** – This BNC connector provides a fixed 0 to nominal +5 volts sawtooth waveform whose period is determined by the SWEEP TIME control (18); there is no output when SWEEP TIME is OFF. Output also depends on the SWEEP MODE control (20):

Position	SWP OUT
SWP START	0V
SWP STOP	Approximately +5V
CONT SWP	Sawtooth
TRIG SWP	0V until triggered, then sawtooth and return to 0V
SWP HOLD	0V until triggered, then ramp to +5V and hold for duration of trigger, then return to 0V

18 **SWEEP TIME Switch** – The seven position outer knob provides a sweep duration range. The inner VARIABLE knob selects the actual sweep time. An OFF position ensures that the sweep generator is off and has no effect on the frequency of the main generator.

19 **GCV Out Connector** — This BNC connector provides the Generator Control Voltage, a nominal 0 to +5 volts proportional to the main generator frequency.

20 **SWEEP MODE Switch** — The main generator frequency is controlled by the sweep generator when the GEN MODE switch (5) is in SWEEP position; otherwise, the two generators are independent. The outer five position switch selects the mode in which the internal sweep generator affects the main generator. The sweep start frequency is set by the FREQUENCY dial (1) and the sweep stop frequency is set by the inner SWEEP STOP knob (20). The sweep modes are:

- a. **SWP START Mode** — The main generator operates at the frequency set by the FREQUENCY dial (1) and in the range set by the FREQ switch (3). This mode is used to set the sweep start frequency.
- b. **SWP STOP Mode** — The main generator operates at the frequency set by the SWEEP STOP knob (20) and in the range set by the FREQ switch (3). This mode is used to set the sweep stop frequency.
- c. **CONT SWP Mode** — The main generator frequency is swept up from the sweep start frequency to the sweep stop frequency as preset in the SWP START mode and SWP STOP mode and in the time determined by the SWEEP TIME switch (18); the signal immediately drops to the start frequency and sweeps again.

21 **TRIG IN, 1.5 k Ω Connector** — This BNC connector is dc coupled with 1.5 k Ω , 30 pF input impedance. Trigger signals must be 1V p-p or greater but within the range of $\pm 5V$. The TRIG LEVEL control (5) adjusts the sensitivity of the generator to this input signal. Trigger signal width must be 25 ns or greater. Trigger frequency must be less than 25 MHz. The trigger signal can trigger the main generator and/or the sweep generator, depending on the mode of operation selected.

22 **VCA (AM) IN, 3 k Ω Connector** — This BNC connector has input impedance of 4.99 to 10 k Ω depending upon the VCA GAIN setting (8). With VCA GAIN fully cw, 0 to ± 5 volts gives a 0 to 30 volt amplitude change; 5 Vac gives 100% modulation; 10 Vac gives 200% modulation (suppressed carrier). Increased voltages are required when the VCA GAIN control is used. AM signal bandwidth is limited to 10 kHz.

23 **VCG (FM) IN, 6 k Ω Connector** — This BNC connector is the Voltage Controlled Generator signal input, a

signal that controls the main generator frequency. With 0 volts in, the main generator frequency is determined by the frequency range selected and the frequency dial setting. A positive VCG voltage will increase this frequency, and a negative voltage will decrease the frequency. Operation is limited by the FREQ range switch setting (3). A 5 volt excursion will vary the frequency up to 1000:1, linearly or logarithmically.

24 **POWER Switch** — Power is on when this pushbutton switch is in, and off when extended.

3.2 WAVEFORM TIMING

The relationship among waveforms for different modes is illustrated in figure 3-3.



3.3 OPERATING PROCEDURE

No preparation of the instrument is required beyond completion of the initial checkout given in paragraph 2.3. It is recommended that a one-half hour warm-up period be allowed for the associated equipment to reach a stabilized operating temperature, and for the Model 166 to attain stated accuracies. The operator should be familiar with the controls and connectors given in paragraph 3.1 and the waveform relationships given in figure 3-3.

There are almost unlimited ways to set up the generator and waveforms that may be obtained. The following sections describe basic configurations and how to set them up.

Notice the grouping of controls on the front panel:

- a. the waveform and amplitude group
- b. the pulse characteristics group
- c. the sweep group
- d. the frequency and operating mode group

Internally, the sweep group will be used only in sweep mode. In addition, the sweep generator can be used as an independent signal source with its own output. This is a convenient source of trigger and modulating signals for the main generator. The pulse group is used only for altered forms of the ,  and  waveforms.

The setup instructions given in the next paragraphs must necessarily be general. They are divided for five applications which can be combined as required:

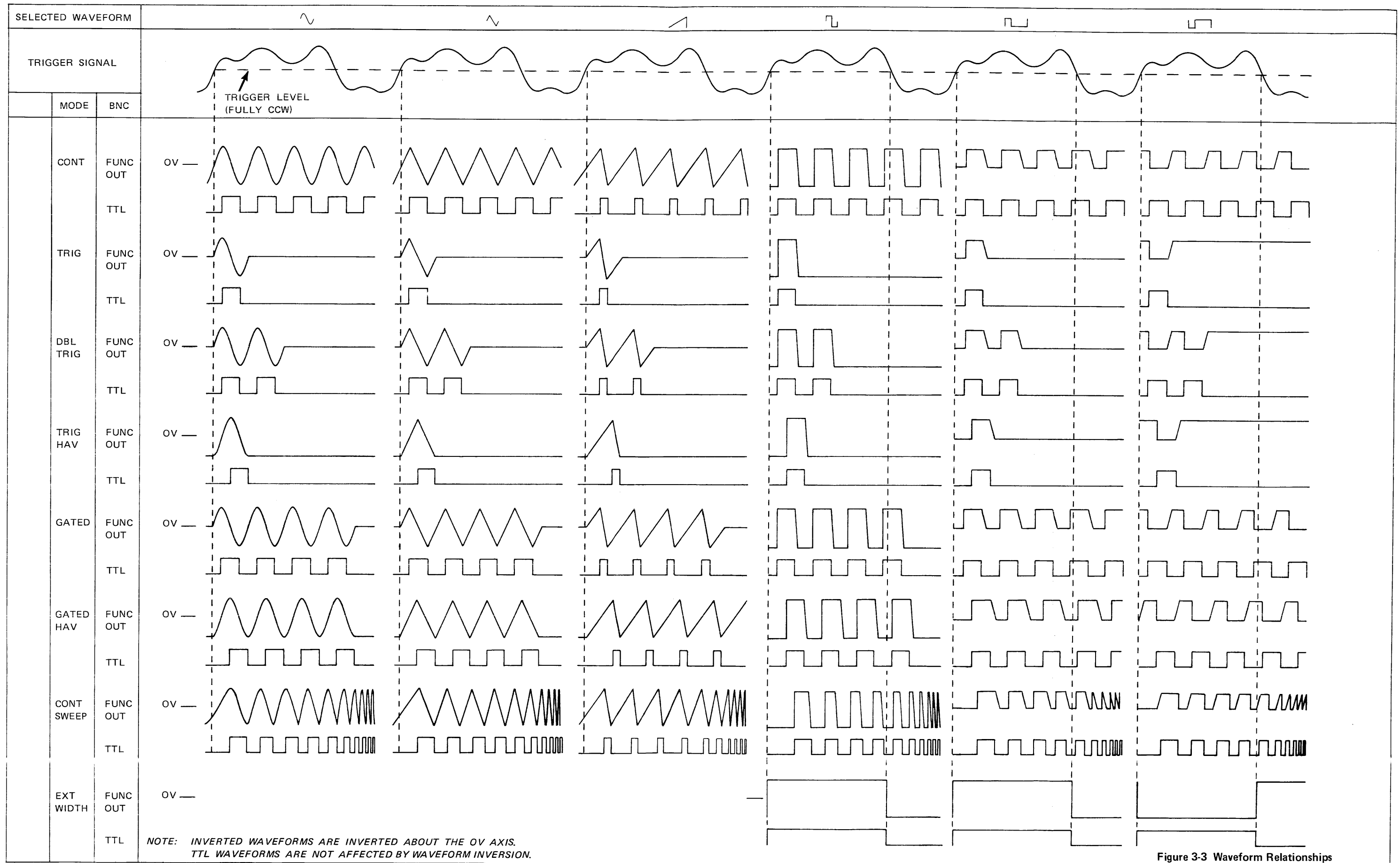

Figure 3-3 Waveform Relationships

- Continuous, triggered or gated operation
- Voltage controlled frequency (VCG) operation
- Sweep operation
- Pulse operation
- Voltage Controlled Amplitude (VCA) operation

3.3.1 Continuous, Triggered and Gated Operation

Operation in these modes is set up using standard waveforms. After getting results with a standard waveform, refer to paragraph 3.3.4 for pulse setup, if desired.

- For most accurate results, place the generator in continuous mode and monitor the setup of the controls with an oscilloscope. Connect FUNC OUT to the oscilloscope and sync to this signal. It is best to use an oscilloscope with greater than 250 MHz band width or a sampling oscilloscope. To view the high frequency performance with a real-time scope, use a 50Ω , 10:1 attenuator at the scope input to reduce the capacitive loading due to the scope.
- Set the frequency controls for the desired frequency.
- Select the waveform, attenuation and offset. This completes the setup for continuous mode.
- If one of the triggered or gated modes is desired, select the mode. If triggering is manual, rotate the TRIG LEVEL fully ccw. This completes the setup for manual triggering or gating.
- If an external trigger signal is to be used, connect a qualified trigger source (paragraph 3.1) to the TRIG IN BNC and to the oscilloscope trigger input. Set the scope to trigger on the external signal. Rotate the Model 166 TRIG LEVEL control fully ccw, then rotate cw until the desired triggering occurs.

3.3.2 Voltage Controlled Frequency (VCG) Operation

Set up the controls as given in paragraph 3.3.1 for continuous operation. The frequency selected will be the reference frequency. A voltage at the VCG BNC will cause the frequency to deviate from the reference frequency.

- For frequency control with positive dc inputs at VCG IN, set the dial for a lower limit from which frequency is to be increased.

- For frequency control with negative dc inputs at VCG IN, set the dial for an upper limit from which frequency is to be decreased.
- For modulation with an ac input at VCG IN, set the dial at the desired center frequency. Do not exceed the maximum dynamic range of the selected frequency range.

Figure 3-4 is a nomograph with examples of the frequency dial effect as a reference for VCG IN voltages. Example 1 shows that with 0V VCG input (2nd column), frequency (3rd column) is as determined by the frequency dial setting of 2 (1st column). Example 2 shows that with a positive VCG input, output frequency is increased. Example 3 shows that with a negative VCG input, output frequency is decreased. (Note that the Factor of 50Ω OUT Frequency column must be multiplied by the frequency range in order to give the actual 50Ω OUT frequency.) For full 1000:1 linear mode VCG sweep of the generator frequencies, set the FREQ VERNIER full ccw.

NOTE

The FREQ VERNIER must be rotated full ccw for 1000:1 linear or logarithmic range.

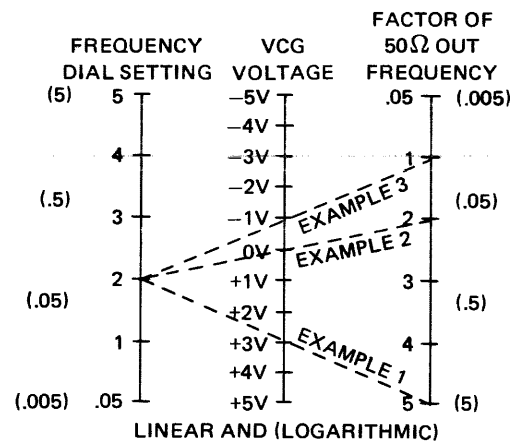







Figure 3-4. VCG Voltage-to-Frequency Nomograph

3.3.3 Sweep Operation

- Set SWEEP MODE to SWP START and adjust the FREQUENCY dial and FREQ range for start sweep frequency.
- Set SWEEP MODE to SWP STOP. Set SWEEP STOP control for the desired upper frequency.

- Set GEN MODE switch to SWEEP and SWEEP TIME switch to the approximate sweep duration desired.
- Set to CONT SWP mode and sync the oscilloscope with the SWEEP OUT signal. This completes the setup for continuous sweeping.
- If a triggered sweep mode is desired, select TRIG SWP or SWP HOLD, connect a qualified trigger source (paragraph 3.1) to the TRIG IN BNC and to the oscilloscope trigger input. Set the scope to trigger on the external signal. Rotate the Model 166 TRIG LEVEL control fully ccw, then rotate cw until the desired triggering occurs.

3.3.4 Pulse Operation

- Set up the controls as given in paragraph 3.3.1 for continuous operation. For pulse operation, select , , or  waveform, normal or inverted (figure 3-5).
- Set the pulse width as desired. Keep in mind that the pulse width cannot exceed approximately 70% of the "normal" waveform period. For wider pulses than those that can be normally obtained, set up the  pulse with the complement of the width that is desired, then switch to the complement pulse (). For example, a 95 ns pulse with a 125 ns repetition rate is desired. The complement of 95 ns is

$$125 - 95 = 30\text{ns}$$

Set up a 30 ns pulse with a 125 ns repetition rate and switch to the complement pulse as shown.

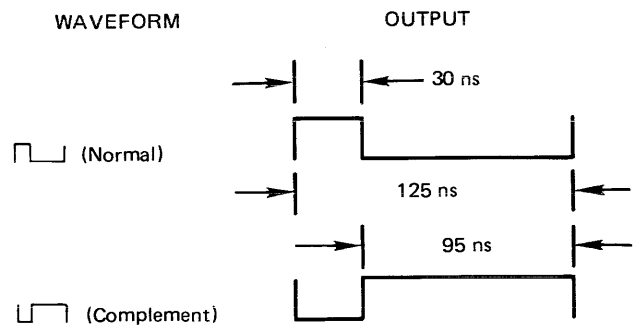

- Set the pulse leading and trailing edges. Pulse transition times are restricted to less than pulse width.

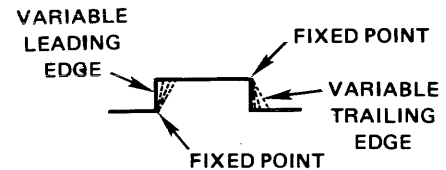

3.3.5 Voltage Controlled Amplitude (VCA) Operation

Set up the controls as given in paragraph 3.3.1 for continuous operation. The amplitude selected will be the reference amplitude. A voltage at the VCA BNC will cause the output amplitude to deviate from the reference amplitude. The VCA GAIN control can be used to attenuate the VCA input. For AM operation, 5V p-p gives 100% amplitude control or modulation, while 10V p-p gives 200% (suppressed carrier) modulation.











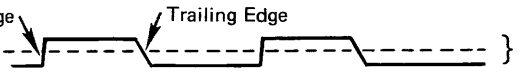

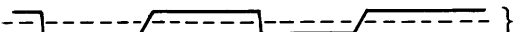

WAVEFORM	NORM/INVERT SWITCH	OUTPUT	REMARKS
	NORM		Amplitude is arbitrarily one.
	INVERT		Inversion rotates  about 0 axis.
	NORM		A 0 to Vp pulse.
	NORM		The complement of  .
	INVERT		Inversion rotates  about 0 axis.
	INVERT		Inversion rotates  about 0 axis.

Figure 3-5. Comparison of Available Pulses

4

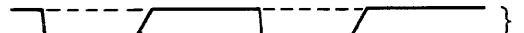
SECTION 4

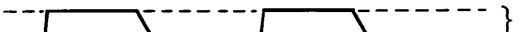
CIRCUIT DESCRIPTION

4.1 GENERAL

The circuits summarized in figure 4-1 are placed on two circuit boards in the generator. All circuits outside the dotted lines of the Sweep and Transition Time board (-0629) are on the Main board (-0628). The manual controls and connectors are mounted on the front panel. The power supply, which is not shown, is located on the rear panel and Main board.

4.2 BASIC WAVEFORM DEVELOPMENT

The heart of the generator (the bold path in figure 4-1) is a triangle and square wave generator. The triangle waves are developed by charging a capacitor with constant currents that are alternately reversed in polarity. The polarity reversal is caused by a flip-flop circuit, or hysteresis switch, that in turn produces the square waves. The flip-flop changes states, causing the constant current to change polarity, upon detecting amplitude limits of the triangle waveforms.

The VCG dial buffer sums the currents from the frequency dial, frequency vernier, VCG IN connector and the sweep circuit. The VCG dial buffer is an inverting amplifier whose output voltage can be applied directly to the GCV amplifier or through the log converter to the GCV amplifier. The output voltage of the GCV amplifier controls the positive and negative current sources. This voltage is also present at the GCV OUT connector. For all waveforms except the ramp the currents from the two current sources are equal and linearly (logarithmically in log mode) proportional to the voltage of the VCG dial buffer output in linear (log) operation. The diode gate, which is controlled by the hysteresis switch, is used to switch the positive or negative current to the integrating capacitor selected by the frequency multiplier. If the positive current is switched into the integrating capacitor, the voltage across the capacitor will rise linearly to generate the triangle rise transition. If the current is negative, the voltage across the integrating capacitor will fall linearly to produce the fall transition.

The triangle amplifier is a unity gain amplifier whose output is fed to the hysteresis switch. The hysteresis switch has two voltage limit points (approximately $\pm 1.25V$) at its input.

During the time the output voltage of the triangle amplifier is rising, the output voltage of the hysteresis switch is positive, but when the output voltage of the triangle reaches $+1.25V$, it triggers the hysteresis switch, causing the output to switch negative. Once the control voltage into the diode gate becomes negative, it will switch the positive current out and switch the negative current in to the integrating capacitor, so that the voltage across the capacitor will reverse, starting a linear decrease of the triangle wave. When the decreasing voltage reaches $-1.25V$, the output of the hysteresis switch will switch back to positive, reversing the process. This action generates the triangle waveform as shown in figure 4-2. Since the output of the hysteresis switch is a square wave, the result is simultaneous generation of a square wave and a triangle wave at the same frequency.

The output frequency is determined by the magnitude of the capacitor selected by the frequency multiplier and magnitude of the current sources. Since the current sources are linearly proportional to the control voltage of the VCG circuit, the output frequency will also be linearly proportional to the control voltage. The relations become logarithmic if the log mode of operation is chosen. The capacitance multiplier is used to sink a precise amount of the current supplied to the integrating capacitor on the low frequency ranges.

4.3 WAVE SHAPE AND AMPLIFICATION

The output of the hysteresis switch is shifted to MECL level and fed to the pulse width circuitry. The pulse width is determined by varying the RC time constant of an MECL one-shot. The output of the pulse width circuit feeds the TTL and TTL buffer and the rise/fall circuit. The TTL and TTL buffer circuit provides an approximate 0 to 2.4V output into 50 ohm load. The rise/fall circuit controls the transition time via selected RC networks, then returns the shaped square wave to the square wave clipper on the main board. When a square or pulse mode is selected, this clipper is activated to supply the signal to a pair of transistors which convert the single ended pulse to the differential input required by the multiplier.

The triangle wave from the triangle amplifier is coupled to another pair of transistors and the sine converter. This pair of transistors are turned on when triangle or ramp are selected

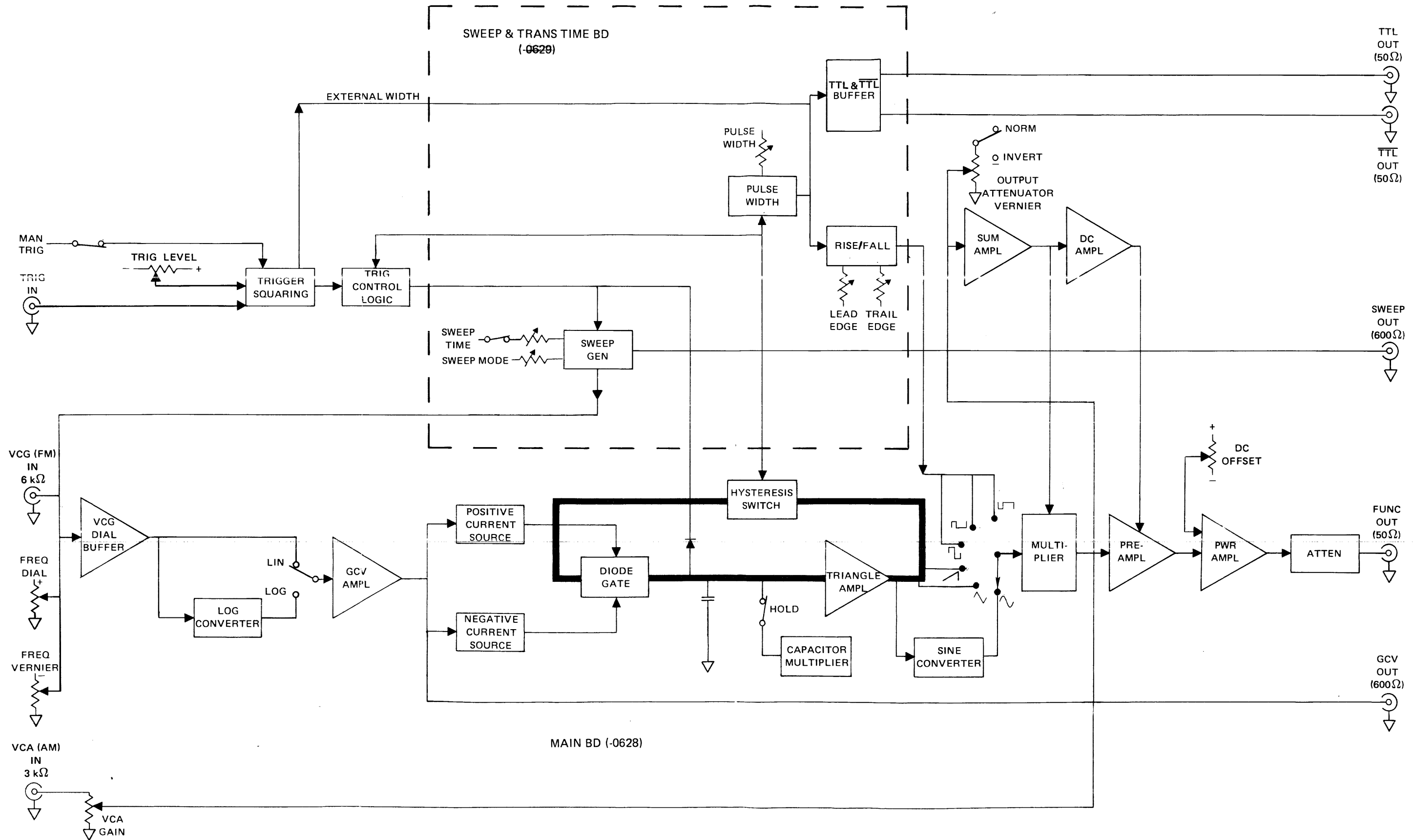

Figure 4-1. Generator Block Diagram

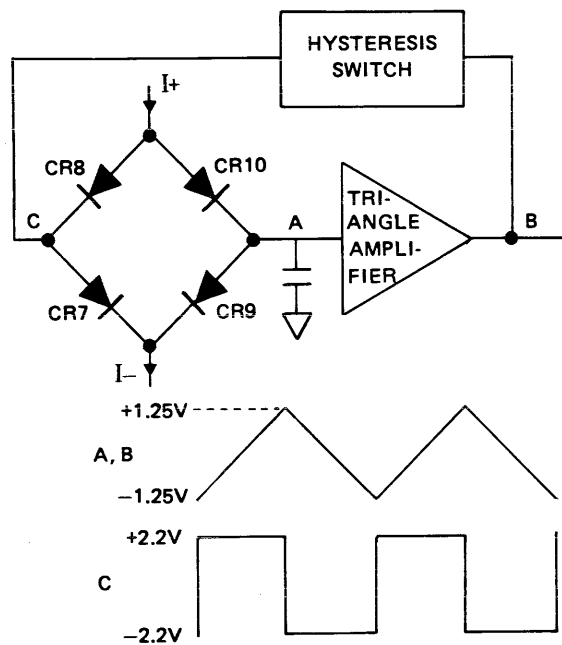

Figure 4-2. Basic Generator and Timing Diagram

and convert the single ended output to the differential input needed by the multiplier. The output of the sine converter is coupled through a similar pair of transistors before reaching the multiplier.

The amplitude vernier voltage and the VCA IN voltage are summed in the summing amplifier whose output is used to control the multipliers output amplitude. The phase of the output waveform is determined by the polarity of this voltage with the NORM/INVERT switch controlling the polarity of the dc from the amplitude vernier. In addition to being coupled to the modulating input of the multiplier, the output of the summing amplifier is coupled to another dc amplifier which keeps the pre-amplifier summing junction at the appropriate level when normal or complimentary pulse is selected.

A current mirror is used to convert the multiplier differential output to single ended output before it is applied to the inverting pre-amplifier. The output of the pre-amplifier provides an input to the summing junction of the output amplifier. The dc voltage from the DC OFFSET switch and potentiometer are also added in at the summing junction. The signal is again inverted and amplified before it is applied to the attenuator. The attenuator provides 60 dB of attenuation in three 20 dB steps. Maximum output at 0 dB is 15V into a 50 ohm load. Adjustment between steps is provided by the vernier.

4.4 TRIGGERED AND GATED MODES

In the triggered and gated modes, the forward biased trigger diode sinks the current from the positive current source, thereby preventing the integrating capacitor from charging and, therefore, the generator from oscillating. The trigger pulse resets a flip-flop which reverse biases the diode, so the capacitor begins to charge. The hysteresis switch transition, which occurs when the triangle wave reaches its negative peak, clocks the flip-flop back to the original state, which prevents the voltage at the integrating capacitor from rising above ground. In the haver modes, this voltage is held at the negative triangle peak. In gated mode, the falling edge of the trig in signal (the gating signal) releases the flip-flop to clock on next hysteresis switch transition occurring at a negative triangle peak. This forward biases the trigger diode so the voltage at the integrating capacitor may not rise above the set voltage (ground or the minus peak). The double trigger is accomplished by a series of flip-flops which "count" two negative triangle peak transitions of the hysteresis switch.

In EXT WIDTH mode, the signal to be shaped is applied to TRIG IN where it is squared in the trigger squaring circuit before being coupled to the rise/fall circuit, from which point it follows the normal square wave path. The generator must be set to square wave of pulse to obtain an output.

4.5 SWEEP GENERATOR MODES

The sweep generator is an independent generator with a 0 to +5V ramp out at the sweep out connector. It will drive up to 600 ohm impedance and can be used to externally trigger, VCG or VCA the main generator by connecting sweep out to the appropriate front panel connector.

The sweep generator can also be connected to the main generator internally by selecting SWEEP on the GEN MODE switch. The basic sweep generator consists of the current source, FET input amplifier, clamping circuit and hysteresis switch.

The current source charges a capacitor with a constant current which produces a voltage ramp across the capacitor. The ramp is buffered by the FET amplifier and applied to the hysteresis switch. When the ramp reaches the threshold voltage of the hysteresis switch, it changes state and discharges the capacitor very quickly through the discharge diode. The clamping circuit clamps the peaks of the ramp to precise levels which assume 1000:1 sweep control.

As the output of the sweep generator is internally connected to the input of the VCG dial buffer, it controls the frequency of the generator.

In SWP START mode, the sweep generator is held at its 0V peak so that the start frequency may be set with the combination of the frequency dial, frequency range and vernier. In SWP STOP mode, the sweep generator is held at its +5V peak, so that the portion of the voltage to reach the VCG dial buffer may be set in SWEEP STOP mode which determines the maximum frequency. In CONT SWP mode, the main generator is swept between the frequency limits set by sweep start and stop.

In TRIG SWP mode, the main generator oscillates at the start frequency until the trigger input triggers the sweep

generator. At the end of one ramp, the main generator returns to the start frequency and waits for the next trigger pulse.

In SWP HOLD mode, the main generator oscillates at the start frequency as long as the trigger input signal is below the trigger level threshold. As the threshold is crossed, the main generator is swept up to stop frequency, where it will remain until the trigger input falls below the threshold, at which time the main generator returns to the start frequency.

SECTION 5 CALIBRATION

5.1 FACTORY REPAIR

Wavetek maintains a factory repair department for those customers not possessing the necessary personnel or test equipment to maintain the instrument. If an instrument is returned to the factory for calibration or repair, a detailed description of the specific problem should be attached to minimize turnaround time.

5.2 REQUIRED TEST EQUIPMENT

DVM Millivolt dc measurement (0.1% accuracy)
 Differential Oscilloscope, Dual Channel 500 MHz bandwidth
 Distortion Analyzer 600 kHz
 Frequency Counter 50 MHz (0.1% accuracy)

5.3 CALIBRATION

Perform calibration according to table 5-1. If performing a partial calibration, check previous settings and adjustments for applicability. See figures 5-1, 5-2 and 5-3 for calibration point location.

1. Use 50Ω cable for all instrument connections.
2. Allow the instrument to warm up at least 30 minutes for the final calibration. Keep the instrument covers on to maintain heat. Remove covers only to make adjustments or measurements.

Table 5-1. Model 166 Calibration Chart



Step	Check	Tester	Calibration Point	Control Setting	Adjust	Desired Results	Remarks
1	Power Supplies	DVM or Differential Scope	-0628-TP1	FREQ: X 1K	-0645-R16	+12 Vdc ±50 mV	All measurements are referenced to ground.
2			-0628-TP2	FREQUENCY: 5		-12 Vdc ±100 mV	
3			-0628-TP3	FREQ VERNIER: CAL		+22 Vdc ±400 mV	
4			-0628-TP4	GEN MODE: CONT		-22 Vdc ±400 mV	
5			-0628-TP5	DC OFFSET: OFF	-0645-R24	+5.2 Vdc ±20 mV	
		WAVEFORM: 					
		OUTPUT ATTEN: 0					
		OUTPUT VERNIER:					
		12 o'clock					
		SWEEP MODE:					
		CONT SWP					
		SWEEP TIME: 10s 1s					
		PULSE WIDTH: 					
		TRANSITION TIME:					
		7 ns 50 ns					
		LEADING EDGE: Full ccw					
		TRAILING EDGE: Full ccw					
		LIN/LOG: LIN					
		NORM/INVERT: NORM					

Table 5-1. Model 166 Calibration Chart (Continued)

Step	Check	Tester	Calibration Point	Control Setting	Adjust	Desired Results	Remarks
6	Hysteresis Switch Balance	Scope	-0628-TP9		-0628-R150	□ Offset 0V ±100 mV	
7	□ Amplitude Zero		-0628-TP8	WAVEFORM: □	-0629-R31	□ Offset 0V ±50 mV	
8	∧ Amplitude Zero	DVM	-0628-TP6	GEN MODE: TRIG	-0628-R86	0 Vdc ±5 mV	
9	Multiplier Null	Scope	FUNC OUT	GEN MODE: CONT WAVEFORM: ∼ OUTPUT VERNIER: Full ccw	-0628-R330, R334	As near dc as possible	
10	Time Symmetry			WAVEFORM: □ Set output for 10V p-p	-0628-R46	Time symmetry within ±0.1%	See figure 5-4 for equipment setup. Set scope to 20 μs/div.
11	∼ Distortion			Distortion Analyzer	WAVEFORM: ∼	-0628-R103, R142	Minimum sine distortion
12	∼ Offset Shift	Scope			-0628-R241	No dc shift between normal and inverted output	Neglect the dc offset if any. Amplitude may be different between normal and inverted.
13	∧ Offset Shift			WAVEFORM: ∼	-0628-R210		
14	∼ Amplitude			WAVEFORM: Switch between ∼ and ∼	-0628 Select R212	∼ and ∼ peaks are within ±50 mV	
15	Preamp Zero	Differential Scope	-0628-TP7	WAVEFORM: ∼	-0628-R308	Positive and negative peak voltages are within 15 mV of each other.	
16	Output Amplifier Zero		FUNC OUT		-0628-R248	Positive and negative peak voltages are within 20 mV of each other.	

Table 5-1. Model 166 Calibration Chart (Continued)

Step	Check	Tester	Calibration Point	Control Setting	Adjust	Desired Results	Remarks
17	□ Positive Peak	Differential Scope	FUNC OUT	WAVEFORM: Switch between \sim and □	-0628-R198	Positive peaks of □ to \sim are within 50 mV	Verify or retrim R212.
18	□ Offset Shift	Scope		WAVEFORM: □	-0628-R203	No dc shift between normal and inverted output (or match to the negative \sim peak)	Amplitude can be different between normal and inverted output.
19	□ Normal/Inverted Amplitude			WAVEFORM: □ Switch between NORM and INVERT	-0628-R297	Zero levels are within 50 mV	Neglect the dc offset if any.
20	Output Amplitude			WAVEFORM: \sim OUTPUT VERNIER: Full cw	-0628-R254	Peak-to-peak voltages are 15V ±150 mV	
21	Trigger Baseline			WAVEFORM: \sim GEN MODE: GATED	-0628-R86	0 Vdc ±20 mV	
22	Haver Baseline			GEN MODE: TRIG HAV Connect SWEEP OUT to TRIG IN SWEEP TIME: 10 ms ms	-0628-R178	Baselines are at the same level of the negative peak \sim signal.	Set the trigger level control to obtain a burst of \sim signal.
23	VCG Null			GEN MODE: CONT FREQ: X 100K FREQUENCY: Full cw WAVEFORM: □ Set output to 10V p-p	-0628-R4	Less than 1% frequency shift while opening and shorting VCG IN to ground	
24	1000:1 Time Symmetry			LIN/LOG: LOG	-0628-R34, R59	Each half cycle □ is 1.2 ms and symmetry is < 1%	
25	Symmetry at 5 X 1 kHz			LIN/LOG: LIN FREQ: X 1K FREQUENCY: 5	-0628-R46	Time symmetry within 0.1%	
26	Symmetry at 0.5 X 1 MHz			FREQ: X 1M FREQUENCY: 0.5	-0628-R47	Time symmetry within 0.2%	
27	Symmetry at 0.5 X 10 MHz		FREQ: X 10M	-0628-R45 (trim)	Time symmetry < 1%	R45 must be installed for unit to oscillate on X 10M range. Verify or retrim.	

Table 5-1. Model 166 Calibration Chart (Continued)

Step	Check	Tester	Calibration Point	Control Setting	Adjust	Desired Results	Remarks																				
28	Frequency	Frequency Counter	TTL OUT	FREQ: X 1K FREQUENCY: 5	-0628- R13	5 kHz \pm 10 Hz	R13 affects frequency calibration in all frequency ranges.																				
29				FREQ: X 100	-0628- R18	500 Hz \pm 1 Hz																					
30				FREQ: X 10M	-0628- C24	50MHz \pm 500kHz	C22/23 may be added to lower frequency.																				
31				FREQ: X 1M	-0628- R15	5 MHz \pm 10 kHz	Trim C27 if R15 in stops.																				
32				FREQ: X 100K	-0628- R16	500 kHz \pm 1 kHz	Trim C25 if R16 in stops.																				
33				FREQ: X 10K	-0628- R17	50 kHz \pm 100 Hz	Trim R117 if R17 in stops.																				
34	Low Frequency Symmetry	Scope	FUNC OUT	FREQ: X 10 FREQUENCY: 0.5	-0628- R188	Time symmetry within 0.2%																					
35	Low Frequency	Counter	TTL OUT	FREQUENCY: 5	-0628- R182	50 Hz \pm 0.2 Hz (20 ms \pm 40 μ s)	Trim R181 if R182 in stops.																				
36	Logarithmic Frequency			FREQUENCY: 1 (Lin scale) FREQ: X 100K LIN/LOG: LOG	-0628- R50	1.99 kHz \pm 40 Hz	<table border="0"> <tr> <td>Cross Reference of Dial</td> <td></td> </tr> <tr> <td>Dial (lin)</td> <td>Dial (log)</td> </tr> <tr> <td>0</td> <td>.005</td> </tr> <tr> <td>1</td> <td>.020</td> </tr> <tr> <td>1.67</td> <td>.050</td> </tr> <tr> <td>2</td> <td>.079</td> </tr> <tr> <td>3</td> <td>.316</td> </tr> <tr> <td>3.33</td> <td>.500</td> </tr> <tr> <td>4</td> <td>1.26</td> </tr> <tr> <td>5</td> <td>5.00</td> </tr> </table>	Cross Reference of Dial		Dial (lin)	Dial (log)	0	.005	1	.020	1.67	.050	2	.079	3	.316	3.33	.500	4	1.26	5	5.00
Cross Reference of Dial																											
Dial (lin)	Dial (log)																										
0	.005																										
1	.020																										
1.67	.050																										
2	.079																										
3	.316																										
3.33	.500																										
4	1.26																										
5	5.00																										
37		FREQUENCY: 4	-0628- R20	125.6 kHz \pm 2.5 kHz																							
38		Repeat steps 24, 36 and 37 several times																									
39	High Frequency Waveform	Sampling Scope	FUNC OUT	WAVEFORM:  LIN/LOG: LIN FREQ: X 10M FREQUENCY: 0.6	-0628- R266, R285 R351	Minimum rise/fall time and aberration																					
40	Sweep Ramp Positive Peak	Scope	SWP OUT (no load)	SWEEP MODE: CONT SWP SWEEP TIME: 100 ms \parallel 10 ms	-0629- R110	Positive peak just starts to flatten																					
41	Sweep Ramp Zero Peak			SWEEP TIME VARIABLE: Full cw	-0629- R107	Zero peak just starts to round																					

Table 5-1. Model 166 Calibration Chart (Continued)

Step	Check	Tester	Calibration Point	Control Setting	Adjust	Desired Results	Remarks
42	Sweep Ramp Start	Scope	SWP OUT (no load)	SWEEP MODE: SWP START	-0629-R62	0V (0 to -5 mv)	
43	Final Calibration (optional)			Close covers and warm up for 1 hour; repeat step 11, then step 28.			Sine distortion calibration will affect all frequency calibration. Adjusting R13 will restore the frequency calibration.

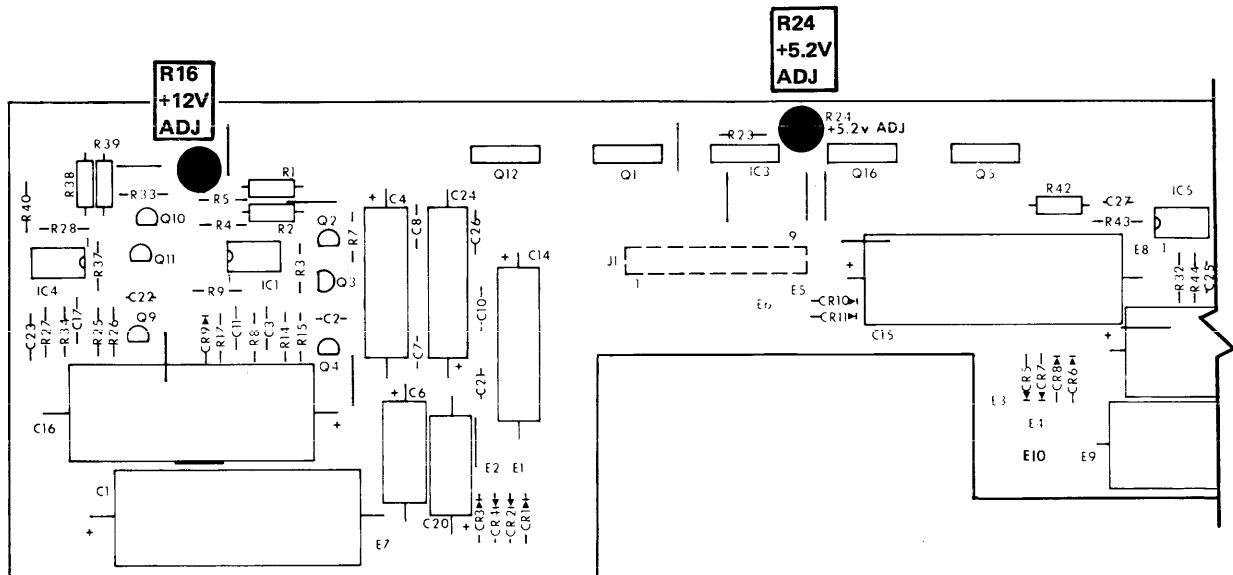

Figure 5-1. Power Supply (-0645) Calibration Points

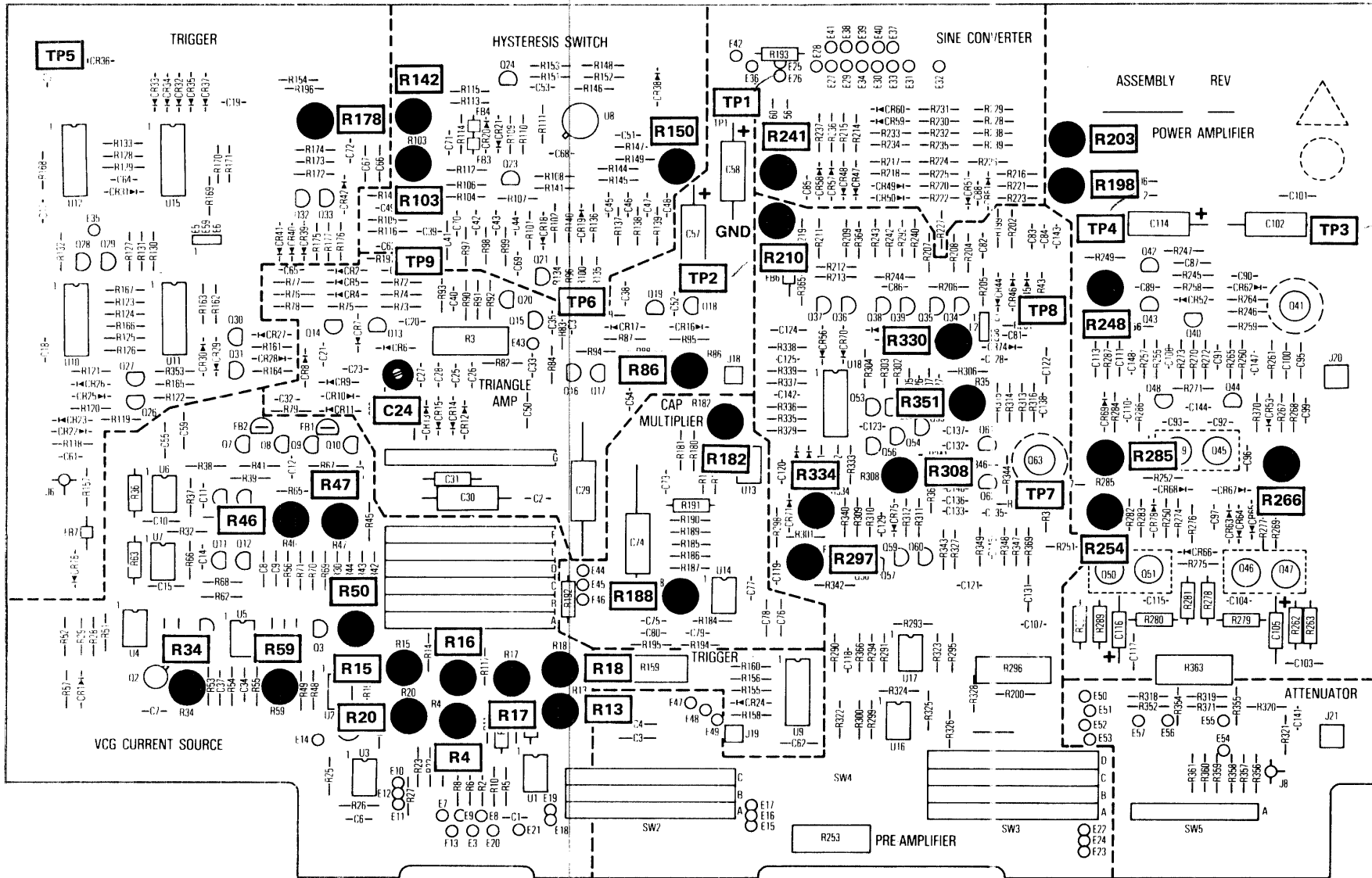

Figure 5-2. Main Board (-0628) Calibration Points

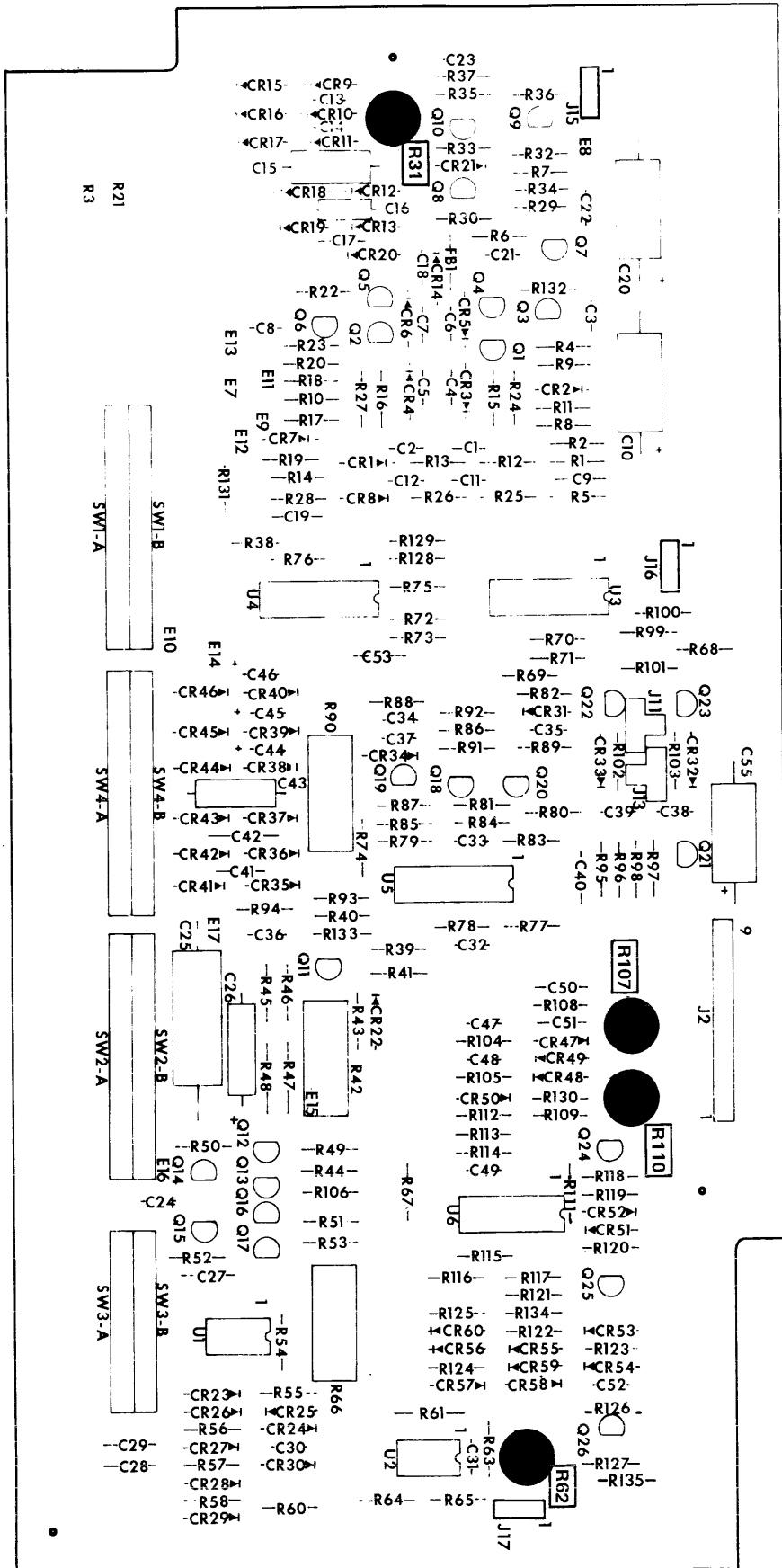
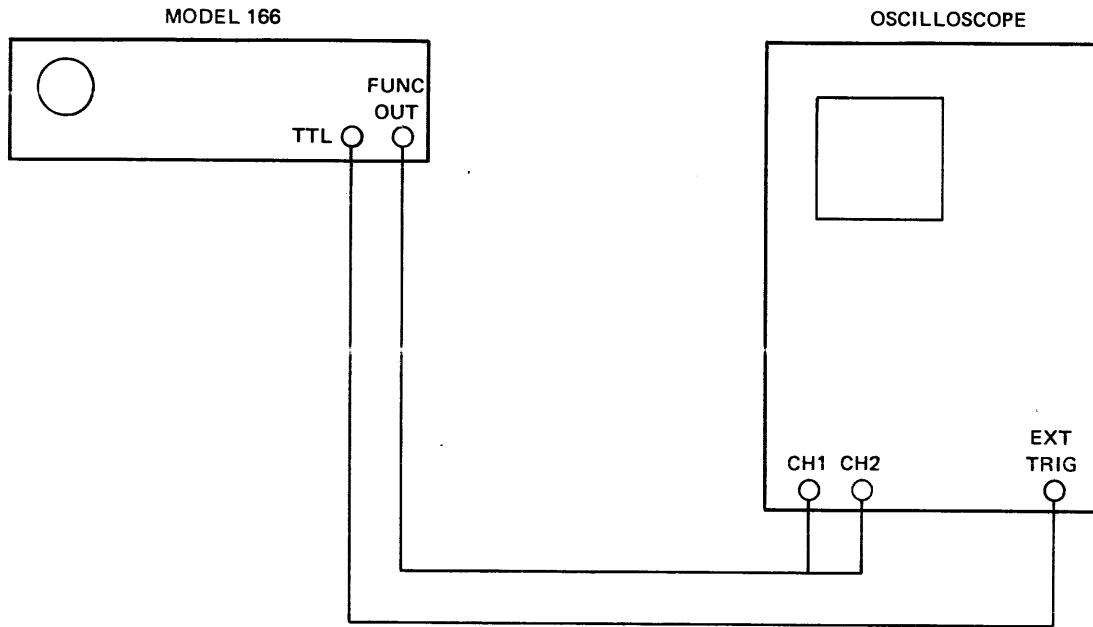

Figure 5-3 Sweep and Transition Time Board Calibration Points



NOTE

Set scope to normal external trigger. Use alternate or chop vertical mode. Set scope time so that one cycle just fills the screen. Using X 10 multiplication or delay time, expand time by 10. Now each cm represents 1% difference in symmetry.

Figure 5-4 Time Symmetry Calibration Setup

SECTION 6

TROUBLESHOOTING

6.1 INTRODUCTION

Familiarize yourself with the Model 166 by reviewing the operating procedures as well as the circuit descriptions. Successful fault isolation depends upon knowledge of the correct instrument operation. The physical arrangement of the instrument and component listings are given in Section 7.

Table 6-1 lists six basic problem areas and possible causes and corrections to problems in those areas.

PROBLEM AREAS

- Power Supply
- Output Waveform
- Time Symmetry
- Frequency Accuracy
- Generator Mode
- Sweep Circuit

Check points, expected values and component functions are given in tables 6-2 through 6-10, the troubleshooting guides.

TROUBLESHOOTING GUIDES

- Power Amplifier
- AM and Preamp
- Waveform Switching
- Hysteresis Switch
- Capacitance Multiplier
- VCG Current Source
- Transition Time
- Sweep Circuit

6.2 ACCESS

For access to the Power Supply board (-0645) and Main board (-0628), remove the top cover. For access to the Sweep and Transition Time board (-0629), remove the bottom cover.

6.3 TEST EQUIPMENT

Test equipment are listed in paragraph 5.2.

Table 6-1. Troubleshooting

Problem	Definition	Possible Cause/Correction
POWER SUPPLY PROBLEM		
1. Blown fuse	1. AC line voltage is not properly set. 2. Short circuit if fuse blows again after replacement. 3. Fuse blows again or voltage output at J1 is not correct.	Measure the ac line voltage and check for proper selection of line voltage in the unit. Refer to paragraph 2.2.1 for selection procedure. To locate source of short circuit, isolate the power supply by unplugging J1 on power supply board and J2 on sweep board. Turn on and check for correct voltage output at J1 on power supply board. Use an ohmmeter to detect possible short circuit between each power supply and ground: check at both input and output of the regulator to ground and also to chassis ground.

Table 6-1. Troubleshooting (Continued)

Problem	Definition	Possible Cause/Correction
2. Power regulator	<p>4. Short is not found in the regulator.</p> <p>5. If voltage output at J1 is normal, the short circuit is in main board or sweep board.</p> <p>1. Unplug and check voltage at J1 on power supply board. If voltage is not normal, proceed to the following steps.</p> <p>2. +5.2V is normal, but all $\pm 12V$, $\pm 24V$ supplies are abnormal.</p> <p>3. Both $-12V$ and $-22V$ are abnormal.</p> <p>4. Only $+22V$, $-22V$ or $+5.2V$ is abnormal.</p> <p>5. All regulator outputs are abnormal.</p>	<p>Check for short circuit of transformer, power switch or defective CR1 - CR8, CR10 or CR11.</p> <p>Check for short circuit between collector of Q1, Q5, Q12 or Q16 to chassis and also IC3.</p> <p>In most cases, short circuits in main board and sweep board do not cause blown fuses, unless the current limiting circuit in the power supply regulator has also failed. Q3, Q7, Q11 and Q15 in power supply board are the current limiting device.</p> <p>Problem is in the +12 volt regulator; check for defective Q1 - Q4, IC1, CR9 and the associated circuitry.</p> <p>Problem is in the $-12V$ regulator; check for defective Q9 - Q12, IC4 and the associated circuitry.</p> <p>Check the regulator in which the output voltage is abnormal.</p> <p>Check line voltage and proper selection of line voltage. Refer to paragraph 2.2.1 for line voltage selection.</p> <p>Check for defective transformer and loose wiring in the primary circuit.</p>
3. Power supply voltage below normal	<p>1. Unplug and check voltage at J1 on power supply board. If voltage is normal, the problem is in main circuit board or sweep board. Otherwise, refer to power regulator problem.</p> <p>2. Both $\pm 22V$ supplies below normal.</p>	<p>Overloading the +12V supply will cause all $\pm 12V$ and $\pm 22V$ supplies to be low. Overloading the $-12V$ supply will cause the $-22V$ supply to be low.</p> <p>Isolate the power supply to the sweep board by unplugging J2 on sweep board.</p> <p>Check for defective transistors Q45 - Q47 and Q49 - Q51 in power amplifier.</p>

OUTPUT WAVEFORM PROBLEM

1. No output waveform at FUNC OUT and TTL OUT	Main generator is not running.	Ensure power supply voltages are normal and switches and controls are set properly. Triangle amplifier, hysteresis switch or current source is malfunctioning. Refer to troubleshooting tables 6-5, 6-6, and 6-8.
2. No output waveform at FUNC OUT, but TTL OUT is normal		Problem in power amplifier, preamplifier or the AM circuit. Refer to troubleshooting tables 6-2 and 6-3.

Table 6-1. Troubleshooting (Continued)









Problem	Definition	Possible Cause/Correction
<p>✓ 3. No square waveform at FUNC OUT</p>	<p>1. TTL OUT is normal,  is seen at TP8 on main board.</p> <p>2. TTL OUT is normal,  is not seen at TP8 on main board.</p> <p>3.  output is normal, but no pulse width control.</p> <p>4. Also no TTL out. Check for $\pm 2.2V$  at emitter of Q22 to ensure the triangle generator loop is functioning. If not refer to tables 6-5, 6-6, and 6-8.</p> <p>Check the continuity of the square wave path to locate the defective components. Starting from main board pins <u>11</u> and <u>13</u> of <u>U11</u>, to pins <u>14</u> and <u>15</u> of <u>U11</u> through connector P16 to J16 on the sweep board. Then on the sweep board, pins 6 and 7 of U3, to pins 2 and 3 of U4 if  is selected, or pin 6 and 2 of U5 if  is selected.</p>	<p>Check for defective Q34, Q35, CR43 - CR46 and associated circuitry.</p> <p>Connector P15 is not plugged in.</p> <p>Transition time circuit is malfunctioning; check Q1 - Q6 and associated circuitry on sweep board.</p> <p>Transition time amplifier is malfunctioning; check Q7 - Q10 on sweep board.</p> <p>Check pulse width circuit, U5 and Q18 - Q20 on sweep board.</p>
<p>4. No sine waveform output</p>	<p>All other waveforms are normal.</p>	<p>Check sine amplifier Q38 and Q39 on main board.</p>
<p>5. Distorted sine waveform below 100 kHz.</p>	<p>1. Time symmetry of  is not $50\% \pm 0.5\%$.</p> <p>2. Nonlinear or distorted .</p> <p>3. Defective sine converter</p> <p>4. Defective X-Y multiplier circuit.</p>	<p>Square wave time symmetry is not calibrated correctly. Refer to TIME SYMMETRY PROBLEM.</p> <p>If the edge of the triangle is nonlinear at all frequency ranges, troubleshoot the VCG current source circuit (table 6-8).</p> <p>Check for defective Q15 and CR7 to CR11. If the peak of the triangle is distorted, check for defective range capacitors C22 to C31.</p> <p>Check for defective CR47 to CR61.</p> <p>Check for defective U18, Q52 and Q53.</p>

Table 6-1. Troubleshooting (Continued)

Problem	Definition	Possible Cause/Correction
6. Sine distortion out of specification at frequencies above 100 kHz.	Usually square wave will show up distorted or with slow rise/fall times.	Check preamplifier Q54 - Q63, or power amplifier Q42 - Q51. Check for defective capacitors in the circuit.
7. Transition time problem.		Check transition time circuit, Q1 - Q6, on sweep board.
8. No TTL and $\overline{\text{TTL}}$ output.		Check for defective U3, Q21 - Q23, on sweep board.
9. Excess of waveform rolloff at high frequency	<ol style="list-style-type: none"> 1. Excess rolloff shown at emitter of Q63. 2. Only sine waveform rolloff excess. 3. Otherwise. 	<p>Check for defective C126, C127, C133, C135, C145 and other frequency compensation components in this area, by connecting a capacitor in parallel with each capacitor.</p> <p>C86 is open or C88 has wrong value on main board.</p> <p>Check for defective capacitor in the power amplifier.</p>
10. Drooping on square wave ( not square)		Check for defective C126 or C127 on main board.
11. Nonlinear triangle waveform	<ol style="list-style-type: none"> 1. Occurs at only one frequency range. 2. Occurs at all frequencies and gets worse at bottom of frequency dial. 	<p>Check for defective timing capacitors C22 - C31 of the associated range.</p> <p>Check for defective Q15 and CR7 - CR11.</p>

TIME SYMMETRY PROBLEM

Waveform time symmetry is off and cannot be calibrated to within specifications	<ol style="list-style-type: none"> 1. All frequencies. 2. Frequency ranges X 10 and and below. 	<p>Usually due to the malfunctioning of the VCG current source circuit, U3 - U7, on main board. Check for leakage current at gate of Q2 - Q5, Q7, Q9 and Q11. check for excess source current at input of U3 - U7.</p> <p>Capacitance multiplier is malfunctioning. Check for defective U13 - U14 on main circuit board.</p>
---	--	--

FREQUENCY ACCURACY PROBLEM

Frequency out of specification	<ol style="list-style-type: none"> 1. Out of specification at all ranges. 2. Out of specification at X 10K range and up. 	<p>Mismatched dial and potentiometer (R1). Ensure that the number on the back of the dial matches the number on the potentiometer.</p> <p>Check for defective components in the VCG current source, U1 - U7 and Q2 - Q12 on main board.</p> <p>Check for defective components C35, C36, C39, C42 - C48, C53, C68, R97 - R99, R109, R116 and R137 - R139 on the main board.</p>
--------------------------------	--	--

Table 6-1. Troubleshooting (Continued)

Problem	Definition	Possible Cause/Correction
	3. Out of specification at X .001 Hz to X 10M.	Check for defective U13 - U14 and R185, R189 - R195 on main board.
	4. Frequency problem when LOG is selected.	Check for defective U2 and Q1 on main board.

GENERATOR MODE PROBLEM

1. Generator cannot be triggered or gated	1. Trigger sweep mode is ok.	Check for defective Q30 - Q33, U15, CR2 and the associated circuitry on main board. Troubleshoot using figure 6-1.
2. Triggered or gated mode ok, but no triggered haver-waveform	2. Trigger sweep mode is not operating.	Check for defective Q26, Q27 and the associated circuitry on main board.
2. Triggered or gated mode ok, but no triggered haver-waveform		Check for defective SW2-B, CR42 and R178 on main board.
3. No frequency sweep	1. No sweep signal at SWEEP OUT.	Sweep circuit is malfunctioning. Check for defective U1, U2, U6, Q11 - Q17 on sweep board.
3. No frequency sweep	2. SWEEP OUT is normal.	Check for loose wire connection between sweep board and main board. Check for defective SW2-A on main board or R66 on sweep board.

SWEEP CIRCUIT PROBLEM (Unless otherwise specified, components referred to are on the sweep board)

1. No signal at SWEEP OUT	1. Sweep signal is seen at pin 6 of U1.	Check for defective U2, CR28 and CR29.
1. No signal at SWEEP OUT	2. No sweep signal is seen at pin 6 of U1.	Refer to table 6-10.
2. Sweep signal runs continuously at TRIG SWP and SWP HOLD	Sweep mode control logic problem.	Check for defective CR53 - CR60 and SW3-B.
3. TRIG SWP and SWP HOLD are not operating	1. Manual trigger switch has no effect.	Check for defective MAN TRIG switch and U9 on main board.
3. TRIG SWP and SWP HOLD are not operating	2. Cannot be triggered by MAN TRIG or external signal at TRIG IN.	Check for defective Q26 and Q27 on main board and Q26 and CR55 - CR60 on sweep board.

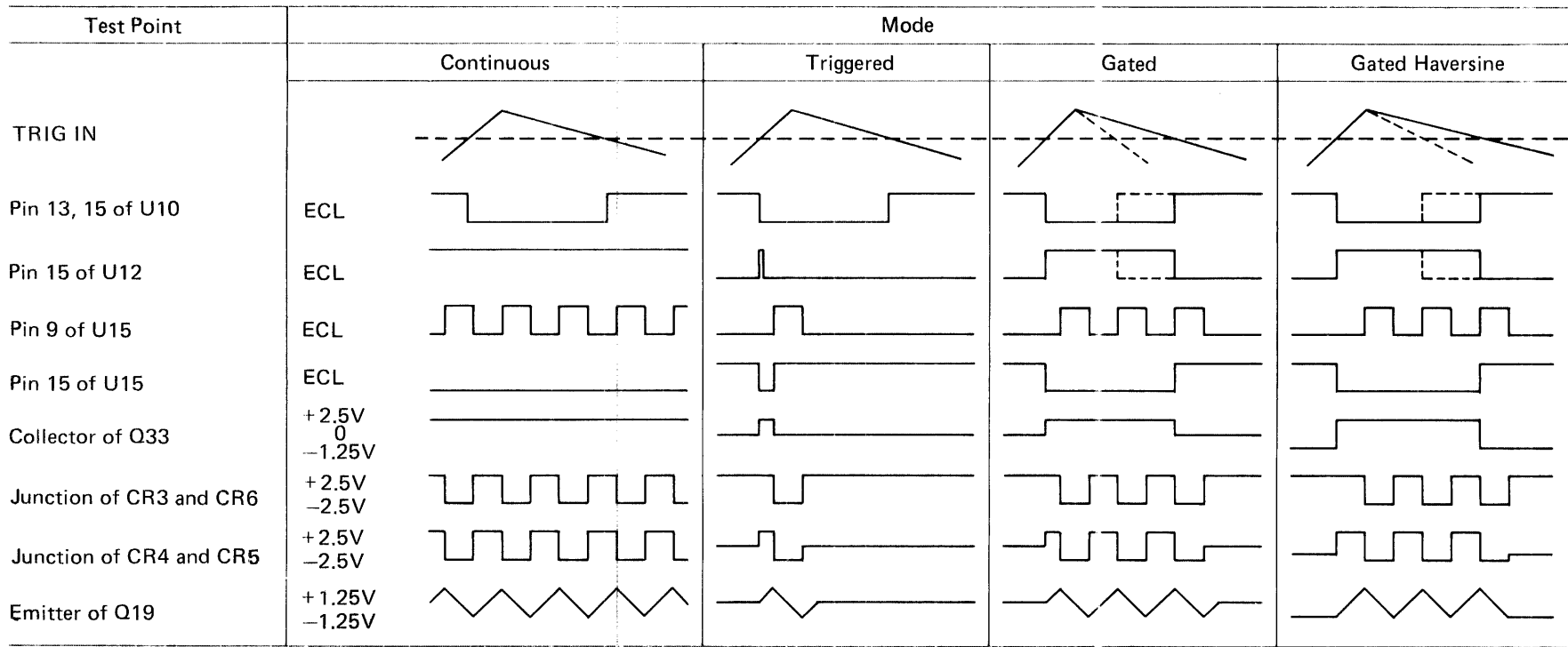

Figure 6-1. Generator Mode Timing Diagram

Table 6-2. Power Amplifier Troubleshooting Guide

Test Point	Observation
Junction R279 and R281.	Power amplifier output: 0 to 30 Vp-p signal.
Junction C92 and C93	Summing junction: 0 V with less than 2 Vac transient.
Emitter of Q63	Preamp output: 0 to 4 Vp-p signal, inverted from power amplifier output
Q40-Q43	Dc biasing circuit for power amplifier.
Base of Q44 and emitter of Q45	+19 Vdc.
Base of Q48 and emitter of Q49	-20 Vdc.
Q46 and Q47	Slow rise time if one of the transistors is open
Q50 and Q51	Slow fall time if one of the transistors is open
C92, C93, C96-C99, C109, C110, R266-R268 and R284-R286	These components affect the power amplifier frequency response the most.

Table 6-3. AM and Preamp Troubleshooting Guide

Test Point	Observation
Emitter of Q63	Preamp output: 0 – 3 Vp-p signal.
Q57-Q60	Dc bias circuit for the preamp.
Junction of C132 and C136	Summing junction, +1.8 Vdc typically.
Emitter of Q61	+5.5 Vdc.
Emitter of Q62	-5.5 Vdc.
C132-C137, C139-C140 and R351	Frequency compensation components.
U18	AM modulator.
Pins 6 and 12 of U18	AM current output. Out of phase with each other.
Q54-Q56	Current mirror circuit: sums current from pin 12 to pin 6.
C126 and C127	Excess drooping of square wave if defective.
Pins 2 and 3 of U18	Differential signal input: -4.5 Vdc level.
Pin 10 of U18	Amplitude control input: ± 200 mV.
U16 and U17	Amplitude control amplifiers.

Table 6-4. Waveform Switching Troubleshooting Guide







Test Point	Observation
Q38 and Q39	 amplifier and switch.
Q36 and Q37	 amplifier and switch.
Q34 and Q35	 amplifier and switch
Junction of CR43 and CR45	± 1.5 V  approximately
Junction of CR44 and CR46	± 0.5 V  .
Base of Q37	± 1.25 V  .
Base of Q38	± 0.4 V  approximately.
CR47-CR61	Sine converter diodes. Matched set.

Table 6-5. Triangle Amplifier Troubleshooting Guide

Test Point	Observation
Base of Q15	$\pm 1.25 \text{ V}$ $\wedge \vee$ (input).
Emitter of Q19	$\pm 1.25 \text{ V}$ $\wedge \vee$ (output).
Base of Q16	-9 Vdc.
R86	For amplifier offset calibration.
Q15 and Q17	Matched for V_{GS} . Q17 sets the bias current for Q15.
Q18 and Q19	Matched for V_{BE} . Excess offset between input and output of the amplifier may be due to defective or mismatched Q15 and Q17, or Q18 and Q19.

Table 6-6. Hysteresis Switch Troubleshooting Guide

Test Point	Observation
Junction of R101 and R136	$\pm 1.25 \text{ V}$ $\wedge \vee$.
Pin 1 of U8	Negative peak detector input.
Pin 4 of U8	Positive peak detector input.
Base of Q23 and Q24	+6 Vdc with 1.4 V \square .
Q23	Q23 on (collector + 2V) when $\wedge \vee$ going positive. Off (collector - 2.5V) when $\wedge \vee$ going negative.
Q24	On/off cycle inverts from Q23.
Emitter of Q22	$\pm 2.2 \text{ V}$ \square .
Emitter of Q21	2.5 Vp-p $\wedge \vee$.
Pin 3 and 9 of U8	-3 Vdc.
C70 and C42-C44	Negative peak compensation.
C45-C48	Positive peak compensation.
C71, C68, C70 and C48	Compensation for frequency above 10 MHz.

Table 6-7. Capacitance Multiplier Troubleshooting Guide

Test Point	Observation
Capacitance multiplier	Used only at frequency ranges X.001 to X10.
Junction of R195 and C80	+1.25V
Pin 6 of U13	-1.25V
Pin 6 of U14 (Dial at 5)	+7.5V
Pin 6 of U14 (Varies with Frequency)	-7.5V
	+3.75V
	-3.75V
	+3.75V
	-3.75V

Table 6-8. Current Source Troubleshooting Guide

Test Point	Observation
Pin 6 of U1	0 to -5.6 V. Varies with frequency.
Pin 6 of U3	0 to +5.6 V.
Gate of Q2	+12 V (Q2 is on) except when ramp waveform () is selected; then voltage is 0V (Q2 is off).
Pin 2 of U4	0 to 5.6 V. Varies with frequency.
Pins 2 and 3 of U6	+12 to 7.3 V.
Emitter of Q8	Approximately 4 V below emitter of Q6.
Pin 6 of U4	Voltage equal or greater than voltage at Pin 3 of U6.
Pin 6 of U6	Voltage equal or greater than voltage at S of Q5.
Pin 2 of U5	0 V.
Pin 2 and 3 of U7	-12 V to -6.4 V.
Emitter of Q10	Approximately 4 V above emitter of Q12.
U2 and Q1	Log converter. Used in log frequency only.
Emitter of Q24	+7.5 Vdc.
Base of Q13	± 1.2V pulse.
Pins 9 and 13 of U6	0V in CONT SWP.
Q26	Trigger sweep control input buffer amplifier.
CR53-CR60	Sweep mode control logic.

Table 6-9. Transition Time Troubleshooting Guide

Note: All components are on the sweep board

Test Point	Observation
Junctions of C1 and C2, C11 and C12	Square wave (ECL level) input to the transition time generator.
Q1 and Q4	Leading edge current switch.
Q2 and Q5	Trailing edge current switch.
CR3-CR6	Peak level clamp.
Q7-Q10	Unity gain amplifier. Output (emitter of Q9) is ± 1.2 V pulse.

Table 6-10. Sweep Circuit Troubleshooting Guide

Note: Unless otherwise noted, the sweep generator is set to CONT SWP and SWEEP TIME to 10 ms. All components are on the sweep board.

Test Point	Observation
Base of Q11	+6 Vdc.
Emitter of Q14	+6 Vdc.
Pins 3 and 6 of U1	-0.2 to +5.5 V ramp.
Pin 3 of U2	0 to +5 V ramp.
Q12 and Q13	Q12 is off and Q13 is on during ramp up time. Q12 is on and Q13 is off when ramp resets.
Q15	Reset current is discharged through the collector-base junction of Q15.
Q16 and Q17	In TRIG SWP mode, Q16 and Q17 hold the quiescent voltage of the ramp at pin 3 of U1 to -200 mV, which ensures CR29 is reverse biased and output at U2 is 0V.
P 2 of U6	0 V peak detector input.
Pin 6 of U6	+5V peak detector input.

SECTION 7

PARTS AND SCHEMATICS

7.1 DRAWINGS

The following assembly drawings, parts lists and schematics are in the arrangement shown below.

7.2 ORDERING PARTS

When ordering spare parts, please specify part number, circuit reference, board, serial number of unit and the function performed.

Drawing	Drawing No.
Instrument Schematic	0004-00-0128
Chassis Assembly	0102-00-0649
Chassis Parts List	1101-00-0649
Main Board Schematic	0103-00-0628
Main Board Assembly	0101-00-0628
Main Board Parts List	1100-00-0628
Main Board Switch Assemblies	1202-00-0041
Shield Board Assembly	0101-00-0684
Shield Board Parts List	1100-00-0684

7.3 ADDENDA

Under Wavetek's product improvement program, the latest electronic designs and circuits are incorporated into each Wavetek instrument as quickly as development and testing permit. Because of the time needed to compose and print instruction manuals, it is not always possible to include the most recent changes in the initial printing. Whenever this occurs, addendum pages are prepared to summarize the changes made and are inserted immediately inside the cover.

Drawing	Drawing No.
Sweep and Transit Time Board Schematic	0103-00-0629
Sweep and Transit Time Board Assembly	0101-00-0629
Sweep and Transit Time Board Parts List	1100-00-0629
Sweep and Transit Time Board Switch Assemblies	1202-00-0042
Power Supply Schematic	0103-00-0645
Power Supply Assembly	0101-00-0645
Power Supply Parts List	1100-00-0645
Rear Panel Assembly	0102-00-0648
Rear Panel Parts List	1206-00-0648

THIS DOCUMENT CONTAINS PROPRIETARY INFORMATION AND DESIGN RIGHTS BELONGING TO WAVETEK AND MAY NOT BE REPRODUCED FOR ANY REASON EXCEPT CALIBRATION, OPERATION, AND MAINTENANCE WITHOUT WRITTEN AUTHORIZATION.

REV	ECN	BY	DATE	APP
-----	-----	----	------	-----

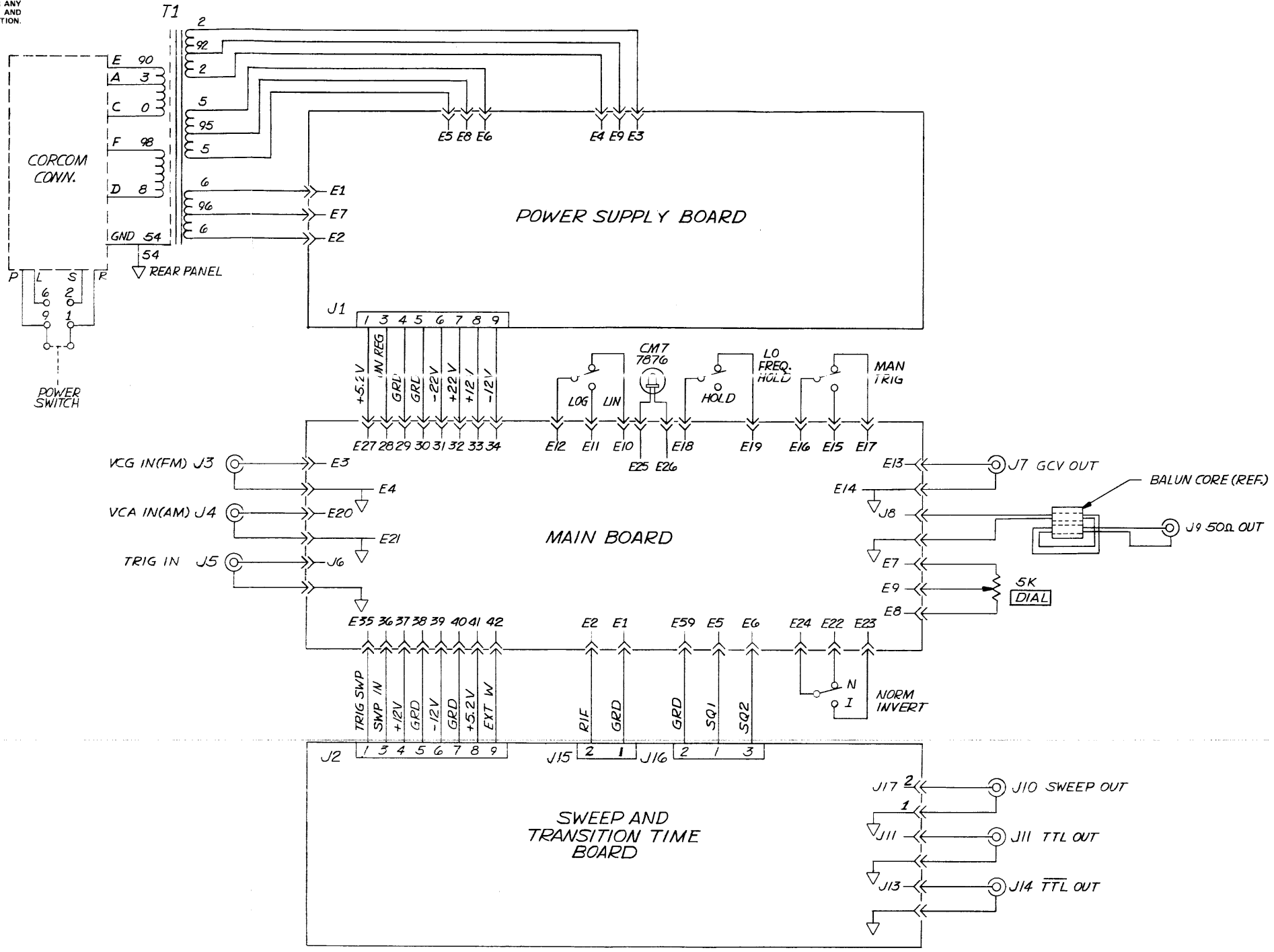

NOTE: UNLESS OTHERWISE SPECIFIED

REMOVE ALL BURRS AND BREAK SHARP EDGES	DRAWN D. COOPER	DATE 3-30-78	WAVETEK SAN DIEGO • CALIFORNIA	
MATERIAL	PROJ ENGR <i>Russell</i>	DATE <i>4/2/78</i>	TITLE SCHEMATIC INSTRUMENT	
FINISH WAVETEK PROCESS	TOLERANCE UNLESS OTHERWISE SPECIFIED XXX - .010 ANGLES - 1 XX - .030		MODEL NO. 166	DWG NO. 0004-00-0128
SCALE	DO NOT SCALE DWG		REV A	CODE IDENT 23338
			SHEET 1 OF 1	

THIS DOCUMENT CONTAINS PROPRIETARY INFORMATION AND DESIGN RIGHTS BELONGING TO WAVETEK AND MAY NOT BE REPRODUCED FOR ANY REASON EXCEPT CALIBRATION, OPERATION, AND MAINTENANCE WITHOUT WRITTEN AUTHORIZATION.

REV	ECN	BY	DATE	APP
B	ECN 1790	RO	5-16-78	K
C	ECN 1879	JH	2-21-78	

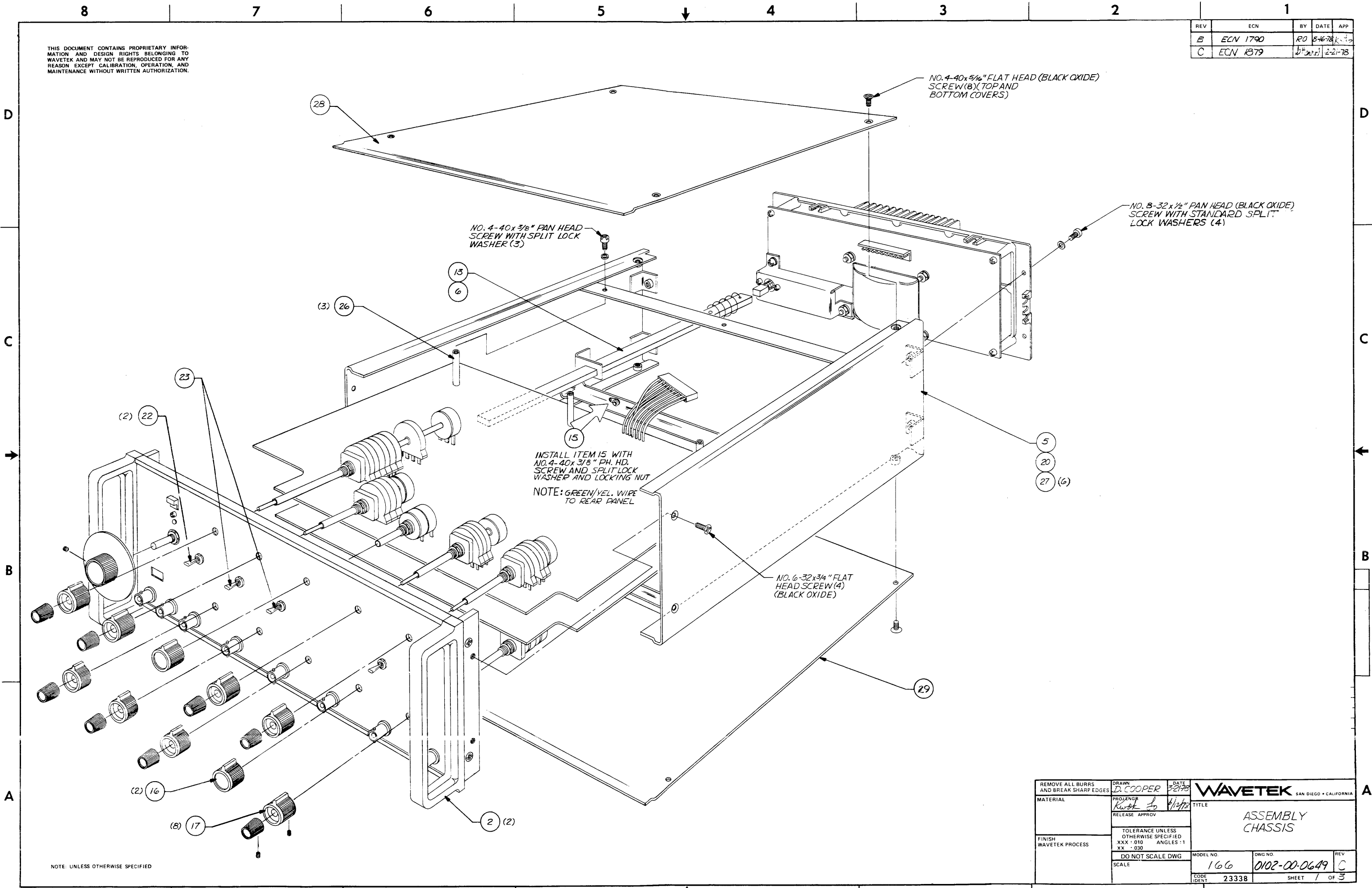

INSTALL ITEM 15 WITH NO. 4-40x3/8\" PH. HD. SCREW AND SPLIT LOCK WASHER AND LOCKING NUT
NOTE: GREEN/YEL. WIRE TO REAR PANEL

NOTE: UNLESS OTHERWISE SPECIFIED

REMOVE ALL BURRS AND BREAK SHARP EDGES	DRAWN D. COOPER	DATE 5-21-78	WAVETEK SAN DIEGO • CALIFORNIA	
MATERIAL	PROJ ENGR Kw	DATE 5/19/78	TITLE ASSEMBLY CHASSIS	
FINISH WAVETEK PROCESS	RELEASE APPROV	TOLERANCE UNLESS OTHERWISE SPECIFIED XXX ± .010 ANGLES : 1 XX ± .030	MODEL NO. 166	DWG NO. 0102-00-0649
	DO NOT SCALE DWG	SCALE	REV C	CODE IDENT 23338
			SHEET 1 OF 3	

8

7

6

5

↓

4

3

2

1

REV	ECN	BY	DATE	APP
-----	-----	----	------	-----

THIS DOCUMENT CONTAINS PROPRIETARY INFORMATION AND DESIGN RIGHTS BELONGING TO WAVETEK AND MAY NOT BE REPRODUCED FOR ANY REASON EXCEPT CALIBRATION, OPERATION, AND MAINTENANCE WITHOUT WRITTEN AUTHORIZATION.

D

D

C

C

B

B

A

A

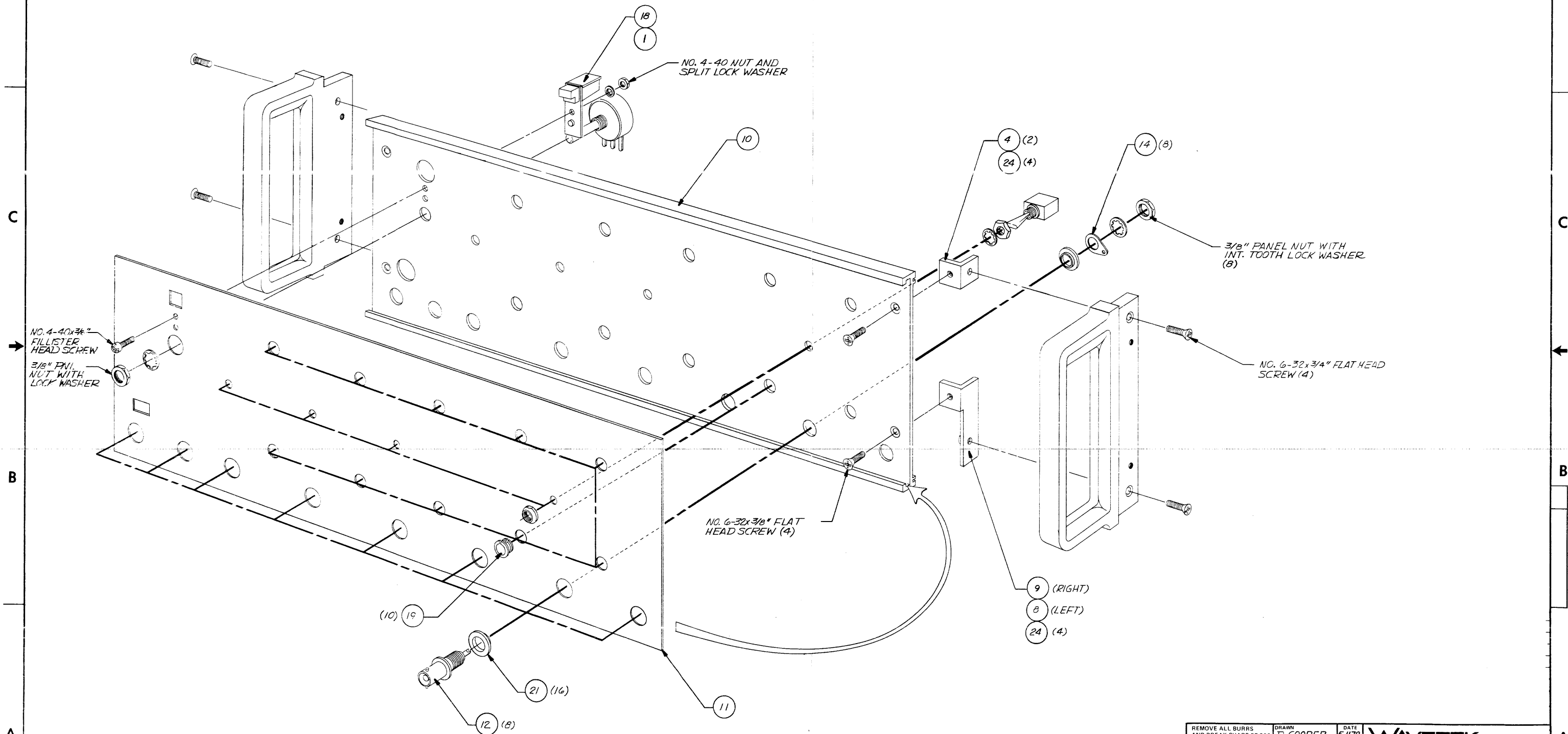

NOTE: UNLESS OTHERWISE SPECIFIED

REMOVE ALL BURRS AND BREAK SHARP EDGES	DRAWN <i>D. COOPER</i>	DATE 5/1/78	WAVETEK SAN DIEGO • CALIFORNIA	
MATERIAL	PROJENGR <i>R. W. ...</i>	DATE 6/1/78	TITLE ASSEMBLY CHASSIS	
FINISH WAVETEK PROCESS	TOLERANCE UNLESS OTHERWISE SPECIFIED XXX ± .010 ANGLES .1° XX ± .030		MODEL NO 166	DWG NO 0102-00-0649
DO NOT SCALE DWG		SCALE	REV C	CODE IDENT 23338
			SHEET 2 OF 3	

8

7

6

5

↑

4

3

2

1

THIS DOCUMENT CONTAINS PROPRIETARY INFORMATION AND DESIGN RIGHTS BELONGING TO WAVETEK AND MAY NOT BE REPRODUCED FOR ANY REASON EXCEPT CALIBRATION, OPERATION, AND MAINTENANCE WITHOUT WRITTEN AUTHORIZATION.

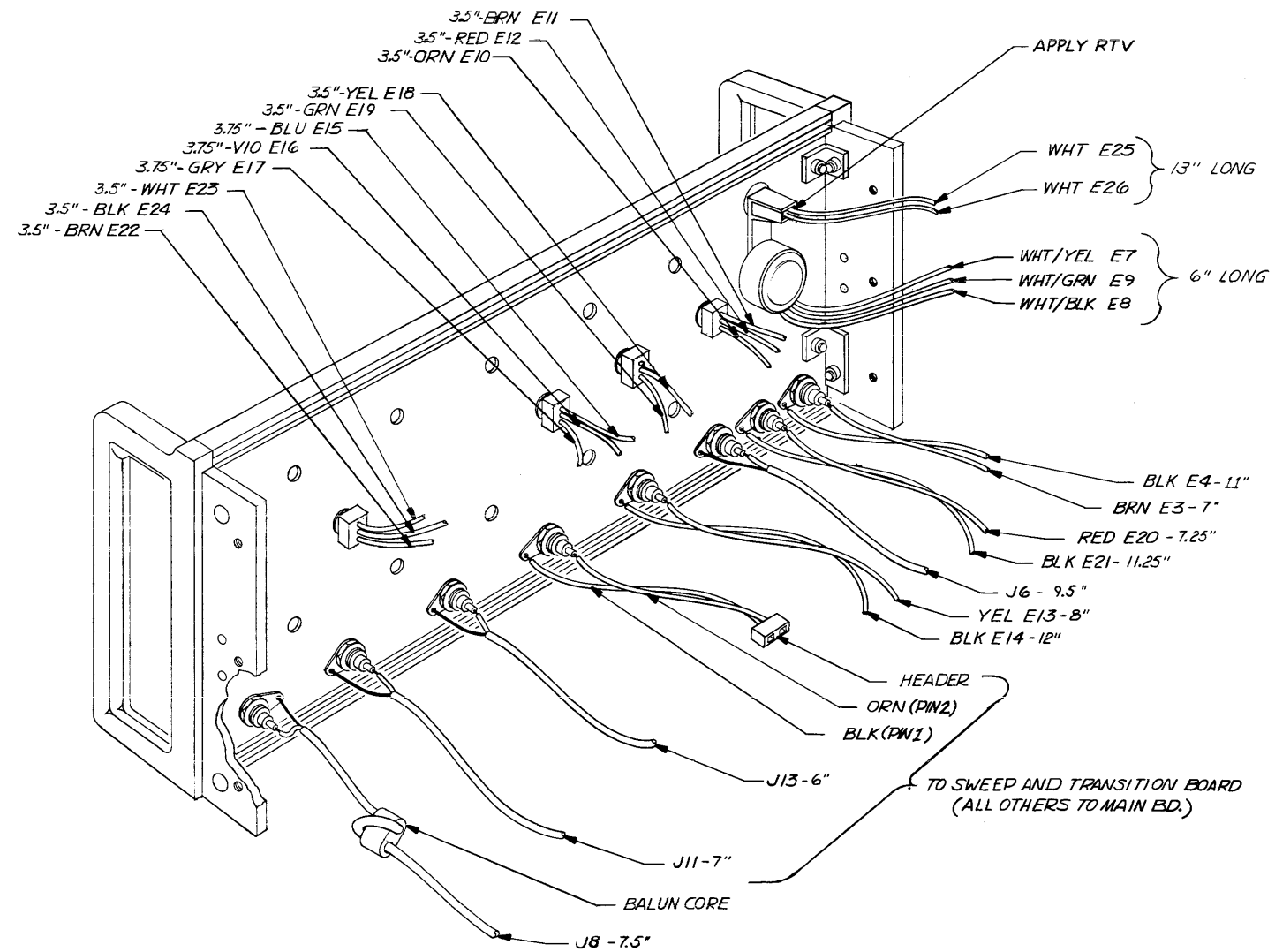

NOTE: UNLESS OTHERWISE SPECIFIED

REMOVE ALL BURRS AND BREAK SHARP EDGES	DRAWN <i>D. COOPER</i>	DATE 5-11-78	WAVETEK SAN DIEGO • CALIFORNIA
MATERIAL	PROJ ENGR <i>Kevin To</i>	DATE 9/27/78	
FINISH WAVETEK PROCESS	TOLERANCE UNLESS OTHERWISE SPECIFIED XXX : .010 ANGLES : 1 XX : .030		TITLE ASSEMBLY CHASSIS
SCALE	DO NOT SCALE DWG	MODEL NO 166	DWG NO 0102-00-0649
	CODE IDENT 23338		REV C
			SHEET 3 OF 3

8

7

6

5

4

3

2

1

REV ECN BY DATE APP

THIS DOCUMENT CONTAINS PROPRIETARY INFORMATION AND DESIGN RIGHTS BELONGING TO WAVETEK AND MAY NOT BE REPRODUCED FOR ANY REASON EXCEPT CALIBRATION, OPERATION, AND MAINTENANCE WITHOUT WRITTEN AUTHORIZATION.

REFERENCE DESIGNATORS	PART DESCRIPTION	ORIG-MFGN-PART-NO	MFGN	WAVETEK NO.	QTY/PRT
NONE	ASSY DRWG CHASSIS	0102-00-0649	WVTK	0102-00-0649	1
NONE	DIAL ASSY	166-0652	WVTK	1201-00-0652	1
1	INDICATOR, DIAL	180-303	WVTK	1400-00-4970	1
2	HANDLE, BLACK FROM: 1400-00-7921	1400-00-7929	WVTK	1400-00-7929	2
4	MNTG ANGLE	1400-00-7953	WVTK	1400-00-7953	2
28	TOP COVER	1400-00-R002	WVTK	1400-00-R002	1
29	BOTTOM COVER	1400-00-P022	WVTK	1400-00-R022	1
5	CHASSIS ASSY	1400-00-R030	WVTK	1400-00-R030	1
6	POWER ROD	1400-00-R041	WVTK	1400-00-R041	1
9	MNTG BRKT, RIGHT	1400-00-R083	WVTK	1400-00-R083	1
8	MNTG BRKT, LEFT	1400-00-P093	WVTK	1400-00-R093	1
10	PANEL, SUB REF: 3200-02-0005	1400-00-R102	WVTK	1400-00-R102	1
11	PANEL, FRONT	1400-00-R110	WVTK	1400-00-R110	1
13	SPRING, POWER ROD REF: 3200-01-0001	1400-00-R280	WVTK	1400-00-R280	1
12	RWC CUNN	KC-7946	KING	2100-01-0002	8
NONE	HOUSING, CONN 3-POS	87099-5	AMP	2100-03-0042	1

WAVETEK PARTS LIST TITLE CHASSIS ASSEMBLY NO. 1101-00-0649 REV C
PAGE: 1

REFERENCE DESIGNATORS	PART DESCRIPTION	ORIG-MFGN-PART-NO	MFGN	WAVETEK NO.	QTY/PRT
14	SOLDER LUG	1497	SMITH	2100-00-0012	8
15	SOLDER LUG	1445-A	SMITH	2100-00-0025	1
NONE	PINS, CONN	8747-2	AMP	2100-05-0030	2
16	STD KNDR	4847-1-SH-W	ROGAY	2400-01-0008	1
17	COAX KNDR SFT	4847-1-SH-W-9	ROGAY	2400-01-0009	8
18	LAMP	(M)-7-76	CHMIN	2400-02-0013	1
19	RUSHING NYLJAFH	4L2FF	THOMN	2800-01-0002	10
26	STANDOFF 1.82PH, .250 HEX, 0-90	PH14-03-F05A-400	AMCP	2800-02-0025	3
20	HAIL ASSY W/FT	147-505	WVTK	2800-08-0007	1
27	SPEEDNUT, SELF RETAIN	C7494-632-4	TJAN	2800-09-0003	6
24	INSERT # A	74-11-106-13	SOICO	2800-09-0017	8
21	WASHER, SHOULDER	2A6A	SMITH	2800-27-0004	16
NONE	RALUM CUHE	28-73-000302	FARJI	3100-00-0005	1
22	SWITCH, TOGGLE	7108 P3DCQN	CKK	5106-00-0003	2
23	SWITCH, TOGGLE	7108 P3DCQN	CKK	5106-00-0006	2

WAVETEK PARTS LIST TITLE CHASSIS ASSEMBLY NO. 1101-00-0649 REV C
PAGE: 2

NOTE: UNLESS OTHERWISE SPECIFIED

REMOVE ALL BURRS AND BREAK SHARP EDGES	DRAWN	DATE	WAVETEK SAN DIEGO • CALIFORNIA	
MATERIAL	PROJ ENGR		TITLE CHASSIS	
	RELEASE APPROV			
FINISH WAVETEK PROCESS	TOLERANCE UNLESS OTHERWISE SPECIFIED XXX .010 ANGLES .1 XX .030		MODEL NO. 166	DWG NO. 1101-00-0649
	DO NOT SCALE DWG	SCALE	REV C	
	SCALE		CODE IDENT 23338	SHEET 1 OF 1

8

7

6

5

4

3

2

1

THIS DOCUMENT CONTAINS PROPRIETARY INFORMATION AND DESIGN RIGHTS BELONGING TO WAVETEK AND MAY NOT BE REPRODUCED FOR ANY REASON EXCEPT CALIBRATION, OPERATION, AND MAINTENANCE WITHOUT WRITTEN AUTHORIZATION.

REV	ECN	BY	DATE	APP
C	ECN 1786	RD	8-15-78	
D	ECN 1877	RD	12-18-78	
E	ECN 2088	DC	1-9-80	
F	ECN 2107	DC	3-6-80	

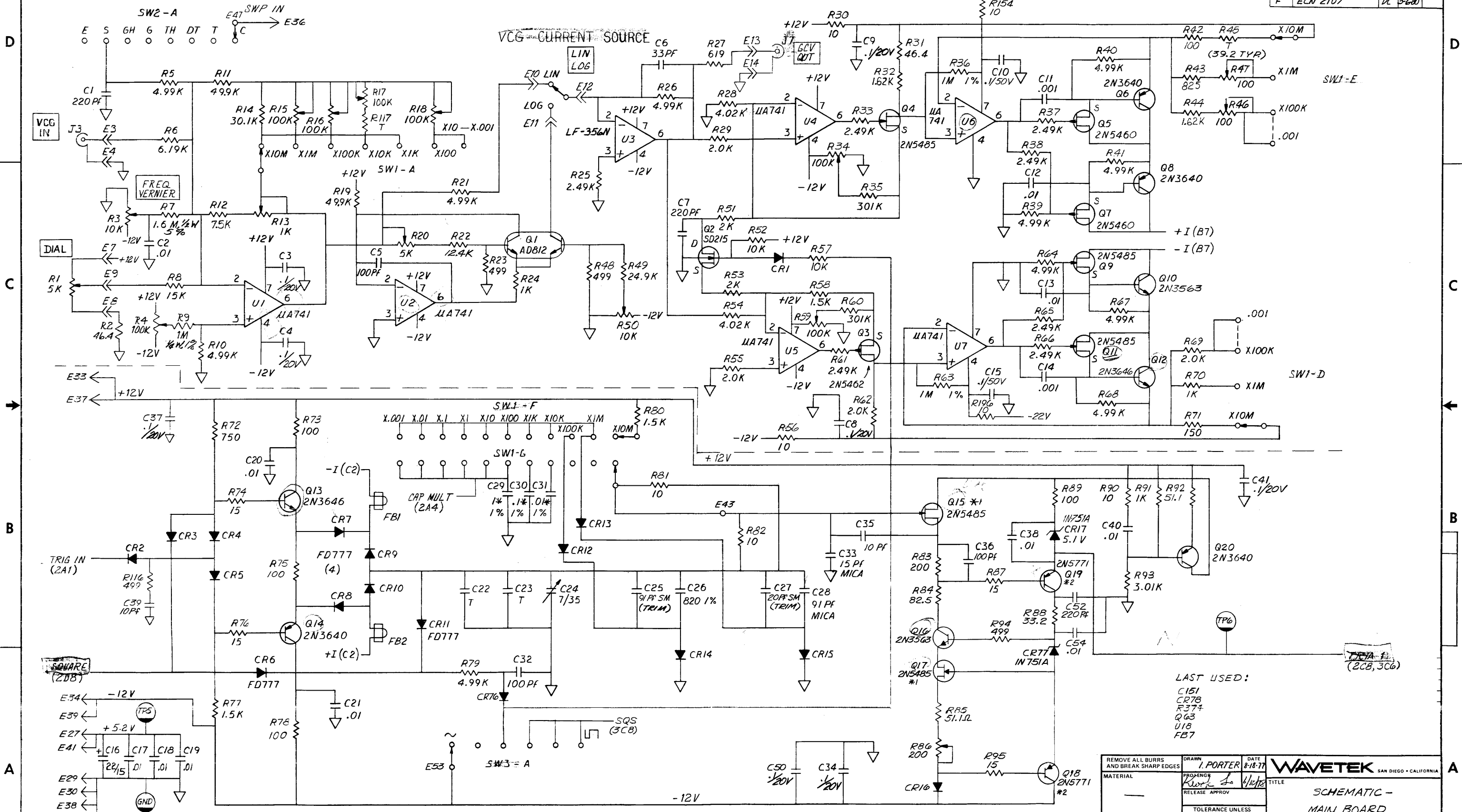

1. ALL DIODES ARE FD6666 * MATCHED SET
NOTE: UNLESS OTHERWISE SPECIFIED

LAST USED:
C151
CR78
R374
Q63
U18
FB7

REMOVE ALL BURRS AND BREAK SHARP EDGES	DRAWN I. PORTER	DATE 8-18-77	WAVETEK SAN DIEGO • CALIFORNIA
MATERIAL	PROF. ENGR. <i>[Signature]</i>	DATE 4/1/78	
FINISH WAVETEK PROCESS	RELEASE APPROV	TOLERANCE UNLESS OTHERWISE SPECIFIED .XXX - .010 ANGLES - 1° .XX - .030	TITLE SCHEMATIC - MAIN BOARD
SCALE	DO NOT SCALE DWG	MODEL NO. 166	DWG NO. 0103-00-0628
		CODE IDENT 23338	REV F

TRIANGLE AMP

THIS DOCUMENT CONTAINS PROPRIETARY INFORMATION AND DESIGN RIGHTS BELONGING TO WAVETEK AND MAY NOT BE REPRODUCED FOR ANY REASON EXCEPT CALIBRATION, OPERATION, AND MAINTENANCE WITHOUT WRITTEN AUTHORIZATION.

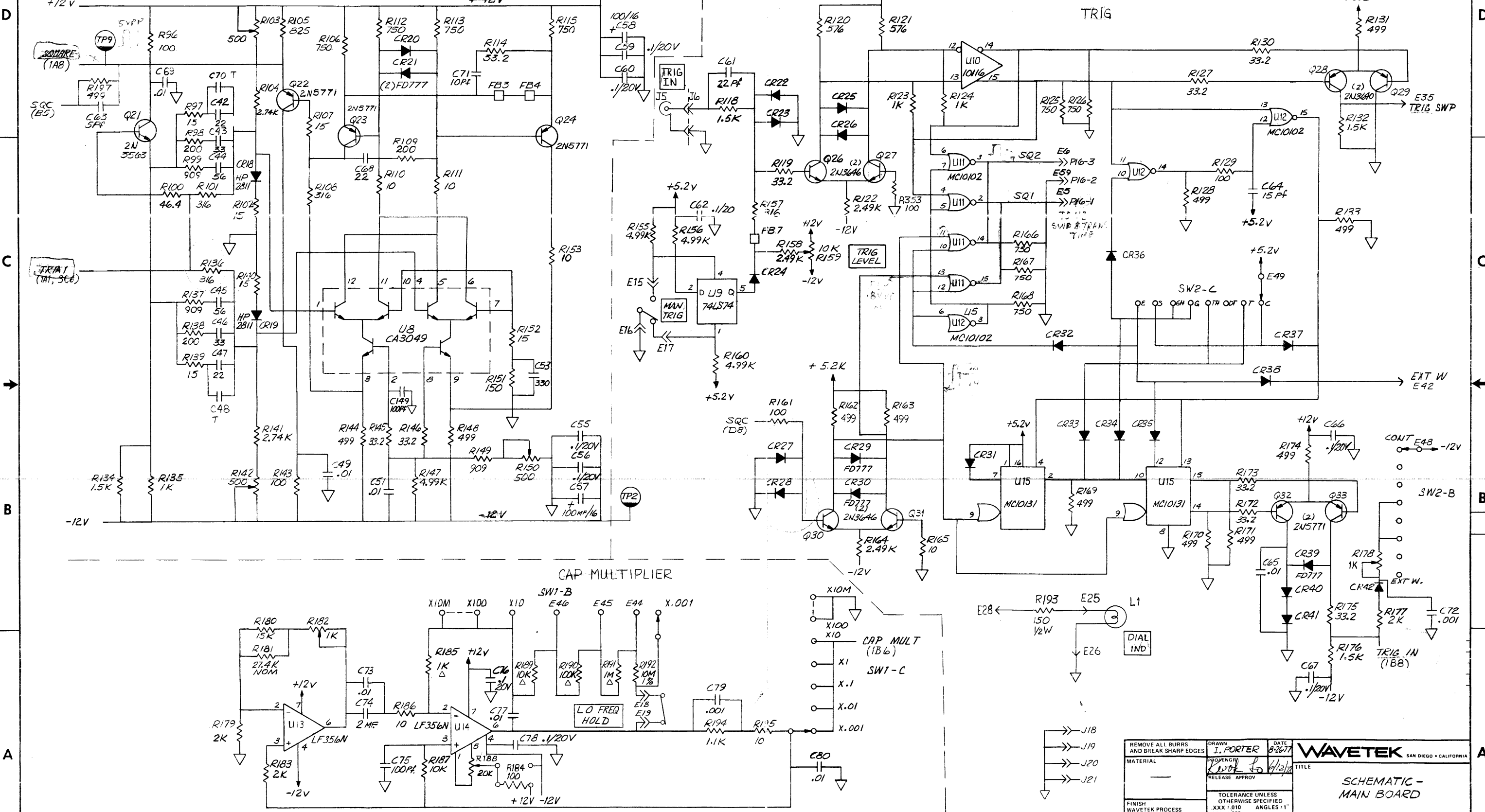

NOTE: UNLESS OTHERWISE SPECIFIED

Δ MATCHED SET

REMOVE ALL BURRS AND BREAK SHARP EDGES	DRAWN	I. PORTER	DATE	8-28-77
	PROVEN	LD	DATE	4/12/78
MATERIAL	RELEASE	APPROV		
	TITLE			
FINISH WAVETEK PROCESS	TOLERANCE UNLESS OTHERWISE SPECIFIED		MODEL NO	166
	DO NOT SCALE DWG		DWG NO	0103-00-0628
SCALE	SCALE		REV	F
CODE IDENT		23338	SHEET 2 OF 3	

THIS DOCUMENT CONTAINS PROPRIETARY INFORMATION AND DESIGN RIGHTS BELONGING TO WAVETEK AND MAY NOT BE REPRODUCED FOR ANY REASON EXCEPT CALIBRATION, OPERATION, AND MAINTENANCE WITHOUT WRITTEN AUTHORIZATION.

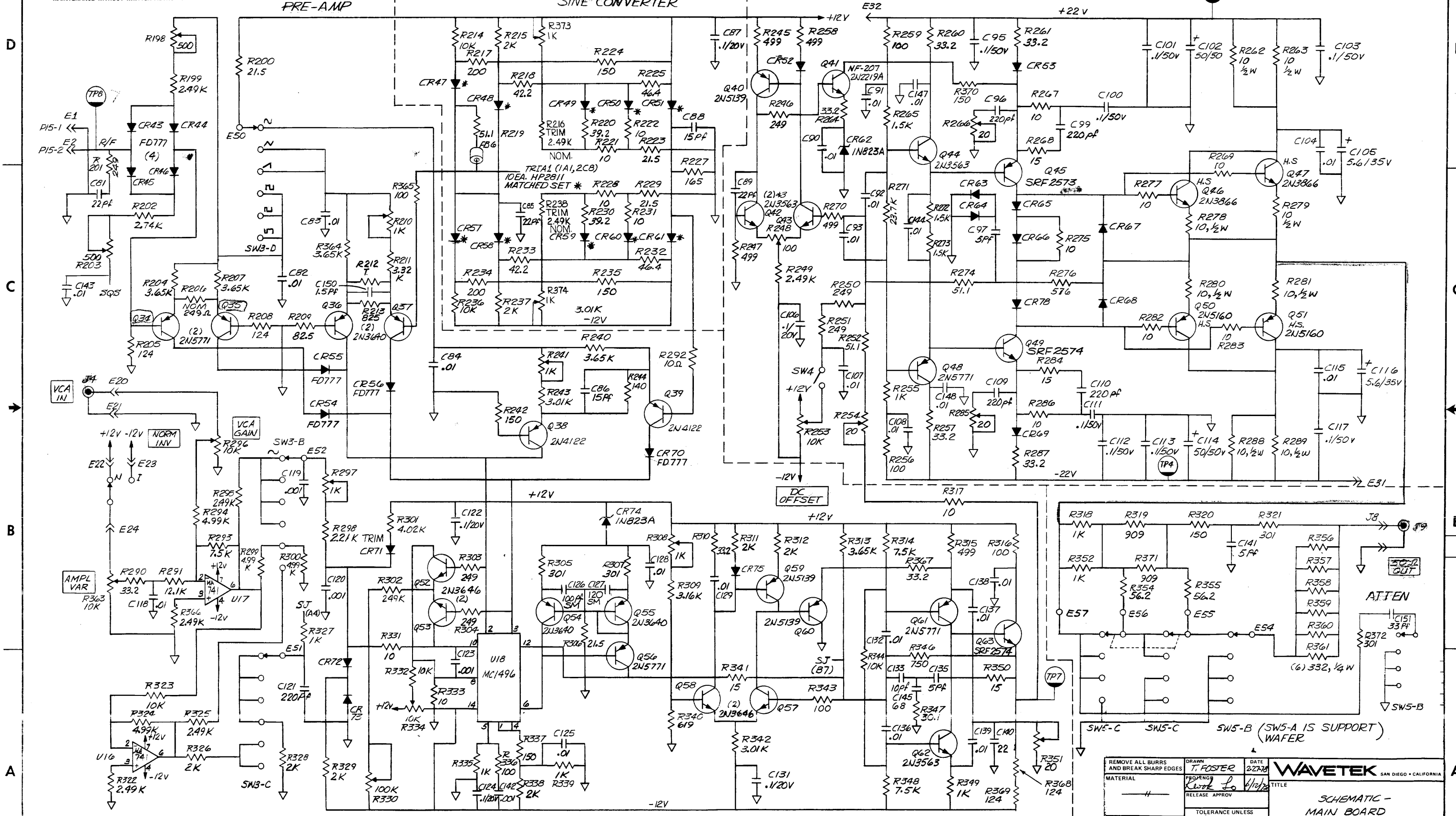

1. *3 INDICATES MATCHED SET
NOTE: UNLESS OTHERWISE SPECIFIED

REMOVE ALL BURRS AND BREAK SHARP EDGES		DRAWN T. FOSTER	DATE 2/27/78	WAVETEK SAN DIEGO • CALIFORNIA
MATERIAL		PROPOSED K. L. L.	DATE 6/19/78	
FINISH WAVETEK PROCESS		RELEASE APPROV		TITLE SCHEMATIC - MAIN BOARD
DO NOT SCALE DWG		TOLERANCE UNLESS OTHERWISE SPECIFIED XXX : 010 ANGLES 1:1 XX : 030		MODEL NO. 166
SCALE		SCALE		DWG NO. 0103-00-0628 F
				REV F
				CODE IDENT 23338
				SHEET 3 OF 3

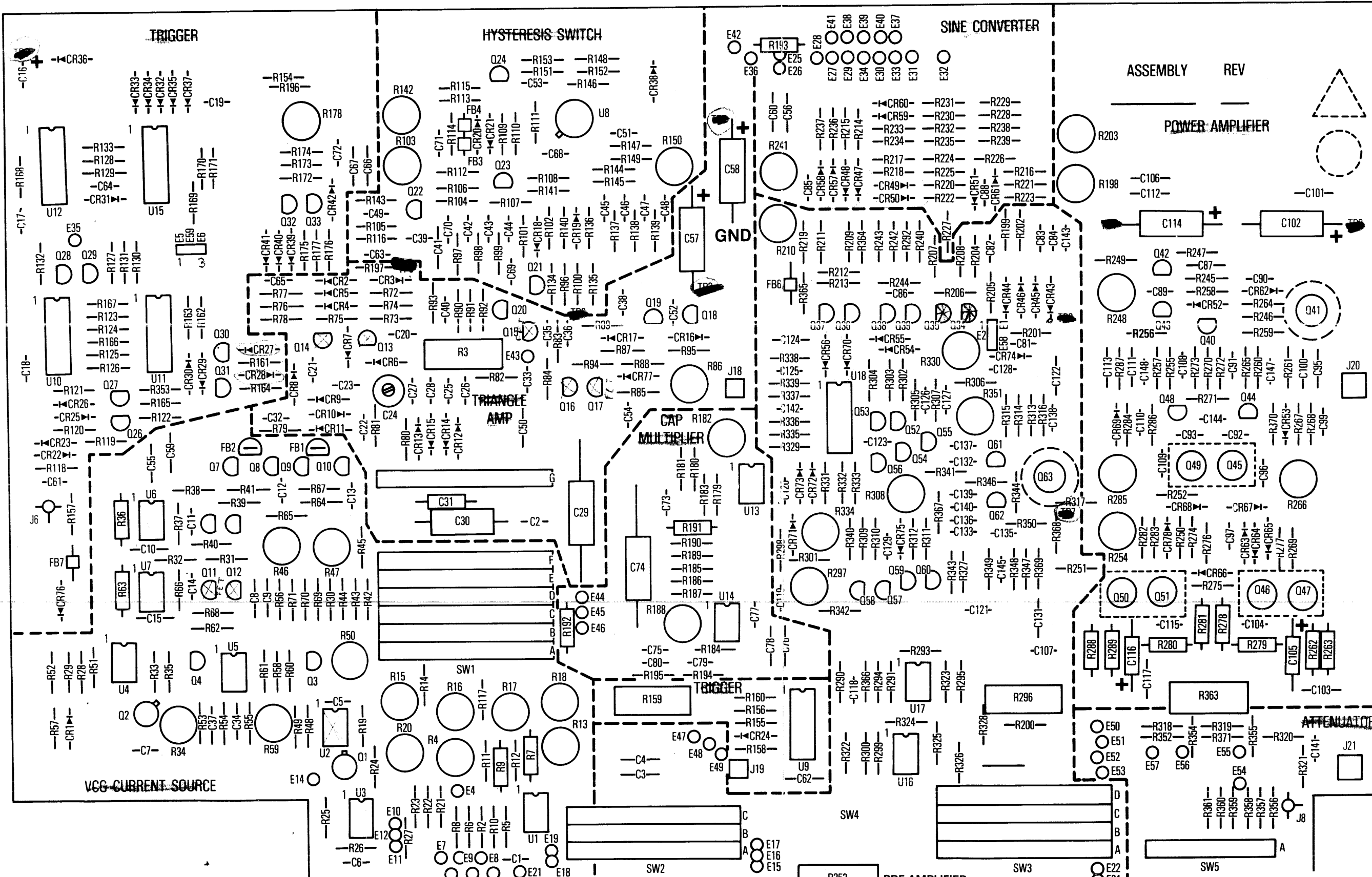

ASSEMBLY REV

POWER AMPLIFIER

ATTENUATOR

REMOVE ALL BURRS AND BREAK SHARP EDGES		DATE	WAVETEK SAN DIEGO • CALIFORNIA	
MATERIAL	PROJ ENGR	TITLE	ASSEMBLY MAIN BOARD	
FINISH WAVETEK PROCESS	RELEASE APPROV	TOLERANCE UNLESS OTHERWISE SPECIFIED	MODEL NO	DWG NO
	SCALE	DO NOT SCALE DWG	166	0101-00-0628
		SCALE	REV	
		CODE IDENT	23338	SHEET 1 OF 2

THIS DOCUMENT CONTAINS PROPRIETARY INFORMATION AND DESIGN RIGHTS BELONGING TO WAVETEK AND MAY NOT BE REPRODUCED FOR ANY REASON EXCEPT CALIBRATION, OPERATION, AND MAINTENANCE WITHOUT WRITTEN AUTHORIZATION.

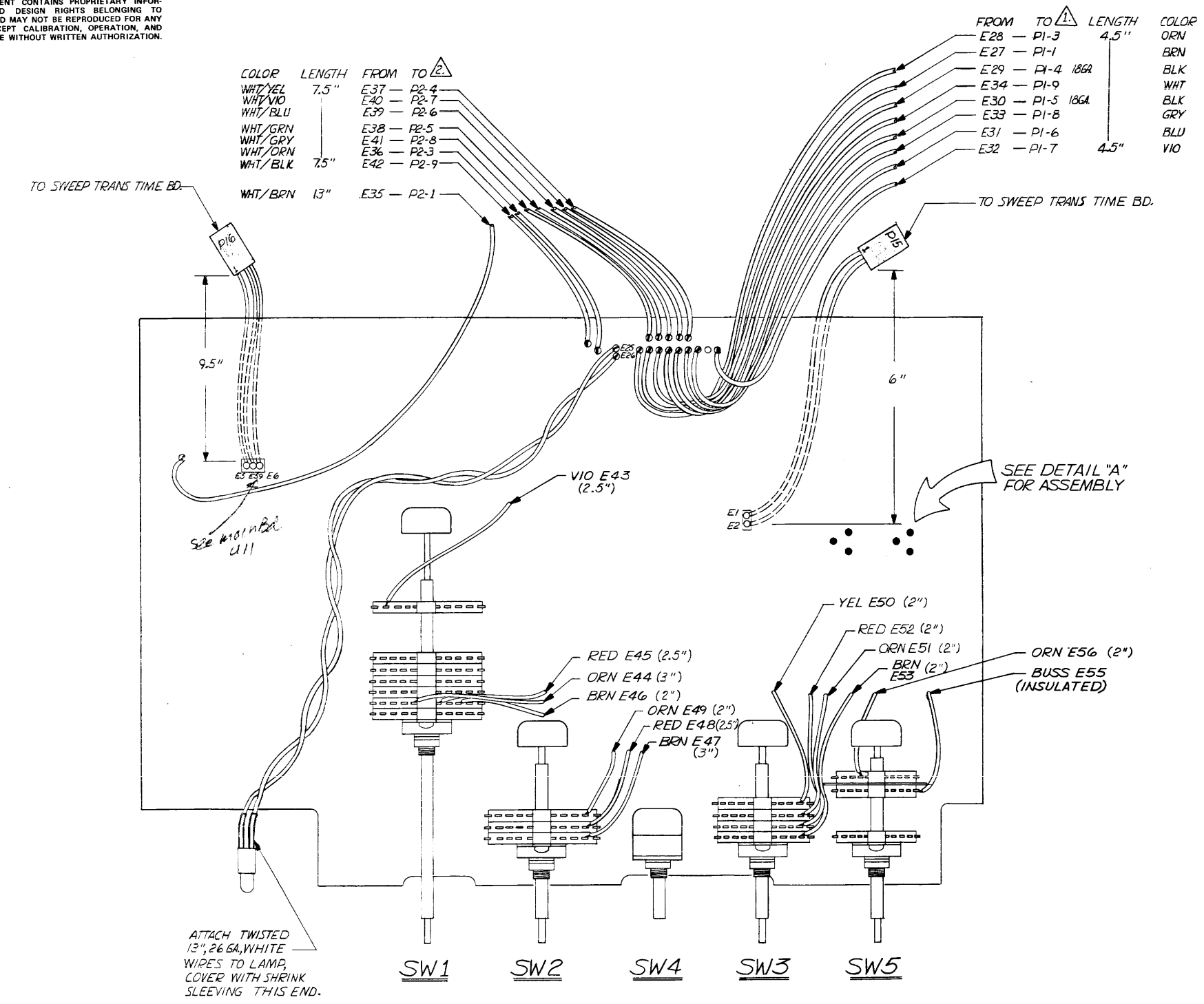

DETAIL "A"
TRANSISTOR HEATSINK HARDWARE STACK-UP

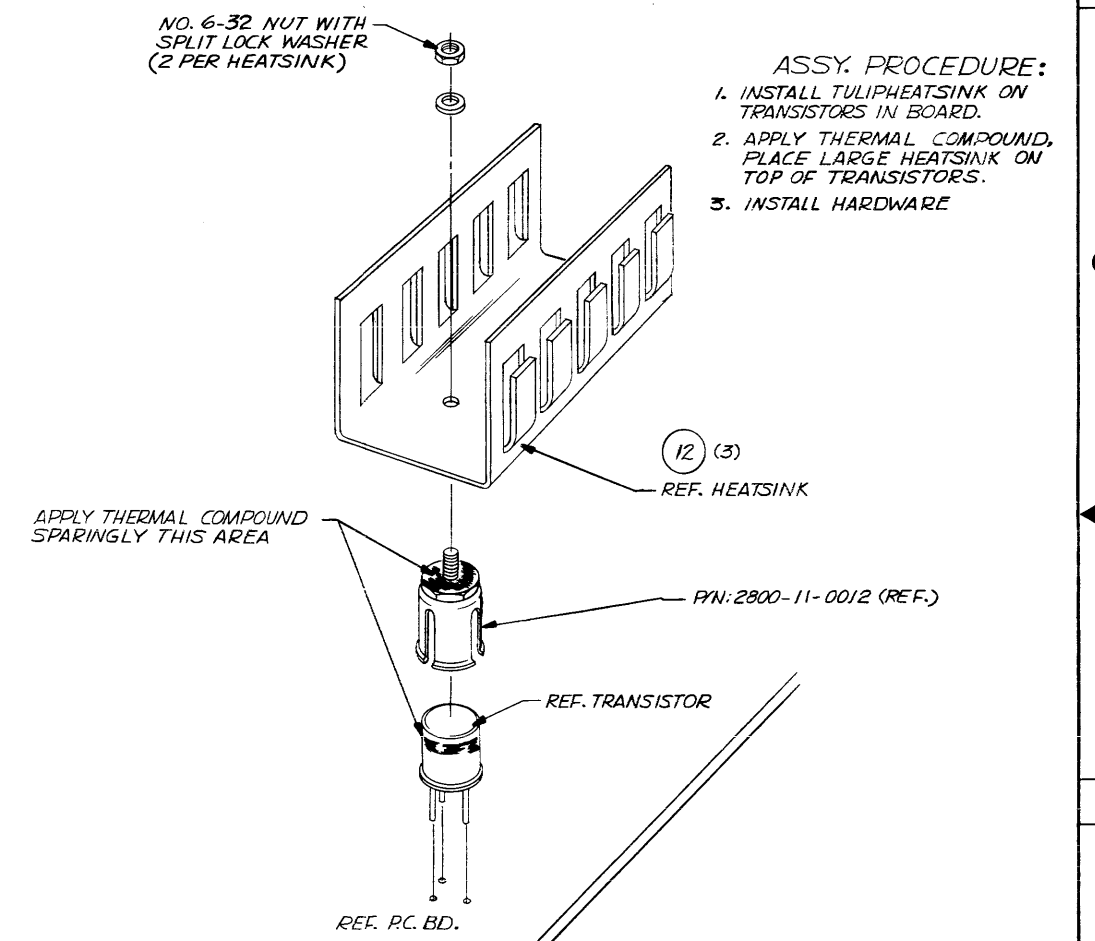

△ MOLEX CONN. (P2) GOES TO SWEEP TRANS TIME BD.
 △ MOLEX CONN. (P1) GOES TO POWER SUPPLY BD.

NOTE UNLESS OTHERWISE SPECIFIED

REMOVE ALL BURRS AND BREAK SHARP EDGES	DRAWN D. COOPER	DATE 3/31/78	WAVETEK SAN DIEGO • CALIFORNIA	
MATERIAL	PROV. ENGR R. COOPER	DATE 6/12/78	TITLE ASSEMBLY MAIN BOARD	
FINISH WAVETEK PROCESS	RELEASE APPROV	TOLERANCE UNLESS OTHERWISE SPECIFIED .XXX ± 0.10 ANGLES ± 1° XX ± 0.30	MODEL NO. 166	DWG NO. 0101-00-0628
SCALE	DO NOT SCALE DWG	SCALE	REV D	REV
	CODE IDENT 23338		SHEET 2	OF 2

8

7

6

5

↓

4

3

2

1

REV ECN BY DATE APP

THIS DOCUMENT CONTAINS PROPRIETARY INFORMATION AND DESIGN RIGHTS BELONGING TO WAVETEK AND MAY NOT BE REPRODUCED FOR ANY REASON EXCEPT CALIBRATION, OPERATION, AND MAINTENANCE WITHOUT WRITTEN AUTHORIZATION.

Table with 6 columns: REFERENCE DESIGNATORS, PART DESCRIPTION, ORIG-MFGR-PART-NO, MFGR, WAVETEK NO., QTY/PT. Includes parts like ASSY DRWG MAIN, SCHEMATIC MAIN, ASSY SWITCHES MAINBOARD, HEATSINK, MOD FROM:2800-11-0011, CAP,CER,5PF,1KV, CAP,CER,10PF,1KV, CAP,CER,100PF,1KV, CAP,CER,100PF,1KV, CAP,CER,100PF,1KV, CAP,CER,.001MF,1KV, CAP,CER,.01MF,50V, CAP,CER,.01MF,100V, CAP,CER,.01MF,100V, MAIN BD, CONN,9PIN, CONN.

Table with 6 columns: REFERENCE DESIGNATORS, PART DESCRIPTION, ORIG-MFGR-PART-NO, MFGR, WAVETEK NO., QTY/PT. Includes parts like CAP,MICA,91PF,500V, CAP,ELECT,100MF,16V, CAP,ELECT,50MF,50V, CAP,MYLR,2MF,200V, VARI,7-35PF,250V, CAP,TANT,22MF,15V, CAP,TANT,5.6MF,35V, CAP SET,POLY MIXED MATCHED SET, CAP,POLY,1MF,100V, CAP,POLY,.1MF,100V, CAP,POLY,.01MF,100V, MAIN BD, CONN,9PIN, CONN.

Table with 6 columns: REFERENCE DESIGNATORS, PART DESCRIPTION, ORIG-MFGR-PART-NO, MFGR, WAVETEK NO., QTY/PT. Includes parts like POT,TRIM,10K, POT,TRIM,100K, POT,TRIM,20, POT,TRIM,200, POT,TRIM,20K, POT,TRIM,500, POT,TRIM,5K, POT,SWITCH,10K, RES,C,1/2W,5%,10, RES,C,1/2W,10%,150, RES,C,1/2W,5%,1.6M, RES,MF,1/8W,1%,100, RES,MF,1/8W,1%,1K.

Table with 6 columns: REFERENCE DESIGNATORS, PART DESCRIPTION, ORIG-MFGR-PART-NO, MFGR, WAVETEK NO., QTY/PT. Includes parts like CAP,CER,.1MF,20V, CAP,CER,15PF,1KV, CAP,CER,1.5PF,1KV, CAP,CER,22PF,1KV, CAP,CER,220PF,1KV, CAP,CER,33PF,1KV, CAP,CER,330PF,1KV, CAP,CER,56PF,1KV, CAP,CER,68PF,1KV, CAP,MICA,100PF,500V, CAP,MICA,120PF,500V, CAP,MICA,15PF,500V, CAP,MICA,20PF,500V, CAP,MICA,20PF,300V.

Table with 6 columns: REFERENCE DESIGNATORS, PART DESCRIPTION, ORIG-MFGR-PART-NO, MFGR, WAVETEK NO., QTY/PT. Includes parts like SPRING SOCKET, COAX SOCKET, CABLE CONTACT, HOUSING,CONN 3-POS, TERM, PIN, PINS,CONN, STANDOFF,SWAGE .687 H,.250 HEX 4-40,.062 MAT'L, HEAT SINK, TRANSIPAD, HEATSINK, FERRITE BEAD, BALUN CORE, POT,TRIM,100, POT,TRIM,1K.

Table with 6 columns: REFERENCE DESIGNATORS, PART DESCRIPTION, ORIG-MFGR-PART-NO, MFGR, WAVETEK NO., QTY/PT. Includes parts like RES,MF,1/8W,1%,10K, RES,MF,1/8W,1%,10, RES,MF,1/8W,1%,1.1K, RES,MF,1/8W,1%,12.1K, RES,MF,1/8W,1%,124, RES,MF,1/8W,1%,12.4K, RES,MF,1/8W,1%,140, RES,MF,1/8W,1%,150, RES,MF,1/8W,1%,1.5K, RES,MF,1/8W,1%,15K, RES,MF,1/8W,1%,15.

Technical drawing header and title block. Includes 'WAVETEK PARTS LIST', 'TITLE PCA,MAIN BD', 'ASSEMBLY NO. 1100-00-0628', 'REV F', 'PAGE: 1', 'PAGE: 2', 'PAGE: 3', 'PAGE: 4', 'PAGE: 5', 'PAGE: 6'. Title block contains 'WAVETEK SAN DIEGO • CALIFORNIA', 'TITLE MAIN BOARD', 'MODEL NO 166', 'DWG NO 1100-00-0628', 'REV F', 'SCALE', 'CODE IDENT 23338', 'SHEET 1 OF 3'. Includes 'REMOVE ALL BURRS AND BREAK SHARP EDGES', 'DRAWN', 'DATE', 'PROJENGR', 'RELEASE APPROV', 'TOLERANCE UNLESS OTHERWISE SPECIFIED', 'XXX .010 ANGLES .1 XX -.030', 'DO NOT SCALE DWG', 'SCALE', 'FINISH WAVETEK PROCESS'.

NOTE: UNLESS OTHERWISE SPECIFIED

8

7

6

5

↑

4

3

2

1

8

7

6

5

4

3

2

1

REV ECN BY DATE APP

THIS DOCUMENT CONTAINS PROPRIETARY INFORMATION AND DESIGN RIGHTS BELONGING TO WAVETEK AND MAY NOT BE REPRODUCED FOR ANY REASON EXCEPT CALIBRATION, OPERATION, AND MAINTENANCE WITHOUT WRITTEN AUTHORIZATION.

D

Table with 6 columns: REFERENCE DESIGNATORS, PART DESCRIPTION, ORIG-MFGR-PART-NO, MFGR, WAVETEK NO., QTY/PT. Includes parts like R350 R74 R76 R87 R95 R97, R32 R44, R227, etc.

Table with 6 columns: REFERENCE DESIGNATORS, PART DESCRIPTION, ORIG-MFGR-PART-NO, MFGR, WAVETEK NO., QTY/PT. Includes parts like R116 R128 R131 R133, R144 R148 R162 R163, etc.

Table with 6 columns: REFERENCE DESIGNATORS, PART DESCRIPTION, ORIG-MFGR-PART-NO, MFGR, WAVETEK NO., QTY/PT. Includes parts like CR10 CR11 CR20 CR21, CR29 CR30 CR39 CR43, etc.

D

C

C

Summary table for the first table: WAVETEK PARTS LIST, TITLE PCA, MAIN BD, ASSEMBLY NO. 1100-00-0628, PAGE: 7, REV F

Summary table for the second table: WAVETEK PARTS LIST, TITLE PCA, MAIN BD, ASSEMBLY NO. 1100-00-0628, PAGE: 9, REV F

Summary table for the third table: WAVETEK PARTS LIST, TITLE PCA, MAIN BD, ASSEMBLY NO. 1100-00-0628, PAGE: 11, REV F

B

B

Table with 6 columns: REFERENCE DESIGNATORS, PART DESCRIPTION, ORIG-MFGR-PART-NO, MFGR, WAVETEK NO., QTY/PT. Includes parts like R1811, R305 R307 R321, R243 R342 R93, etc.

Table with 6 columns: REFERENCE DESIGNATORS, PART DESCRIPTION, ORIG-MFGR-PART-NO, MFGR, WAVETEK NO., QTY/PT. Includes parts like R209 R84, R137 R149 R319 R371 R99, etc.

Table with 6 columns: REFERENCE DESIGNATORS, PART DESCRIPTION, ORIG-MFGR-PART-NO, MFGR, WAVETEK NO., QTY/PT. Includes parts like Q46 Q47, Q38 Q39, Q40 Q59 Q60, etc.

Summary table for the fourth table: WAVETEK PARTS LIST, TITLE PCA, MAIN BD, ASSEMBLY NO. 1100-00-0628, PAGE: 8, REV F

Summary table for the fifth table: WAVETEK PARTS LIST, TITLE PCA, MAIN BD, ASSEMBLY NO. 1100-00-0628, PAGE: 10, REV F

Summary table for the sixth table: WAVETEK PARTS LIST, TITLE PCA, MAIN BD, ASSEMBLY NO. 1100-00-0628, PAGE: 12, REV F

A

A

NOTE: UNLESS OTHERWISE SPECIFIED

Engineering drawing header and title block. Includes fields for REMOVE ALL BURRS, DRAWN, DATE, PROJ ENGR, RELEASE APPROV, TOLERANCE UNLESS OTHERWISE SPECIFIED, DO NOT SCALE DWG, SCALE, MODEL NO. 166, DWG NO. 1100-00-0628, REV F, CODE IDENT 23338, SHEET 2 OF 3.

8

7

6

5

4

3

2

1

8

7

6

5

4

3

2

1

REV ECN BY DATE APP

THIS DOCUMENT CONTAINS PROPRIETARY INFORMATION AND DESIGN RIGHTS BELONGING TO WAVETEK AND MAY NOT BE REPRODUCED FOR ANY REASON EXCEPT CALIBRATION, OPERATION, AND MAINTENANCE WITHOUT WRITTEN AUTHORIZATION.

D

D

C

C

B

B

A

A

REFERENCE DESIGNATORS	PART DESCRIPTION	ORIG-MFGR-PART-NO	MFGR	WAVETEK NO.	QTY/PT
U1 U16 U17 U2 U4 U5 U6 U7	IC	MA-741	FAIR	7000-07-0100	8
Q1	IC	AD 812	ANDEV	7000-08-1200	1
U18	IC	MC1496P	MDT	7000-14-9600	1
U8	IC	CA-3049	RCA	7000-30-4900	1
U9	IC	74LS74	TI	8000-74-7410	1
U11 U12	IC	MC10102	MDT	8001-01-0200	2
U10	IC	MC10116P	MDT	8001-01-1600	1
U15	IC	MC10131	MDT	8001-01-3100	1

WAVETEK
PARTS LIST

TITLE
PCA, MAIN BD

ASSEMBLY NO.
1100-00-0628

REV
F

PAGE: 13

NOTE: UNLESS OTHERWISE SPECIFIED

REMOVE ALL BURRS AND BREAK SHARP EDGES		DRAWN	DATE	WAVETEK SAN DIEGO • CALIFORNIA	
MATERIAL		PROJ ENGR	TITLE		
FINISH WAVETEK PROCESS		RELEASE APPROV	MAIN BOARD		
		TOLERANCE UNLESS OTHERWISE SPECIFIED XXX : 010 ANGLES : 1 XX : 030		MODEL NO	DWG NO
		DO NOT SCALE DWG		166	1100-00-0628
		SCALE		REV	F
		CODE IDENT	23338	SHEET 3 OF 5	

8

7

6

5

4

3

2

1

REV	ECN	BY	DATE	APP
A	ECN 1878	D. Cooper	12-19-78	

THIS DOCUMENT CONTAINS PROPRIETARY INFORMATION AND DESIGN RIGHTS BELONGING TO WAVETEK AND MAY NOT BE REPRODUCED FOR ANY REASON EXCEPT CALIBRATION, OPERATION, AND MAINTENANCE WITHOUT WRITTEN AUTHORIZATION.

TYPICAL HARDWARE STACK-UP

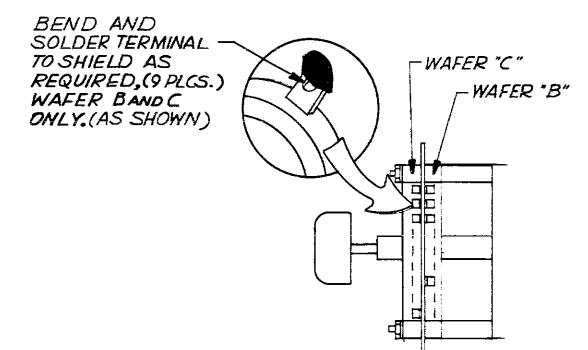
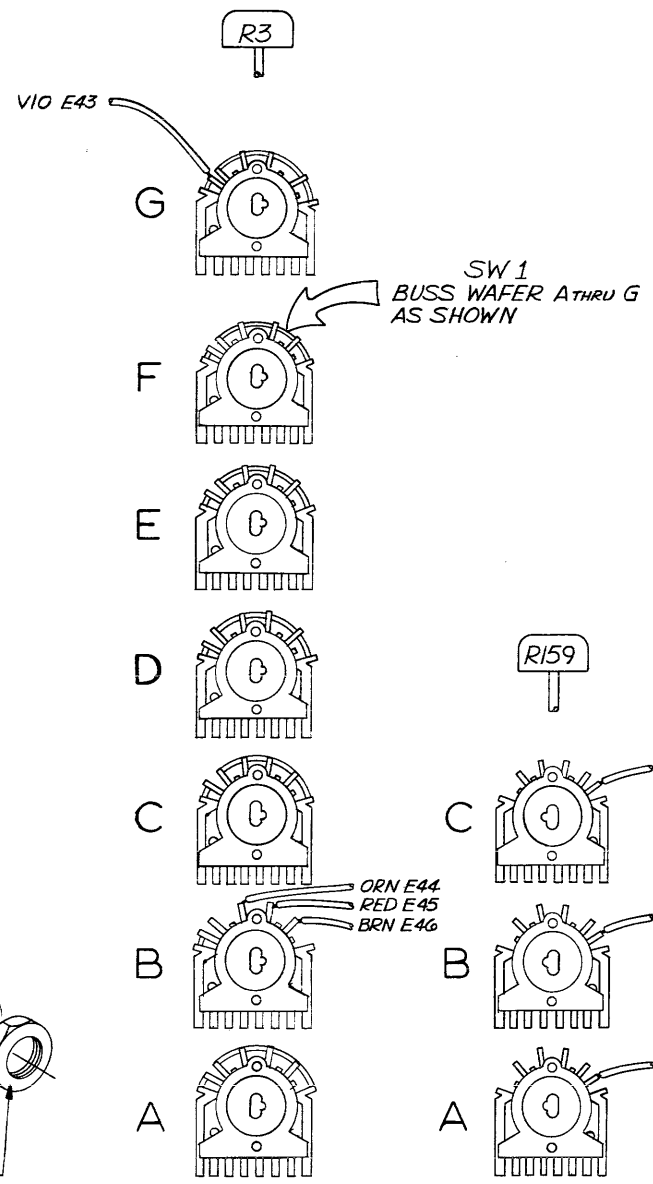
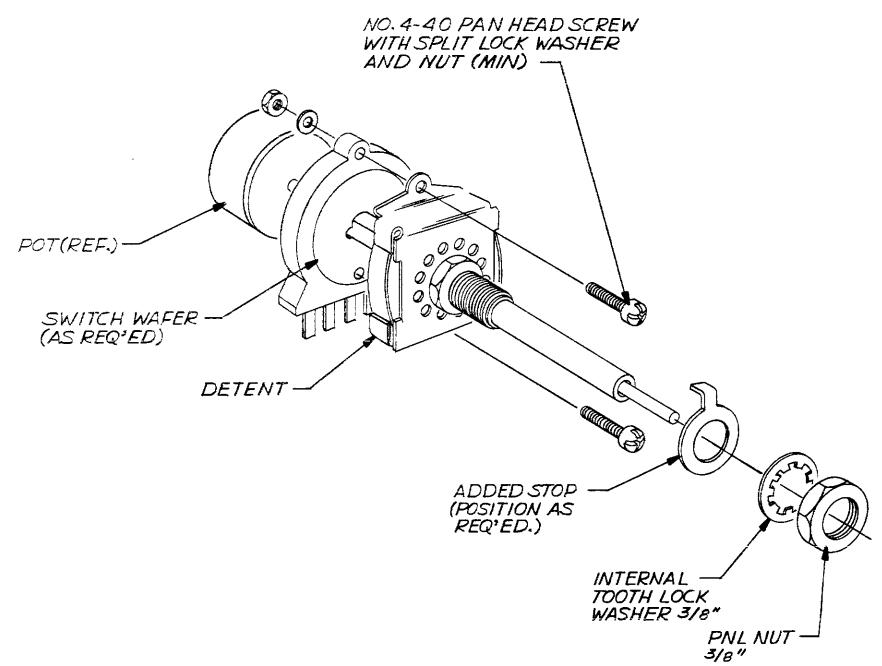

VIEW "A" TERMINAL PREP AND SOLDER

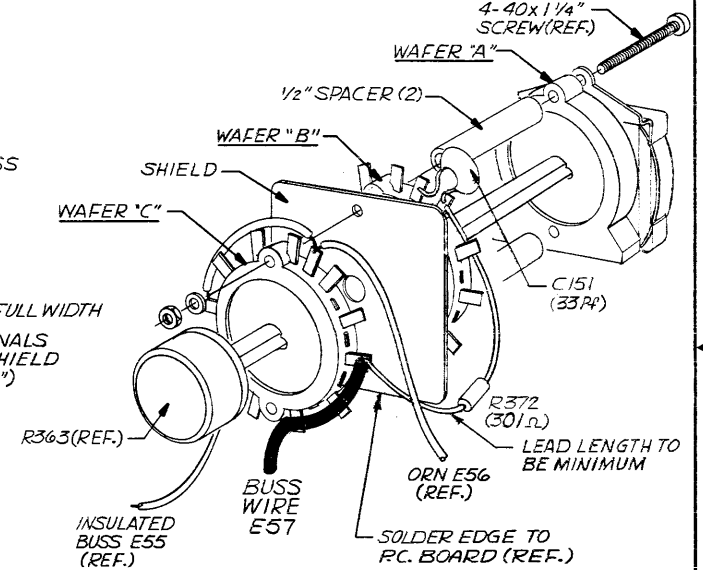

DETAIL "A" SHIELD INSTALLATION SW5

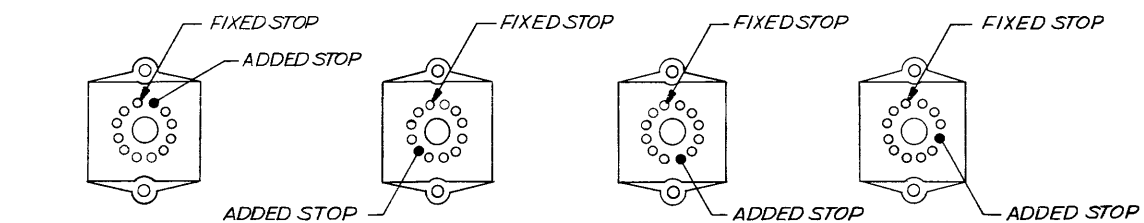

- SW1 WIRING DETAIL
WAFFER A,B,C,D,E, AND F
4-40x1 1/4"
DETENT: 5104-99-0040
- SW2 WIRING DETAIL
WAFFER A,B AND C 4-40x3/4"
5104-99-0041
- SW3 WIRING DETAIL
WAFFER A,B,C, AND D
4-40x7/8"
5104-99-0041
- SW5 WIRING DETAIL
WAFFER A,B, AND C
4-40x1 1/4" SEE DETAIL "A"
5104-99-0041

- SW1: TURN DETENT FULL CW, ADD STOP-TURN FULL CCW, ADD WAFERS
NOTE: UNLESS OTHERWISE SPECIFIED

REMOVE ALL BURRS AND BREAK SHARP EDGES	DRAWN D. COOPER	DATE 4-4-78	WAVETEK SAN DIEGO - CALIFORNIA	
MATERIAL	PROJ ENGR R. H. F.	DATE 6/14/78	TITLE ASSEMBLY MAIN BOARD SWITCHES	
FINISH WAVETEK PROCESS	TOLERANCE UNLESS OTHERWISE SPECIFIED XXX ± .010 ANGLES :1° XX = .030		MODEL NO 166	DWG NO 1202-00-0041
SCALE	DO NOT SCALE DWG	CODE IDENT 23338	SHEET 2	REV A

8

7

6

5

↓

4

3

2

1

THIS DOCUMENT CONTAINS PROPRIETARY INFORMATION AND DESIGN RIGHTS BELONGING TO WAVETEK AND MAY NOT BE REPRODUCED FOR ANY REASON EXCEPT CALIBRATION, OPERATION, AND MAINTENANCE WITHOUT WRITTEN AUTHORIZATION.

REV	ECN	BY	DATE	APP
B	ECN 1791	RD	8/18/78	KJS

REFERENCE DESIGNATIONS	PART DESCRIPTION	ORIG-MFR-PART-NO	MFR	WAVETEK NO.	QTY/PK
NONE	ASSY DRWG, SHIELD BD	0101-00-0684	AVTK	0101-00-0684	1
NONE	SHIELD BOARD	1700-00-0684	AVTK	1700-00-0684	1
NONE	CONN PIN, MALE (UDY-EA PIN)	CA-536SP-100-230-830	CA	2100-05-0034	6
NONE	STANDOFF	9531R-0440-5A	AMTM	2800-03-0004	2

WAVETEK PARTS LIST	TITLE PCA, SHIELD BOARD	ASSEMBLY NO. 1100-00-0684	REV A
	PAGE: 1		

NO. 4-40x 1/8" STAND OFF
(2 REQ'D.) FAR SIDE

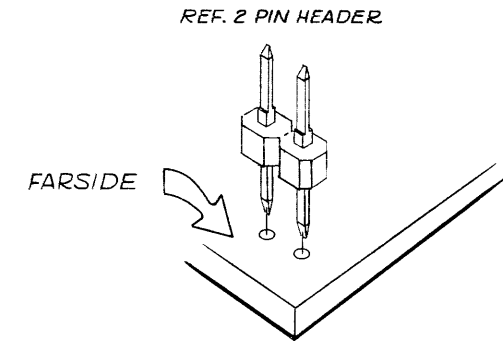
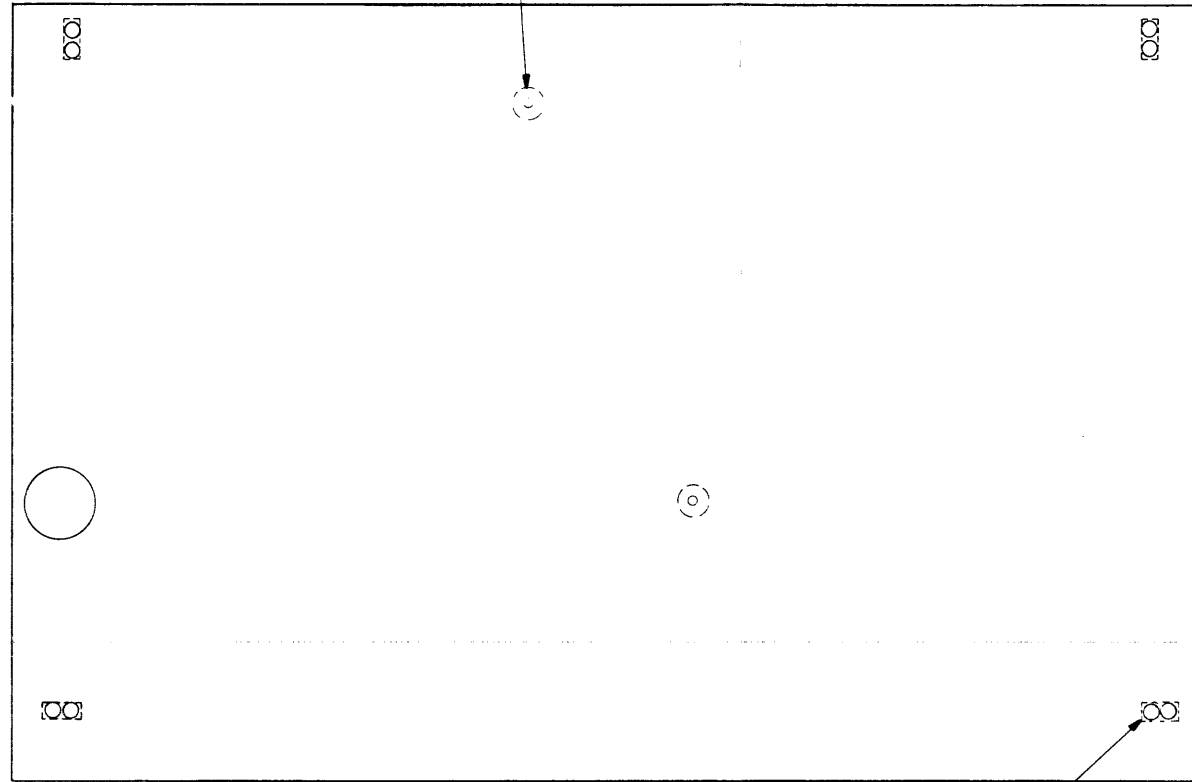

2 PIN HEADER
(8 REQ'D.)
FAR SIDE

NOTE: UNLESS OTHERWISE SPECIFIED

REMOVE ALL BURRS AND BREAK SHARP EDGES	DRAWN D. COOPER	DATE 3/29/78	WAVETEK SAN DIEGO • CALIFORNIA
MATERIAL	PROJ ENGR KJS	RELEASE APPROV	
FINISH WAVETEK PROCESS	TOLERANCE UNLESS OTHERWISE SPECIFIED XXX - .010 ANGLES : 1 XX - .030		TITLE ASSEMBLY SHIELD MAIN BD.
SCALE	DO NOT SCALE DWG	MODEL NO. 166	DWG NO. 0101-00-0684
		CODE IDENT 23338	REV B
			SHEET / OF /

8

7

6

5

↑

4

3

2

1

REV	ECN	BY	DATE	APP
A		TLF	8/31/77	
B	#1934	TLF	8/18/79	
C	#2088	DC	1/9/80	

THIS DOCUMENT CONTAINS PROPRIETARY INFORMATION AND DESIGN RIGHTS BELONGING TO WAVETEK AND MAY NOT BE REPRODUCED FOR ANY REASON EXCEPT CALIBRATION, OPERATION, AND MAINTENANCE WITHOUT WRITTEN AUTHORIZATION.

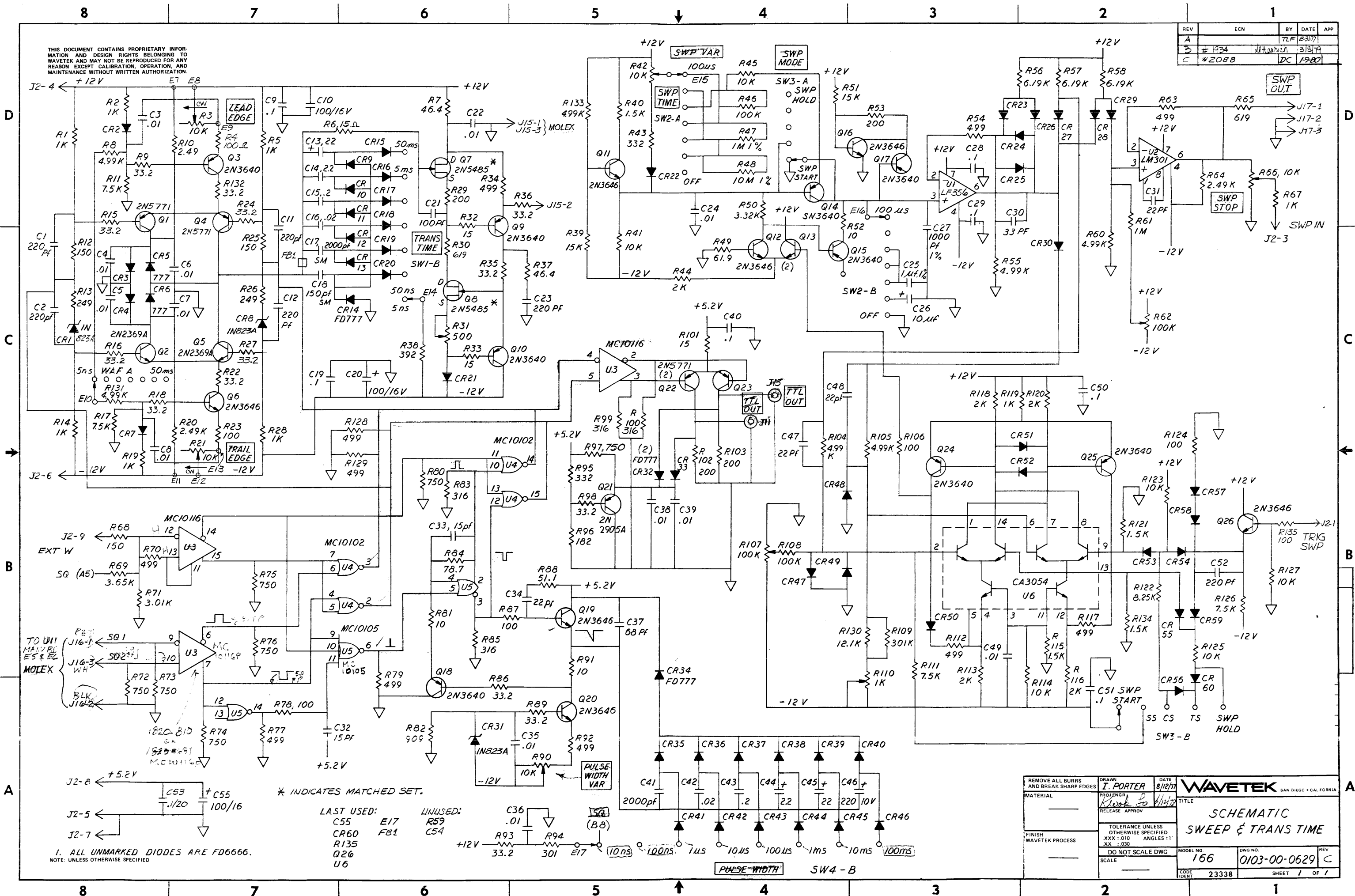

* INDICATES MATCHED SET.

- LAST USED: C55 E17 R59 CR60 FB1 C54
- UNUSED: R135 Q26 U6

1. ALL UNMARKED DIODES ARE FD6666.
NOTE: UNLESS OTHERWISE SPECIFIED

REMOVE ALL BURRS AND BREAK SHARP EDGES	DRAWN I. PORTER	DATE 8/12/77	
MATERIAL	PROJENGR Kunko	DATE 8/12/77	
FINISH WAVETEK PROCESS	RELEASE APPROV	TOLERANCE UNLESS OTHERWISE SPECIFIED XXX .010 ANGLES 1° XX .030	SCHEMATIC SWEEP & TRANS TIME
DO NOT SCALE DWG	SCALE	MODEL NO. 166	
		CODE IDENT 23338	SHEET 1 OF 1



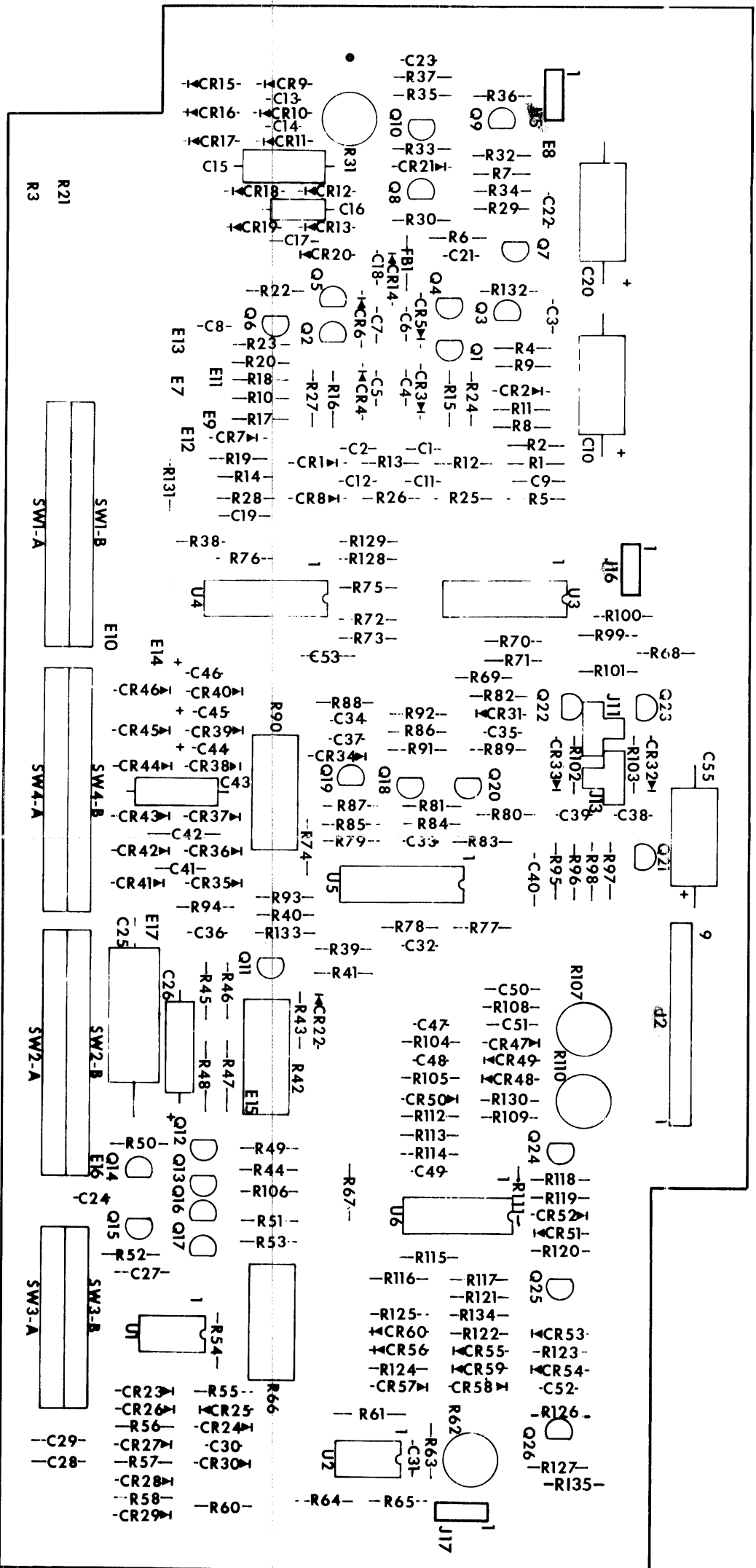

REMOVE ALL BURRS AND BREAK SHARP EDGES MATERIAL		DATE	WAVETEK SAN DIEGO - CALIFORNIA	
DRAWN		PROF	TITLE	
RELEASE APPROV		SCALE	ASSEMBLY	
TOLERANCE UNLESS OTHERWISE SPECIFIED XXX .010 ANGLES 1 XX .030		DO NOT SCALE DWG	SWEEP AND TRANS TIME	
MODEL NO	166	DWG NO	001-00-0629	
CODE	23338	REV	B	
SHEET 1 OF 2				

THIS DOCUMENT CONTAINS PROPRIETARY INFORMATION AND DESIGN RIGHTS BELONGING TO WAVETEK AND MAY NOT BE REPRODUCED FOR ANY REASON EXCEPT CALIBRATION, OPERATION, AND MAINTENANCE WITHOUT WRITTEN AUTHORIZATION.

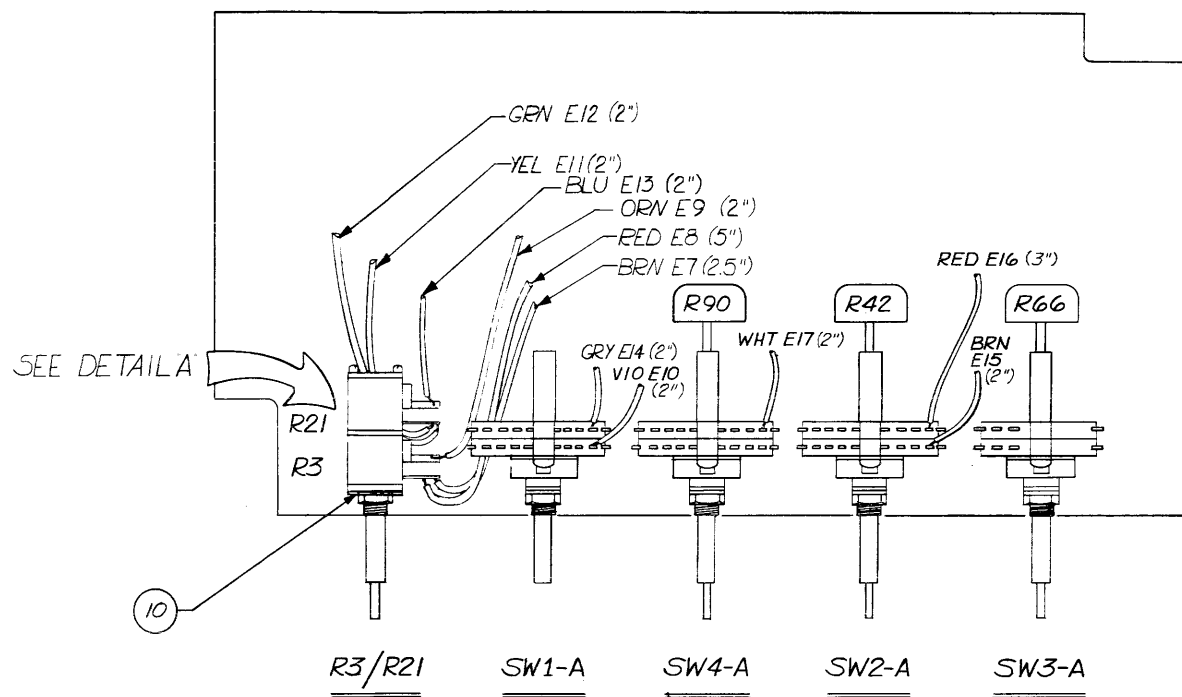
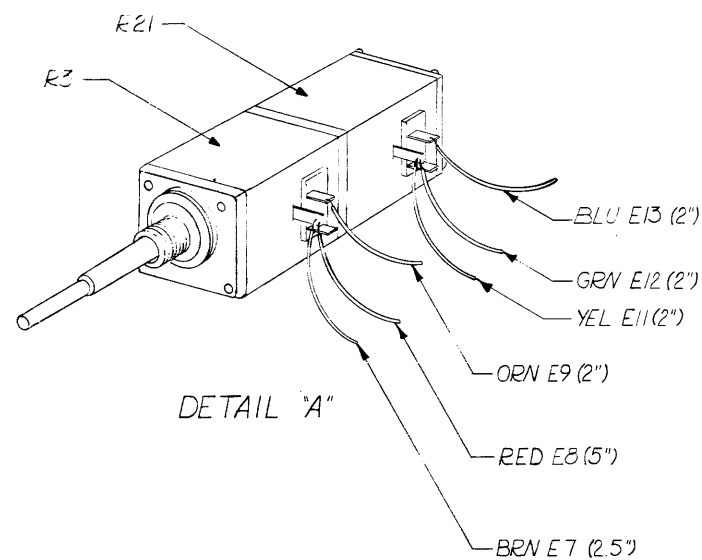

NOTE: UNLESS OTHERWISE SPECIFIED

REMOVE ALL BURRS AND BREAK SHARP EDGES	DRAWN D. COOPER	DATE 4-4-78	WAVETEK <small>SAN DIEGO • CALIFORNIA</small>
MATERIAL	PROVISED <i>Link</i>	RELEASE APPROV <i>Link</i>	
FINISH WAVETEK PROCESS	TOLERANCE UNLESS OTHERWISE SPECIFIED XXX - .010 ANGLES .1 XY - .030		MODEL NO. 166
SCALE	DO NOT SCALE DWG	DWG NO. 0101-00-0629	REV D
	CODE IDENT 23338	SHEET 2 OF 2	

THIS DOCUMENT CONTAINS PROPRIETARY INFORMATION AND DESIGN RIGHTS BELONGING TO WAVETEK AND MAY NOT BE REPRODUCED FOR ANY REASON EXCEPT CALIBRATION, OPERATION, AND MAINTENANCE WITHOUT WRITTEN AUTHORIZATION.

REV ECN BY DATE APP

REFERENCE DESIGNATORS	PART DESCRIPTION	ORIG-MFGR-PART-NO	MFGR	WAVETEK NO.	QTY/PT
NONE	ASSY DWG TRANS TIME	0101-00-0629	WVTK	0101-00-0629	1
NONE	SCHEMATIC TRANS TIME	0103-00-0629	WVTK	0103-00-0629	1
NONE	ASSY SWITCHES SWEEP & TRANS TIME	166-0042	WVTK	1202-00-0042	1
10	BRACKET	1400-00-6923	WVTK	1400-00-6923	1
C21	CAP,CER,100PF,1KV	DD-101	CRL	1500-01-0111	1
C22 C24 C3 C35 C36 C38 C39 C4 C49 C5 C6 C7 C8	CAP,CER,.01MF,50V	CK-103	CRL	1500-01-0310	13
C19 C28 C29 C40 C50 C51 C53 C9	CAP,CER,.1MF,20V	UX20-104	CRL	1500-01-0413	8
C32 C33	CAP,CER,15PF,1KV	DD-150	APCO	1500-01-5011	2
C31 C34 C47 C48	CAP,CER,22PF,1KV	DD-220	ARCO	1500-02-2011	4
C1 C11 C12 C2 C23 C52	CAP,CER,220PF,1KV	DD-221	APCO	1500-02-2111	6
C30	CAP,CER,33PF,1KV	DD-330	APCO	1500-02-2111	1
C37	CAP,CER,68PF,1KV	DD-680	CPL	1500-06-8001	1
C27	CAP,MICA,1000PF,500V	DM19-102F	ARCO	1500-11-0201	1
C18	CAP,MICA,150PF,500V	DM15-151J	ARCO	1500-11-5100	1
C17 C41	CAP,MICA,2000PF,500V	DM19-202J	ARCO	1500-12-0200	2
C10 C20 C55	CAP,ELECT,100MF,16V	500D107C016DC7	SPHAG	1500-31-0101	3
WAVETEK PARTS LIST	TITLE PCA,SWEEP&TRANS TIME	ASSEMBLY NO. 1100-00-0629	REV C	PAGE: 1	

REFERENCE DESIGNATORS	PART DESCRIPTION	ORIG-MFGR-PART-NO	MFGR	WAVETEK NO.	QTY/PT
R31	POT,TRIM,500	91AR500	BECK	4600-05-0104	1
NONE	POT,DUAL,10K,LOG	19M396	AB	4600-21-0303	1
R106 R124 R135 R23 R4 R78 R87	RES,MF,1/8W,1%,100	RN55D-1000F	TRW	4701-03-1000	7
R1 R119 R14 R19 R2 R28 R5 R67	RES,MF,1/8W,1%,1K	RN55D-1001F	TRW	4701-03-1001	8
R114 R123 R125 R127 R41 R45	RES,MF,1/8W,1%,10K	RN55D-1002F	TRW	4701-03-1002	6
R108 R46	RES,MF,1/8W,1%,100K	RN55D-1003F	TRW	4701-03-1003	2
R52 R81 R91	RES,MF,1/8W,1%,10	RN55D-1000F	TRW	4701-03-1009	3
R130	RES,MF,1/8W,1%,12.1K	RN55D-1212F	TRW	4701-03-1212	1
R12 R25 R68	RES,MF,1/8W,1%,150	RN55D-1500F	TRW	4701-03-1500	3
R115 R121 R134 R40	RES,MF,1/8W,1%,1.5K	RN55D-1501F	TRW	4701-03-1501	4
R30 R51	RES,MF,1/8W,1%,15K	RN55D-1502F	TRW	4701-03-1502	2
R101 R32 R33 R6	RES,MF,1/8W,1%,15	RN55D-1500F	TRW	4701-03-1509	4
R96	RES,MF,1/8W,1%,182	RN55D-1820F	TRW	4701-03-1820	1
R102 R103 R29 R53	RES,MF,1/8W,1%,200	RN55D-2000F	TRW	4701-03-2000	4
R113 R116 R118 R120 R44	RES,MF,1/8W,1%,2K	RN55D-2001F	TRW	4701-03-2001	5
WAVETEK PARTS LIST	TITLE PCA,SWEEP&TRANS TIME	ASSEMBLY NO. 1100-00-0629	REV C	PAGE: 3	

REFERENCE DESIGNATORS	PART DESCRIPTION	ORIG-MFGR-PART-NO	MFGR	WAVETEK NO.	QTY/PT
R30 R65	RES,MF,1/8W,1%,619	RA55D-6190F	TRW	4701-03-6190	2
R56 R57 R58	RES,MF,1/8W,1%,6.19K	RN55D-6191F	TRW	4701-03-6191	3
R49	RES,MF,1/8W,1%,61.9	RN55D-6199F	TRW	4701-03-6199	1
R72 R73 R74 R75 R76 R80 R97	RES,MF,1/8W,1%,750	RN55D-7500F	TRW	4701-03-7500	7
R11 R111 R126 R17	RES,MF,1/8W,1%,7.5K	RN55D-7501F	TRW	4701-03-7501	4
R84	RES,MF,1/8W,1%,78.7	RN55D-7877F	TRW	4701-03-7879	1
R122	RES,MF,1/8W,1%,A.25K	RN55D-8251F	TRW	4701-03-8251	1
R82	RES,MF,1/8W,1%,909	RN55D-9090F	TRW	4701-03-9090	1
R47 R61	RES,MF,1/4W,1%,1M	RN60D-1004F	TRW	4701-13-1004	2
CR1 CR31 CR8	DIODE,ZENER 6.2V	1A823A	NPC	4801-01-0823	3
CR14 CR32 CR33 CR34 CR5 CR6	DIODE	FD-777	FAIR	4807-02-0777	6
CR10 CR11 CR12 CR13 CR15 CR16 CR17 CR18 CR19 CR2 CR20 CR21 CR22 CR23 CR24 CR25 CR26 CR27 CR28 CR29 CR3 CR30 CR35 CR36 CR37 CR38 CR39 CR4 CR40 CR41 CR42 CR43 CR44 CR45 CR46 CR47	DIODE	FD-6666	FAIR	4807-02-6666	51
WAVETEK PARTS LIST	TITLE PCA,SWEEP&TRANS TIME	ASSEMBLY NO. 1100-00-0629	REV C	PAGE: 5	

REFERENCE DESIGNATORS	PART DESCRIPTION	ORIG-MFGR-PART-NO	MFGR	WAVETEK NO.	QTY/PT
C25	CAP,POLY,1MF,100V	210-R1C-105F	IMP	1500-41-0504	1
C16 C42	CAP,MYL,102MF,100V	RA1R203F	IMP	1500-42-0304	2
C15 C43	CAP,MYL,102MF,100V	RA1R204F	IMP	1500-42-0404	2
C26	CAP,TANT,10MF,20V	150D106X902042	SPHAG	1500-71-0601	1
C14 C44	CAP,TANT,2.2MF,25V	196D225X9025A1	SPHAG	1500-72-2502	2
C13 C45	CAP,TANT,22MF,15V	196D226X9015A1	SPHAG	1500-72-2601	2
C46	CAP,TANT,220MF,10V	196D227X9010F4	SPHAG	1500-72-2701	1
NONE	SWEEP&TRANS TIME BD	1700-00-0629	WVTK	1700-00-0629	1
J2	CONN,9PIN	09-60-1091	MOLEX	2100-02-0052	1
J15 J16 J17	3 POS HEADER	87348-3	AMP	2100-03-0036	3
J11 J13	SPRING SOCKET	3-330-808-9	AMP	2100-03-0037	2
NONE	COAX SOCKET	226287-2	AMP	2100-03-0038	2
NONE	CABLE CONTACT	226286-2	AMP	2100-03-0040	2
NONE	TRANSIPAD	10160	METRS	2800-11-0004	1
F81	FERRITE BEAD	56-590-65/3B	FERRX	3100-00-0001	1
R110	POT,TRIM,1K	91AR1K	BECK	4600-01-0209	1
R107 R62	POT,TRIM,100K	91AR100K	BECK	4600-01-0402	2
WAVETEK PARTS LIST	TITLE PCA,SWEEP&TRANS TIME	ASSEMBLY NO. 1100-00-0629	REV C	PAGE: 2	

REFERENCE DESIGNATORS	PART DESCRIPTION	ORIG-MFGR-PART-NO	MFGR	WAVETEK NO.	QTY/PT
R13 R26	RES,MF,1/8W,1%,249	RN55D-2490F	TRW	4701-03-2490	2
R10 R20 R64	RES,MF,1/8W,1%,2.49K	RN55D-2491F	TRW	4701-03-2491	3
R94	RES,MF,1/8W,1%,301	RN55D-3010F	TRW	4701-03-3010	1
R71	RES,MF,1/8W,1%,3.01K	RN55D-3011F	TRW	4701-03-3011	1
R109	RES,MF,1/8W,1%,301K	RN55D-3013F	TRW	4701-03-3013	1
R100 R83 R85 R99	RES,MF,1/8W,1%,316	RN55D-3160F	TRW	4701-03-3160	4
R43 R95	RES,MF,1/8W,1%,332	RN55D-3320F	TRW	4701-03-3320	2
R50	RES,MF,1/8W,1%,3.32K	RN55D-3321F	TRW	4701-03-3321	1
R132 R15 R16 R18 R22 R24 R27 R35 R36 R86 R89 R9 R93 R98	RES,MF,1/8W,1%,33.2	RN55D-3322F	TRW	4701-03-3329	14
R69	RES,MF,1/8W,1%,3.65K	RN55D-3651F	TRW	4701-03-3651	1
R38	RES,MF,1/8W,1%,392	RN55D-3920F	TRW	4701-03-3920	1
R37 R7	RES,MF,1/8W,1%,46.4	RN55D-4640F	TRW	4701-03-4649	2
R112 R117 R128 R129 R34 R54 R63 R70 R77 R79 R92	RES,MF,1/8W,1%,499	RN55D-4990F	TRW	4701-03-4990	11
R104 R105 R131 R133 R55 R60 R8	RES,MF,1/8W,1%,4.99K	RN55D-4991F	TRW	4701-03-4991	7
R88	RES,MF,1/8W,1%,51.1	RN55D-5111F	TRW	4701-03-5119	1
WAVETEK PARTS LIST	TITLE PCA,SWEEP&TRANS TIME	ASSEMBLY NO. 1100-00-0629	REV C	PAGE: 4	

REFERENCE DESIGNATORS	PART DESCRIPTION	ORIG-MFGR-PART-NO	MFGR	WAVETEK NO.	QTY/PT
CR48 CR49 CR50 CR51 CR52 CR53 CR54 CR55 CR56 CR57 CR58 CR59 CR60 CR7 CR9					
Q2 Q5	TRANS	2N2369A	MOT	4901-02-3691	2
Q21	TRANS	2N2905A	NSC	4901-02-9051	1
Q10 Q14 Q15 Q17 Q18 Q24 Q25 Q3 Q9	TRANS	2N3640	FAIR	4901-03-6400	9
Q11 Q12 Q13 Q16 Q19 Q20 Q26 Q6	TRANS	2N3646	NSC	4901-03-6460	8
Q1 Q22 Q23 Q4	TRANS	MPS-L08	FAIR	4902-00-0080	4
Q7 Q8	TRANS,M/PR,2N5485 QTY:2:4901-05-4A50	142-501-53	WVTK	4998-00-0009	1
U2	IC	LM 301AN	NSC	7000-03-0100	1
U1	IC,OP-AMP	LF356N	NSC	7000-03-5600	1
U6	IC	CA-3054	RCA	7000-30-5400	1
U4	IC	MC10102	MOT	8001-01-0200	1
U5	IC	MC10105	MOT	8001-01-0500	1
U3	IC	MC10116P	MOT	8001-01-1600	1
WAVETEK PARTS LIST	TITLE PCA,SWEEP&TRANS TIME	ASSEMBLY NO. 1100-00-0629	REV C	PAGE: 6	

REMOVE ALL BURRS AND BREAK SHARP EDGES MATERIAL FINISH WAVETEK PROCESS	DRAWN _____ DATE _____ PROJECT _____ RELEASE APPROV _____	WAVETEK SAN DIEGO • CALIFORNIA TITLE SWEEP & TRANSITION TIME ASSY TOLERANCE UNLESS OTHERWISE SPECIFIED XXX ±.010 ANGLES: 1° XX ±.030 DO NOT SCALE DWG SCALE _____ MODEL NO. 166 DWG NO. 1100-00-0629 REV C CODE IDENT 23338 SHEET 1 OF 1
	NOTE: UNLESS OTHERWISE SPECIFIED	
	© BISHOP GRAPHICS/ACCUPRESS REORDER NO. A-3894	
	8 7 6 5 4 3 2 1	

8

7

6

5

↓

4

3

2

1

REV	ECN	BY	DATE	APP
-----	-----	----	------	-----

THIS DOCUMENT CONTAINS PROPRIETARY INFORMATION AND DESIGN RIGHTS BELONGING TO WAVETEK AND MAY NOT BE REPRODUCED FOR ANY REASON EXCEPT CALIBRATION, OPERATION, AND MAINTENANCE WITHOUT WRITTEN AUTHORIZATION.

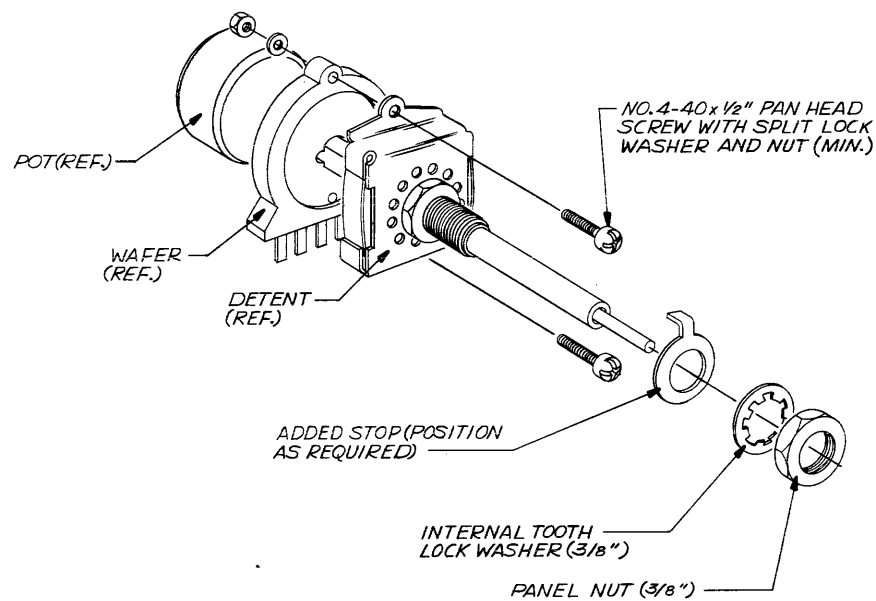

TYPICAL HARDWARE STACK-UP

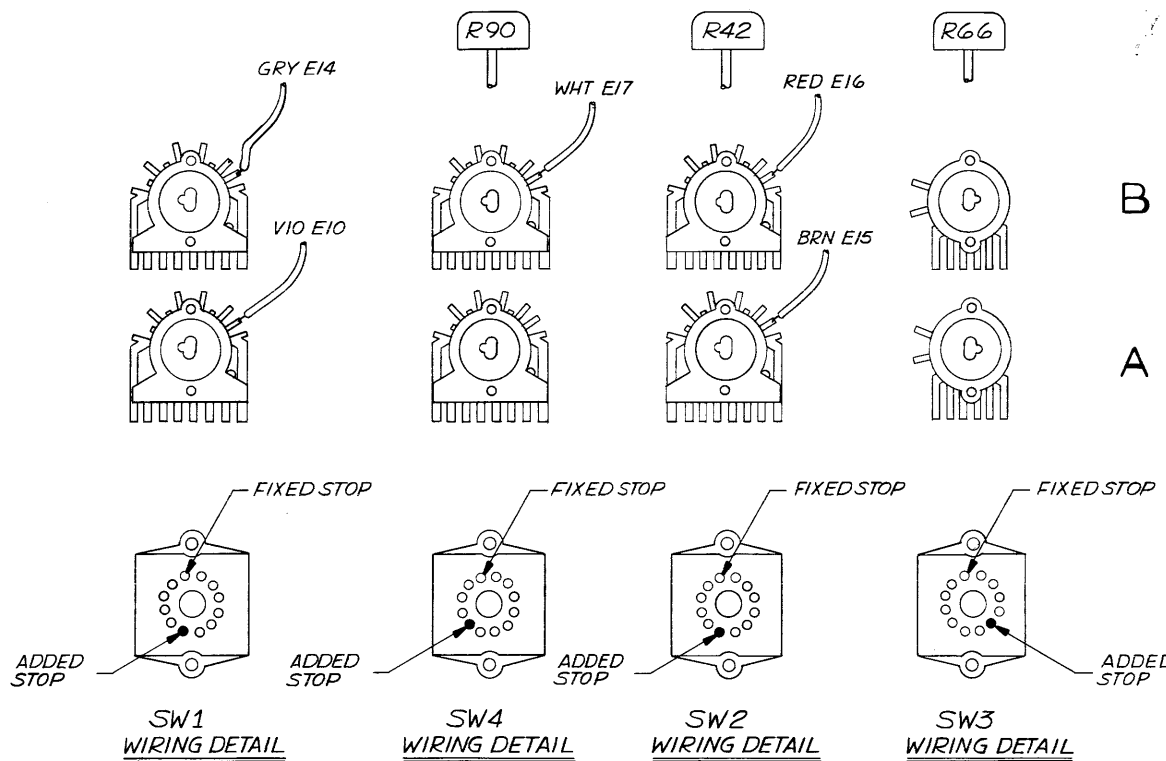

NOTE: ALL DETENTS SHOWN FROM FRONT VIEW IN FULL COUNTER CLOCKWISE POSITION

NOTE: UNLESS OTHERWISE SPECIFIED

REMOVE ALL BURRS AND BREAK SHARP EDGES	DRAWN D. COOPER	DATE 4-5-78	WAVETEK SAN DIEGO • CALIFORNIA
MATERIAL	PROJENGE 1166	RELEASE APPROV	
FINISH WAVETEK PROCESS	TOLERANCE UNLESS OTHERWISE SPECIFIED XXX - .010 ANGLES - 1 XX - .030		MODEL NO. 166
	DO NOT SCALE DWG		DWG NO. 1202-00-0042
	SCALE		REV. 1 OF 2
	CODE IDENT 23338	SHEET	

8

7

6

5

↑

4

3

2

1

THIS DOCUMENT CONTAINS PROPRIETARY INFORMATION AND DESIGN RIGHTS BELONGING TO WAVETEK AND MAY NOT BE REPRODUCED FOR ANY REASON EXCEPT CALIBRATION, OPERATION, AND MAINTENANCE WITHOUT WRITTEN AUTHORIZATION.

REV	ECN	BY	DATE	APP
A	ADDED CONV FROM R7 TO C2	TLF	1/1/77	
C	ECN 1790	RO	8-6-78	

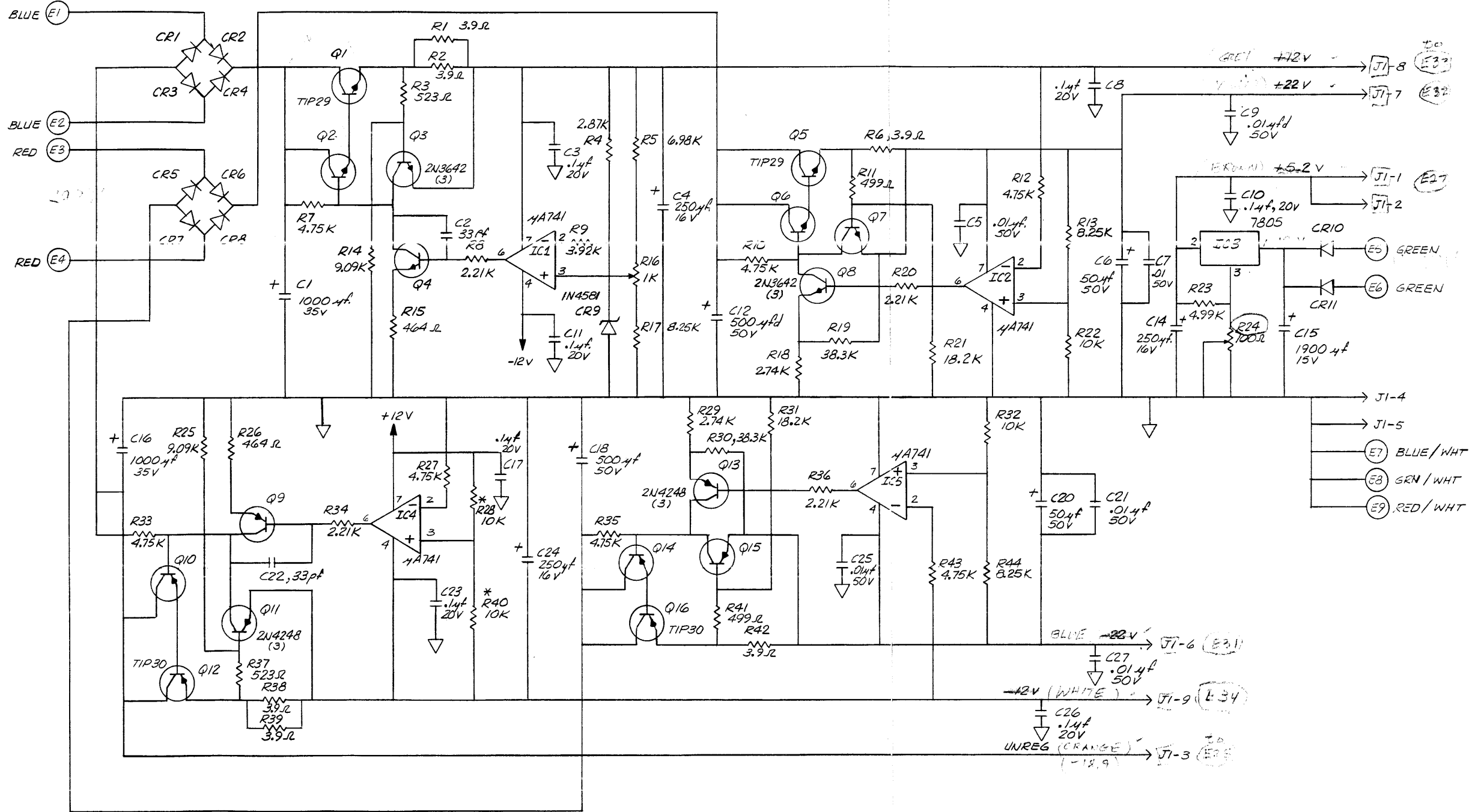

LAST USED: C27, CR11, Q16, R44

UNUSED: C13, C19

4. COLORED CALLOUTS INDICATE TRANSFORMER LEADS.
3. SEE CHASSIS SCHEMATIC FOR INTERWIRING.
2. DIODES ARE SCE-1.
1. * INDICATES MATCHED PAIR.

NOTE: UNLESS OTHERWISE SPECIFIED

REMOVE ALL BURRS AND BREAK SHARP EDGES	DRAWN T. FOSTER	DATE 8-9-77	WAVETEK SAN DIEGO • CALIFORNIA
MATERIAL	PROJ ENGR K. FOSTER	DATE 1/1/77	
FINISH WAVETEK PROCESS	RELEASE APPROV	TOLERANCE UNLESS OTHERWISE SPECIFIED XXX - 010 ANGLES - 1 XX - 030	TITLE SCHEMATIC - POWER SUPPLY
DO NOT SCALE DWG	SCALE	MODEL NO 166	DWG NO 0103-00-0645
CODE IDENT 23338	SHEET 1	REV C	OF 1

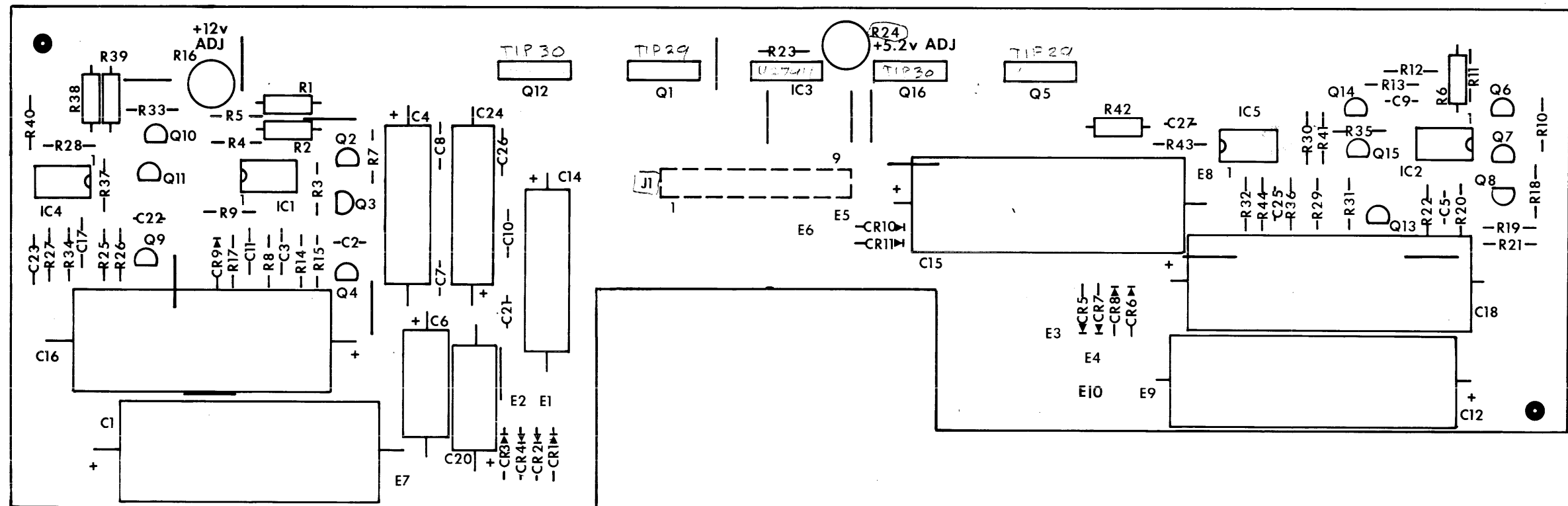

REMOVE ALL BURRS AND BREAK SHARP EDGES	DRAWN	DATE	WAVETEK SAN DIEGO • CALIFORNIA	
MATERIAL	PROJ ENGR	TITLE		
FINISH WAVETEK PROCESS	RELEASE	APPROV	ASSEMBLY POWER SUPPLY	
	TOLERANCE UNLESS OTHERWISE SPECIFIED XXX 010 ANGLES 1 XX 030			
	DO NOT SCALE DWG	MODEL NO	DWG NO	REV
SCALE	166	0101-00-0645	B	
	CODE IDENT 23338	SHEET 1 OF 1		

THIS DOCUMENT CONTAINS PROPRIETARY INFORMATION AND DESIGN RIGHTS BELONGING TO WAVETEK AND MAY NOT BE REPRODUCED FOR ANY REASON EXCEPT CALIBRATION, OPERATION, AND MAINTENANCE WITHOUT WRITTEN AUTHORIZATION.

REV ECN BY DATE APP

REFERENCE DESIGNATORS	PART DESCRIPTION	ORIG-MFGR-PART-NO	MFGR	WAVETEK NO.	QTY/PT
NONE	ASSY DWG POWER SUP.	0101-00-0645	WVTK	0101-00-0645	1
NONE	SCHEMATIC POWER SUP.	0103-00-0645	WVTK	0103-00-0645	1
NONE	REAR PANEL ASSY	166-0648	WVTK	1206-00-0648	1
C21 C25 C27 C5 C7 C9	CAP,CER,.01MF,50V	CK-103	CRL	1500-01-0310	6
C10 C11 C17 C23 C26 C3 C8	CAP,CER,.1MF,20V	UK20-104	ARCO	1500-01-0413	7
C2 C22	CAP,CER,33PF,1KV	DD-330	CHL	1500-03-3011	2
C1 C16	CAP,ELECT,1000MF,35V	39D108G035GL6	SPRAG	1500-31-0212	2
C15	CAP,ELECT,1900MF,15V	39D198G015GL4	SPRAG	1500-31-9201	1
C14 C24 C4	CAP,ELECT,250MF,16V	500D257G016DF7	SPRAG	1500-32-5101	3
C20 C1	CAP,ELECT,50MF,50V	500D501G050DF7	SPRAG	1500-32-0001	2
C12 C18	CAP,ELECT,50MF,50V	39D507G050GL4	SPRAG	1500-35-0103	2
NONE	POWER SUPPLY	1700-00-0645	WVTK	1700-00-0645	1
J1	CONN,9PIN	09-60-1091	MOLEX	2100-02-0052	1
R24	POT,TRIM,100	91AR100	BECK	4600-01-0103	1
R16	POT,TRIM,1K	91AR1K	BECK	4600-01-0209	1
W1 W2 R38 P39 R42 R6	RES,C,1/2W,5%,3.9	HC20GF-3R9	STKPL	4700-25-0399	6
R22 R32	RES,MF,1/8W,1%,10K	RN550-1002F	TRW	4701-03-1002	2

WAVETEK
PARTS LIST

TITLE
PCA,POWER SUPPLY

ASSEMBLY NO.
1101-00-0645
PAGE: 1

REV
A

REFERENCE DESIGNATORS	PART DESCRIPTION	ORIG-MFGR-PART-NO	MFGR	WAVETEK NO.	QTY/PT
CR1 CR10 CR11 CR2 CR3 CR4 CR5 CR6 CR7 CR8	DIODE	SCE-1	SEMTC	4801-02-0001	10
Q2 Q3 Q4 Q6 Q7 Q8	TRANS	2N3642	FAIR	4901-03-6420	6
Q10 Q11 Q13 Q14 Q15 Q9	TRANS	2N424F	FAIR	4901-04-2480	6
Q1 Q5	TRANS	TIP-29	TI	4902-00-0290	2
Q12 Q16	TRANS	TIP-30	TI	4902-00-0300	2
IC1 IC2 IC4 IC5	IC	MA-741	FAIR	7000-07-4100	4
IC3	VOLTAGE REGULATOR	7805393	FAIR	8000-78-0500	1

WAVETEK
PARTS LIST

TITLE
PCA,POWER SUPPLY

ASSEMBLY NO.
1100-00-0645
PAGE: 3

REV
A

REFERENCE DESIGNATORS	PART DESCRIPTION	ORIG-MFGR-PART-NO	MFGR	WAVETEK NO.	QTY/PT
R21 R31	RES,MF,1/8W,1%,18.2K	RN550-1822F	TRW	4701-03-1822	2
R20 R34 R36 R8	RES,MF,1/8W,1%,2.21K	RN550-2211F	TRW	4701-03-2211	4
R18 R29	RES,MF,1/8W,1%,2.74K	RN550-2741F	TRW	4701-03-2741	2
R4	RES,MF,1/8W,1%,2.87K	RN550-2871F	TRW	4701-03-2871	1
R19 R30	RES,MF,1/8W,1%,38.3K	RN550-3832F	TRW	4701-03-3832	2
R9	RES,MF,1/8W,1%,3.92K	RN550-3921F	TRW	4701-03-3921	1
R15 R26	RES,MF,1/8W,1%,464	RN550-4640F	TRW	4701-03-4640	2
R10 R12 R27 R33 R35 R43 R7	RES,MF,1/8W,1%,4.75K	RN550-4751F	TRW	4701-03-4751	7
R11 R41	RES,MF,1/8,1%,499	RN550-4990F	TRW	4701-03-4990	2
R23	RES,MF,1/8W,1%,4.99K	RN550-4991F	TRW	4701-03-4991	1
R3 K37	RES,MF,1/8W,1%,523	RN550-5230F	TRW	4701-03-5230	2
R5	RES,MF,1/8W,1%,6.98K	RN550-6981F	TRW	4701-03-6981	1
R13 R17 R44	RES,MF,1/8W,1%,8.25K	RN550-8251F	TRW	4701-03-8251	3
R14 R25	RES,MF,1/8W,1%,9.09K	RN550-9091F	TRW	4701-03-9091	2
R28 R40	RES,SET,2-10K,1/8W QTY:2:4701-03-1002	142-501-644	WVTK	4789-00-0019	1
CR9	DIODE	1N4581	MICRO	4801-01-4581	1

WAVETEK
PARTS LIST

TITLE
PCA,POWER SUPPLY

ASSEMBLY NO.
1101-00-0645
PAGE: 2

REV
A

REMOVE ALL BURRS AND BREAK SHARP EDGES	DRAWN	DATE	<p>WAVETEK SAN DIEGO • CALIFORNIA</p> <p>TITLE POWER SUPPLY</p>
MATERIAL	PROJ ENGR	RELEASE APPROV	
FINISH WAVETEK PROCESS	TOLERANCE UNLESS OTHERWISE SPECIFIED XXX - 010 ANGLES - 1 XX - 030		DO NOT SCALE DWG
SCALE		MODEL NO. 168	DWG NO. 1100-00-0645
		CODE IDENT 23338	REV A

NOTE: UNLESS OTHERWISE SPECIFIED

8

7

6

5

↓

4

3

2

1

REV ECN BY DATE APP

THIS DOCUMENT CONTAINS PROPRIETARY INFORMATION AND DESIGN RIGHTS BELONGING TO WAVETEK AND MAY NOT BE REPRODUCED FOR ANY REASON EXCEPT CALIBRATION, OPERATION, AND MAINTENANCE WITHOUT WRITTEN AUTHORIZATION.

D

C

B

A

REFERENCE DESIGNATORS	PART DESCRIPTION	ORIG-MFGR-PART-NO	MFGR	WAVETEK NO.	QTY/PT
NONE	ASSY DRWG REAR PANEL	0102-00-0648	WVTK	0102-00-0648	1
T1	TRANSFORMER	166-0020	WVTK	1204-00-0020	1
NONE	INSULATOR	147-367	WVTK	1400-00-3700	1
1	BAR, CLAMP	147-379	WVTK	1400-00-3733	1
2	STRIP, COMP REF:3200-08-0001	162-312	WVTK	1400-00-3840	1
13	LABEL, WARNING	1400-00-6940	WVTK	1400-00-6940	1
3	MNTG PLATE, CORCOM	1400-00-8132	WVTK	1400-00-8132	1
7	COVER, CORCOM	1400-00-8140	WVTK	1400-00-8140	1
5	CASTING, REAR, MOD FROM:1400-00-3671	1400-00-8159	WVTK	1400-00-8159	1
14	INSULATOR, PWR SWITCH REF:1600-99-0001	1400-00-8370	WVTK	1400-00-8370	1
4	I.D. LABEL	1400-00-9090	WVTK	1400-00-9090	1
6	RECEPTACLE	6J1	CORCM	2100-03-0026	1
9	SOLDER LUG	1485-6	SMITH	2100-04-0025	3
8	FUSE, 250V, 1/2A, SB	313-500	LITFU	2400-05-0010	1
10	SPEEDNUT, TYPE "U"	C12050-632-4	TJNN	2800-09-0002	4
11	SWITCH ASSY PB	5103-00-0020	WVTK	5102-00-0005	1

WAVETEK PARTS LIST	TITLE REAR PANEL ASSY	ASSEMBLY NO. 1206-00-0648	REV B
PAGE: 1			

REFERENCE DESIGNATORS	PART DESCRIPTION	ORIG-MFGR-PART-NO	MFGR	WAVETEK NO.	QTY/PT
12	PWR CORD	0-7788-008-GY	PACRD	6001-80-0005	1

WAVETEK PARTS LIST	TITLE REAR PANEL ASSY	ASSEMBLY NO. 1206-00-0648	REV B
PAGE: 2			

REMOVE ALL BURRS AND BREAK SHARP EDGES	DRAWN	DATE	WAVETEK SAN DIEGO • CALIFORNIA
MATERIAL	PROJ ENGR		
FINISH WAVETEK PROCESS	RELEASE APPROV		REAR PANEL
	TOLERANCE UNLESS OTHERWISE SPECIFIED XX: .010 ANGLES: 1:1 XX: .030		
	DO NOT SCALE DWG		
SCALE	MODEL NO. 166	DWG NO. 1206-00-06-13	REV B
	CODE IDENT 23338	SHEET	OF

NOTE: UNLESS OTHERWISE SPECIFIED

8

7

6

5

↑

4

3

2

1

REV	ECN	BY	DATE	APP
B	ECN 1790	RD	8/16/78	
C	ECN 1879		12/13/79	

XFORMER CHART	
WIRE COLOR	P.C. BD.
BLU	E1
BLU	E2
BLU/WHT	E7
GRN	E5
GRN	E6
RED	E4
RED	E3
GRN/WHT	E8
RED/WHT	E9

THIS DOCUMENT CONTAINS PROPRIETARY INFORMATION AND DESIGN RIGHTS BELONGING TO WAVETEK AND MAY NOT BE REPRODUCED FOR ANY REASON EXCEPT CALIBRATION, OPERATION, AND MAINTENANCE WITHOUT WRITTEN AUTHORIZATION.

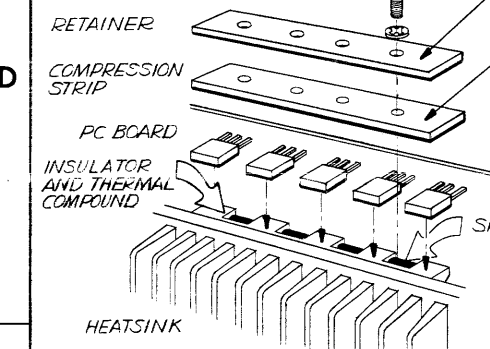

SELF RETAIN SPEEDNUT P/N 2800-00-0003 (4) USED TO RETAIN "TIPS" ON PC BD. TO HEATSINK REAR PANEL

NOTE: WIRES TO THESE LUGS MUST MAKE MECHANICAL CONNECTION BEFORE SOLDER.
#18 GRN/YEL TO CHASSIS AND GENIYEL FROM AFFMR GO ON TOP 2 LUGS.
GENIYEL #18GA GOES TO BOTTOM LUG FROM CORCOM.

FOR CORCOM INSTALLATION SEE DETAIL "A"

TO P.C. BOARD (SEE XFORMER CHART)

TO CORCOM

GRN/YEL TO REAR PANEL



FISH PAPER INSTALL BEFORE SLEEVING

NO. 4-40x1/2" PAN HEAD SCREW (BLACK) WITH FLAT WASHER, INT. TOOTH LOCK WASHER AND NUT (2)

NO. 6-32x1/2" PAN HEAD SCREW (2) WITH SPLIT LOCK WASHER, GND. LUGS (3) AND LOCKING NUT (2) (USE TWO LUGS ON TOP SCREW.)

NO. 8-32x2 1/4" PAN HEAD SCREW (BLACK) WITH INT. TOOTH LOCK WASHER AND NUT (4)

DETAIL "A" CORCOM INSTALLATION AND WIRING

CORCOM FUSE
100 } = 500 MAT SB
120 }
220 } = 250 MAT SB
240 }

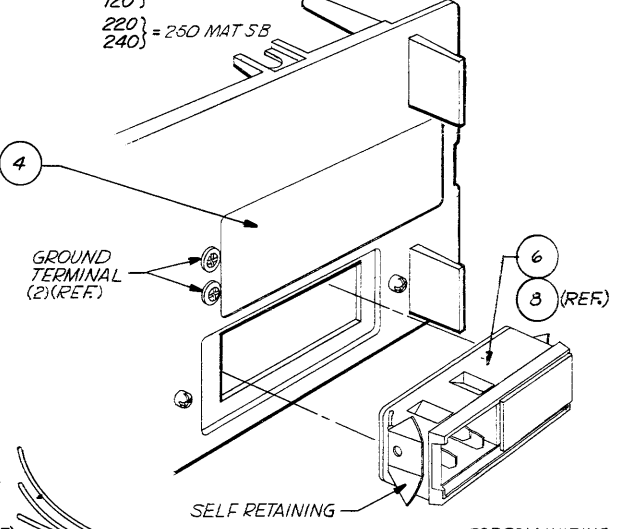

BLK(C)
GRY(D)
ORN(A)
BLK/WHT(E)
GRY/WHT(F)

WIRING FROM XFORMER

WHT }
BLU } 22 GA.
RED }
BRN }

18 GA. TO GND. TERM (REAR PANEL)

TO POWER SWITCH

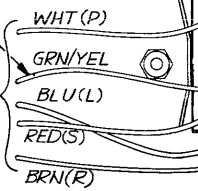

WHT(P)

GRN/YEL

BLU(L)

RED(S)

BRN(R)

GND

N

W

F

E

D

C

B

A

JUMPER B TO H WHT

DETAIL "B" POWER SWITCH INSTALLATION

NO. 2-56x3/8" PAN HEAD SCREW WITH MIN. INT. TOOTH LOCK WASHER AND NUT (2)

NO. 6-32x3/8" PAN HEAD SCREW (SELF-TAP) WITH INT. TOOTH LOCK WASHER (4)

NOTE: UNLESS OTHERWISE SPECIFIED

REMOVE ALL BURRS AND BREAK SHARP EDGES	DRAWN D. COOPER	DATE 10/3/77	WAVETEK SAN DIEGO • CALIFORNIA
MATERIAL	PROJ ENGR	166	
FINISH WAVETEK PROCESS	RELEASE APPROV	TOLERANCE UNLESS OTHERWISE SPECIFIED XXX ±.010 ANGLES -1° XX ±.030	TITLE ASSEMBLY REAR PANEL
SCALE	DO NOT SCALE DWG	MODEL NO. 166	
		DWG NO. 0102-00-0648	REV C
		CODE IDENT 23338	SHEET 1 OF 1