

Errata

Title & Document Type: 6209B Operating & Service Manual

Manual Part Number: 06209-90003

Revision Date: June 1969

HP References in this Manual

This manual may contain references to HP or Hewlett-Packard. Please note that Hewlett-Packard's former test and measurement, semiconductor products and chemical analysis businesses are now part of Agilent Technologies. We have made no changes to this manual copy. The HP XXXX referred to in this document is now the Agilent XXXX. For example, model number HP8648A is now model number Agilent 8648A.

About this Manual

We've added this manual to the Agilent website in an effort to help you support your product. This manual provides the best information we could find. It may be incomplete or contain dated information, and the scan quality may not be ideal. If we find a better copy in the future, we will add it to the Agilent website.

Support for Your Product

Agilent no longer sells or supports this product. You will find any other available product information on the Agilent Test & Measurement website:

www.tm.agilent.com

Search for the model number of this product, and the resulting product page will guide you to any available information. Our service centers may be able to perform calibration if no repair parts are needed, but no other support from Agilent is available.



HEWLETT
PACKARD

DC Power Supply
Lab Series
Model 6209B

OTS LIBRARY

AAIG

MANUAL CHANGES
Model 6209B DC Power Supply
Manual HP P/N 06209-90003
5/2/89

Make all corrections in the manual according to errata below, then check the following table for your power supply serial number and enter any listed changes(s) in the manual.

SERIAL		MAKE CHANGES
Prefix	Number	
All	---	Errata
7F	1467-1606	1
7F	1607-1816	1,2
1147A	1817-1866	1,2,3
1147A	1867-2166	1-4
1147A	2167-2816	1-5
1147A	2817-3066	1-6
1527A	3067-3916	1-7
1721A	3917-4936	1-8
1930A	4937-5596	1-9
2042A	5597-6471	1-10
2230A	6472-6521	1-11
2239A	6552-6751	1-12
2323A	6752-6991	1-13
2403A	6992-7021	1-14
2409A	7022-7231	1-15
2446A	7232-8521	1-16
2446A	8522-8541	1-17
2838A	8542-up	1-17

ERRATA:

In the replaceable parts table make the following change: R38: Change from "selected" resistor to nominal value 30 k, 1/2 W, A.B., HP P/N 0686-3035.

On page 3-5, delete the bottom half of Figure 3-9 (Auto-Series, Three Units). Note that the supply should not be operated at more than 300 volts above ground.

CHANGE 1:

In the replaceable parts table, make the following change: Terminal Strip: Add, HP P/N 0360-0401.

ERRATA:

On the title page, change the HP P/N of the manual to 06209-90003. Page 5-8, paragraph 5-46, Step g: Change "66mVdc" to "3mVdc". Page 5-8, paragraph 5-48, Step i: Change "66mVdc" to "3mVdc".

In the replaceable parts list change CR26-29: Change to HP P/N 1901-0330. Add C26, fxd elect., 20uf, +75-10%, 16VDC, HP P/N 0180-0300.

CHANGE 2:

In the replaceable parts table, change power transformer T1 to HP P/N 5080-7183.

CHANGE 3:

The Serial Prefix of this unit has been changed to 1147A. This is the only change.

CHANGE 4:

The standard colors for this instrument are now mint gray (for front panel) and olive gray (for all other external surfaces). Option X95 designates use of the former color scheme of light gray and blue gray. Option A85 designates use of a light gray front panel with olive gray used for all other external surfaces. New part numbers are shown on next page.

ERRATA:

Change the last line of paragraph 5-28 to read: "which is 100 mA." Change the component values in the contact protection network in Figure 5-6 to .001 uF and 450 ohms.

In the parts list, change HP P/N of rubber bumper (qty 4) to 0403-0002.

In Table 1-1, change the INTERNAL IMPEDANCE AS A CONSTANT VOLTAGE SOURCE (Output Impedance) specification to read as follows: Output Impedance specification to read as follows: Output Impedance (Typical): Approximated by a 20 milliohm resistance in series with a 1 microhenry inductance.

CHANGE 5:

Change R49 to 30 k, 10 W, HP P/N 0811-1918.

CHANGE 6:

In the parts list and on schematic diagram, make the following changes: R14: Change to 6.8 ohms, +/-5%, 1/2 W, 0698-5525. R15: Change to 150 k, +/-5%, 2 W, 0764-0049.

NOTE: Four instruments from a previous run have CHANGE 6 incorporated. The serial numbers are: 1147A-02793, 02795, 02796, and 02797.

CALL CENTER LIBRARY



2400013143

DESCRIPTION	HP PART NO.		
	STANDARD	OPTION A85	OPTION X95
Front Panel Lettered	06209-60003	06209-60001	<-----
Heat Sink Rear	5020-8063	<-----	5020-5566
Chassis, Right Side	5060-7956	<-----	5060-6118
Chassis, Left Side	5060-7955	<-----	5060-6119
Cover, Top	5000-9424	<-----	5000-6061

The front panel binding posts have been changed to a type with better designed insulation. Delete the two types of posts listed on page 6-8 of the parts list and add: black binding post, HP P/N 1510-0114 (qty 2); and red binding post HP P/N 1510-0115 (qty 1).

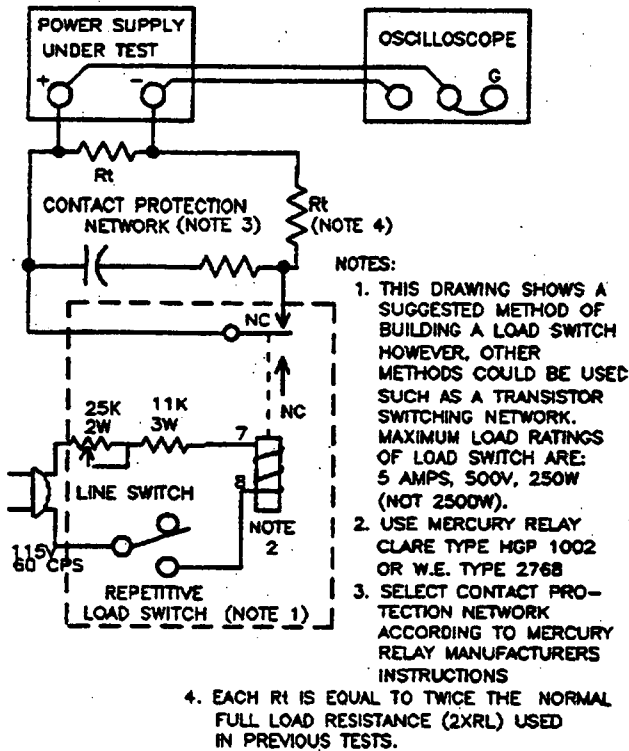

CHANGE 7:

Change the Transient Recovery Time specification Table 1-1 to read: "Less than 50 u sec for output recovery to within 10 mV of nominal output voltage following a load change from full load to half load (or vice versa)." Also change the last line of paragraph 5-28 to read: "which is 50 mA." Figure 5-6 must also be corrected as shown on next page.

ERRATA:

Effective January 1st, 1977, Option 008 (10-turn kcurrent control) has been redesignated Option 009. Also, Options 013 (decadial for voltage control) and 014 (10-turn current control with decadal) are no longer available individually, but they are available combined into a single new option designated Option 015. Make these changes wherever Option 008, 013, or 014 is mentioned in the manual.

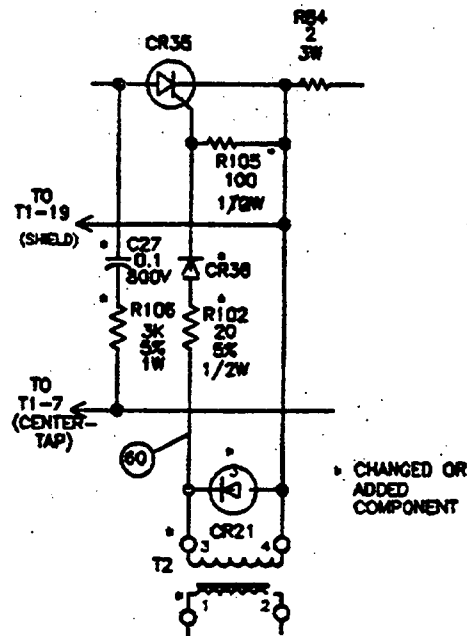

Preregulator Circuit, part of Change 8

Change the part number of pilot light DS1 to 1450-0566. This new light is more reliable than the former one.

The blue-gray meter bezel has been replaced by a black one, HP P/N 4040-0414.

The corrugated shipping carton for this model has been changed to HP P/N 9211-2570. Two 9220-2703 floater pads are used.

CHANGE 8:

The preregulator circuit has been revised to eliminate turn-on overshoot. The revised portion of the circuit is shown in the next column. The required parts list changes are as follows: (a) Change R102 to 20 ohms, 5%, 1/2 W, HP P/N 0686-2005; (b) Add R105, 100 ohms, 5%, 1/2 W, 0686-1015; (c) Add R106, 3 k, 5%, 1 W, 0689-3025; (d) Add C27, 0.01 uF, 800 V, 0160-4569; (e) Change CR21 to HP P/N 1901-0460; (f) Add CR36, HP P/N 1901-0033.

ERRATA:

For all instruments delivered on or after July 1, 1978, change the HP P/N for fuseholder from 1400-0084 to fuseholder body 2110-0564 and fuseholder carrier 2110-0565. Change the HP P/N for fuseholder nut from 2950-0038 to 2110-0569. If old fuseholder must be replaced for any reason, replace complete fuseholder and nut with new fuseholder parts. Do not replace new parts with old parts.

On page 3-5, Figure 3-9, ground (GND) should be connected to the minus terminal (-), not the plus (+). This applies to both two and three unit diagrams.

CHANGE 9:

In the parts list, change the HP P/N for the binding posts and associated hardware to the following:

Red binding post, qty 2: 1510-0091
Terminal lug, qty 2: 0360-0042
Lockwasher, qty 2: 2190-0056
Nut, qty 2: 2500-0001
Black binding post, qty 1: 1510-0107
Terminal lug, qty 1: 0360-1190
Nut, qty 3: 2950-0144

CHANGE 10:

In the replaceable parts list, change switch S1 to HP P/N 3101-2424. On the Schematic diagram change S1 to show two switch sections, one which breaks the AC Line (as shown), the other breaks the ACC Line.

CHANGE 11:

In the replaceable parts list and on the schematic, change R16 to var. ww 20 k ten-turn HP P/N 2100-1867 qty 1. Also delete: Knob HP P/N 0370-0101 and Knob HP P/N 0370-0179. Add: Knob round HP P/N 0370-0137 qty 1. This change eliminates Option 009 because Option 009 is now standard equipment.

CHANGE 12:

In the replaceable parts list, change R19 to 1 M ohm 1%, 1/8 W, HP P/N 0757-0344 and VR2 to 6.2 V, 2%, HP P/N 1902-0509.

CHANGE 13:

In the replaceable parts list, page 6-5, under L1, add inductor L2, 0.6uh, HP P/N 9170-0894, qty 1. On the schematic L2 is added between the emitter lead of PNP transistor Q10 and the cathode end of CR 32.

CHANGE 14:

In the replaceable parts list, page 6-6, change R41 to 12.1K, 1%, 1/8W HP P/N 0757-0444 and R42 to 6.81K, 1%, 1/8W, HP P/N 0757-0439. Also, change R41 and R42 on the Schematic Diagram, Figure 7-2 to the new values.

ERRATA:

In the replaceable parts list, page 6-8 change Barrier Strip to HP P/N 0360-2185.

CHANGE 15:

In the replaceable parts list, page 6-8, add the following mechanical assembly; Barrier Strip Guard Assembly, HP P/N 5060-2862, TQ 1.

CHANGE 16:

In the replaceable parts list, page 6-7 under Miscellaneous add washer-flat, non-metallic, HP P/N 3050-0003, TQ 1, (ref. T3). This washer is located under the head of the screw attaching T3 to the main board.

ERRATA:

On page 3-3 add the following warning to paragraph 3-22.

WARNING

When the power supply is remote programmed with a voltage source, the programming voltage will appear at the output terminals when the AC input power is turned off. Therefore, do NOT contact the output terminals. The front panel meters will not indicate the presence of this voltage.

ERRATA:

In the replaceable parts list, page 6-7 change VR3 to voltage suppresser, VR=38.10V, BV=42.3V to 51.7V @ IT=1MA, HP P/N 0837-0289, TQ 1.

CHANGE 17:

In the replaceable parts list, and on the schematic, add resistor R107 (10 Meg, 5%, CC, HP P/N 0686-1065). R107 is mechanically installed on pins in the location of C27, and electrically is parallel to C27. (C27 is removed and placed on the pins below R107).

ERRATA:

In the replaceable parts list, change the part number for CR35 from HP P/N 1884-0302 to HP P/N 1884-0338 (qty 1).



**DC POWER SUPPLY
LAB SERIES
MODEL 6209B**

OPERATING AND SERVICE MANUAL

FOR SERIALS 7F1117 - up*

*For Serials Above 7F1117
Check for inclusion of
change page.

*For Serials Below 7F1117
Refer to Appendix A

100 Locust Avenue, Berkeley Heights, New Jersey 07922

TABLE OF CONTENTS

Section	Page No.	Section	Page No.
I GENERAL INFORMATION	1-1	IV PRINCIPLES OF OPERATION (Continued)	
1-1 Description	1-1	4-13 Detailed Circuit Analysis	4-2
1-6 Specifications	1-1	4-14 Preregulator and Control	
1-8 Options	1-1	Circuit	4-2
1-10 Accessories	1-1	4-20 Turn-On Control Circuit	4-4
1-12 Instrument Identification	1-2	4-24 Series Regulator	4-4
1-15 Ordering Additional Manuals	1-2	4-26 Constant Voltage Com-	
II INSTALLATION	2-1	parator Circuit	4-4
2-1 Initial Inspection	2-1	4-32 Constant Current Com-	
2-3 Mechanical Check	2-1	parator Circuit	4-5
2-5 Electrical Check	2-1	4-37 Voltage Clamp Circuit	4-5
2-7 Installation	2-1	4-40 Mixer and Driver Amplifiers	4-5
2-9 Location	2-1	4-43 Reference Circuit	4-5
2-11 Outline Diagram	2-1	4-46 Meter Circuit	4-6
2-13 Rack Mounting	2-1	4-53 Additional Protection	
2-17 Input Power Requirements	2-3	Features	4-7
2-19 Connections for 230 Volt		V MAINTENANCE	5-1
Operation	2-3	5-1 Introduction	5-1
2-21 Power Cable	2-3	5-3 Test Equipment Required	5-1
2-24 Repackaging for Shipment	2-3	5-5 Performance Test	5-2
III OPERATING INSTRUCTIONS	3-1	5-7 Constant Voltage Tests	5-2
3-1 Turn-On Check-Out Procedure	3-1	5-32 Output Impedance	5-6
3-3 Operating Modes	3-1	5-42 Constant Current Tests	5-7
3-5 Normal Operating Mode	3-1	5-51 Troubleshooting	5-9
3-7 Constant Voltage	3-1	5-57 Overall Troubleshooting	
3-9 Constant Current	3-2	Procedure	5-9
3-11 Connecting Load	3-2	5-61 Regulating Loop Troubles	5-10
3-14 Operation Beyond Normal		5-67 Repair and Replacement	5-13
Rated Output	3-2	5-69 Adjustment and Calibration	5-14
3-16 Optional Operating Modes	3-2	5-71 Meter Zero	5-14
3-17 Remote Programming,		5-73 Voltmeter Tracking	5-14
Constant Voltage	3-2	5-75 Ammeter Tracking	5-15
3-25 Remote Programming,		5-77 Constant Voltage Program-	
Constant Current	3-3	ming Current	5-15
3-31 Remote Sensing	3-3	5-80 Constant Current Program-	
3-36 Series Operation	3-4	ming Current	5-15
3-41 Parallel Operation	3-5	5-83 Reference Circuit Adjust-	
3-44 Auto-Tracking Operation	3-6	ments	5-15
3-47 Special Operating Con-		5-85 Constant Voltage Tran-	
siderations	3-6	sient Response	5-16
3-48 Pulse Loading	3-6	5-87 Preregulator Tracking	5-16
3-50 Output Capacitance	3-7	VI REPLACEABLE PARTS	6-1
3-53 Reverse Voltage Loading	3-7	6-1 Introduction	6-1
3-55 Reverse Current Loading	3-7	6-4 Ordering Information	6-1
IV PRINCIPLES OF OPERATION	4-1	APPENDIX A	A-1
4-1 Overall Block Diagram		VII CIRCUIT DIAGRAMS	7-1
Discussion	4-1		

LIST OF TABLES

Table	Page No.
1-1 Specifications	1-3
5-1 Test Equipment Required	5-1
5-2 Reference Circuit Troubleshooting	5-10
5-3 Overall Troubleshooting	5-11
5-4 High Output Voltage Troubleshooting	5-12
5-5 Low Output Voltage Troubleshooting	5-12
5-6 Preregulator/Control Circuit Troubleshooting	5-13
5-7 Selected Semiconductor Characteristics	5-13
5-8 Checks and Adjustments After Replacement of Semiconductor Devices	5-14
6-1 Reference Designators	6-1
6-2 Description Abbreviations	6-1
6-3 Code List of Manufacturers	6-2
6-4 Replaceable Parts	6-5

LIST OF ILLUSTRATIONS

Figure	Page No.	Figure	Page No.
2-1 Outline Diagram	2-1	4-3 SCR Phase Control Over DC Input Level	4-3
2-2 Rack Mounting, Two Units	2-2	4-4 Preregulator Control Circuit Waveforms	4-3
2-3 Rack Mounting, One Unit	2-2	4-5 Voltmeter Connections, Simplified Schematic	4-6
2-4 Primary Connections	2-3	4-6 Ammeter Connections, Simplified Schematic	4-6
3-1 Front Panel Controls and Indicators	3-1	5-1 Differential Voltmeter Substitute, Test Setup	5-2
3-2 Normal Strapping Pattern	3-1	5-2 Front Panel Terminal Connections	5-3
3-3 Remote Resistance Programming (Constant Voltage)	3-2	5-3 Load Regulation, Constant Voltage	5-3
3-4 Remote Voltage Programming (Constant Voltage)	3-3	5-4 Constant Voltage Ripple and Noise, Test Setup	5-4
3-5 Remote Resistance Programming (Constant Current)	3-3	5-5 CV Noise Spike, Test Setup	5-5
3-6 Remote Voltage Programming (Constant Current)	3-3	5-6 Transient Recovery Time, Test Setup	5-6
3-7 Remote Sensing	3-4	5-7 Transient Recovery Time, Waveforms	5-6
3-8 Normal Series	3-4	5-8 Output Impedance, Test Setup	5-6
3-9 Auto-Series, Two and Three Units	3-5	5-9 Output Current Measurement Technique	5-8
3-10 Normal Parallel	3-5	5-10 Output Current, Test Setup	5-8
3-11 Auto-Parallel, Two and Three Units	3-6	5-11 CC Ripple and Noise, Test Setup	5-9
3-12 Auto-Tracking, Two and Three Units	3-6		
4-1 Overall Block Diagram	4-1		
4-2 Operating Locus of a CV/CC Power Supply	4-2		

SAFETY SUMMARY

The following general safety precautions must be observed during all phases of operation, service, and repair of this instrument. Failure to comply with these precautions or with specific warnings elsewhere in this manual violates safety standards of design, manufacture, and intended use of the instrument. Hewlett-Packard Company assumes no liability for the customer's failure to comply with these requirements.

BEFORE APPLYING POWER.

Verify that the product is set to match the available line voltage and the correct fuse is installed.

GROUND THE INSTRUMENT.

This product is a Safety Class 1 instrument (provided with a protective earth terminal). To minimize shock hazard, the instrument chassis and cabinet must be connected to an electrical ground. The instrument must be connected to the ac power supply mains through a three-conductor power cable, with the third wire firmly connected to an electrical ground (safety ground) at the power outlet. For instruments designed to be hard-wired to the ac power lines (supply mains), connect the protective earth terminal to a protective conductor before any other connection is made. Any interruption of the protective (grounding) conductor or disconnection of the protective earth terminal will cause a potential shock hazard that could result in personal injury. If the instrument is to be energized via an external autotransformer for voltage reduction, be certain that the autotransformer common terminal is connected to the neutral (earthed pole) of the ac power lines (supply mains).

INPUT POWER MUST BE SWITCH CONNECTED.

For instruments without a built-in line switch, the input power lines must contain a switch or another adequate means for disconnecting the instrument from the ac power lines (supply mains).

DO NOT OPERATE IN AN EXPLOSIVE ATMOSPHERE.

Do not operate the instrument in the presence of flammable gases or fumes.

KEEP AWAY FROM LIVE CIRCUITS.

Operating personnel must not remove instrument covers. Component replacement and internal adjustments must be made by qualified service personnel. Do not replace components with power cable connected. Under certain conditions, dangerous voltages may exist even with the power cable removed. To avoid injuries, always disconnect power, discharge circuits and remove external voltage sources before touching components.

DO NOT SERVICE OR ADJUST ALONE.

Do not attempt internal service or adjustment unless another person, capable of rendering first aid and resuscitation, is present.

DO NOT EXCEED INPUT RATINGS.

This instrument may be equipped with a line filter to reduce electromagnetic interference and must be connected to a properly grounded receptacle to minimize electric shock hazard. Operation at line voltages or frequencies in excess of those stated on the data plate may cause leakage currents in excess of 5.0 mA peak.

SAFETY SYMBOLS.



Instruction manual symbol: the product will be marked with this symbol when it is necessary for the user to refer to the instruction manual (refer to Table of Contents).



Indicates hazardous voltages.



or



Indicate earth (ground) terminal.

WARNING

The WARNING sign denotes a hazard. It calls attention to a procedure, practice, or the like, which, if not correctly performed or adhered to, could result in personal injury. Do not proceed beyond a WARNING sign until the indicated conditions are fully understood and met.

CAUTION

The CAUTION sign denotes a hazard. It calls attention to an operating procedure, or the like, which, if not correctly performed or adhered to, could result in damage to or destruction of part or all of the product. Do not proceed beyond a CAUTION sign until the indicated conditions are fully understood and met.

DO NOT SUBSTITUTE PARTS OR MODIFY INSTRUMENT.

Because of the danger of introducing additional hazards, do not install substitute parts or perform any unauthorized modification to the instrument. Return the instrument to a Hewlett-Packard Sales and Service Office for service and repair to ensure that safety features are maintained.

Instruments which appear damaged or defective should be made inoperative and secured against unintended operation until they can be repaired by qualified service personnel.

SECTION I GENERAL INFORMATION

1-1 DESCRIPTION

1-2 This power supply (see cover) is completely transistorized and suitable for either bench or rack operation. It is a compact, well-regulated, Constant Voltage/Constant Current supply that will furnish full rated output voltage at the maximum rated output current or can be continuously adjusted throughout the output range. The front panel CURRENT controls can be used to establish the output current limit (overload or short circuit) when the supply is used as a constant voltage source and the VOLTAGE control can be used to establish the voltage limit (ceiling) when the supply is used as a constant current source. The supply will automatically crossover from constant voltage to constant current operation and vice versa if the output current or voltage exceeds these preset limits.

1-3 The power supply has both front and rear terminals. Either the positive or negative output terminal may be grounded or the power supply can be operated floating at up to a maximum of 300 Volts off ground.

1-4 A single meter is used to measure either output voltage or output current in one of two ranges. The voltage or current ranges are selected by a METER switch on the front panel.

1-5 Barrier strip terminals located at the rear of the unit allow ease in adapting to the many operational capabilities of the power supply. A brief description of these capabilities is given below:

a. Remote Programming. The power supply may be programmed from a remote location by means of an external voltage source or resistance.

b. Remote Sensing. The degradation in regulation which would occur at the load because of the voltage drop in the load leads can be reduced by using the power supply in the remote sensing mode of operation.

c. Series and Auto-Series Operation. Power supplies may be used in series when a higher output voltage is required in the voltage mode of operation or when greater voltage compliance is required in the constant current mode of operation. Auto-Series operation permits one knob control of the total output voltage from a "master" supply.

d. Parallel and Auto-Parallel Operation. The power supply may be operated in parallel with a similar unit when greater output current capability is required. Auto-Parallel operation permits one

knob control of the total output current from a "master" supply.

e. Auto-Tracking. The power supply may be used as a "master" supply, having control over one (or more) "slave" supplies that furnish various voltages for a system.

1-6 SPECIFICATIONS

1-7 Detailed specifications for the power supply are given in Table 1-1.

1-8 OPTIONS

1-9 Options are factory modifications of a standard instrument that are requested by the customer. The following options are available for the instrument covered by this manual. Where necessary, detailed coverage of the options is included throughout the manual.

<u>Option No.</u>	<u>Description</u>
08	<u>Current 10-Turn Pot:</u> A single control that replaces both coarse and fine current controls and improves output set-ability.
13	<u>Three Digit Graduated Decadial Voltage Control:</u> Control that replaces 10-turn voltage control permitting accurate resettability.
14	<u>Three Digit Graduated Decadial Current Control:</u> Control that replaces coarse and fine current controls permitting accurate resettability.
28	<u>230Vac Single Phase Input:</u> Supply as normally shipped is wired for 115Vac input. Option 28 consists of reconnecting the input transformer for 230Vac operation.

1-10 ACCESSORIES

1-11 The accessories listed in the following chart may be ordered with the power supply or separately from your local Hewlett-Packard field sales office (refer to list at rear of manual for addresses).

<u>Part No.</u>	<u>Description</u>
C05	8" Black Handle that can be attached to side of supply.

<u>Part No.</u>	<u>Description</u>
14513A	Rack Kit for mounting one 3½" high supply. (Refer to Section II for details.)
14523A	Rack Kit for mounting two 3½" high supplies. (Refer to Section II for details.)

1-12 INSTRUMENT IDENTIFICATION

1-13 Hewlett-Packard power supplies are identified by a three-part serial number tag. The first part is the power supply model number. The second part is the serial number prefix, which consists of a number-letter combination that denotes the date of a significant design change. The number designates the year, and the letter A through L designates the month, January through December, respectively,

with "I" omitted. The third part is the power supply serial number.

1-14 If the serial number prefix on your power supply does not agree with the prefix on the title page of this manual, change sheets are included to update the manual. Where applicable, backdating information is given in an appendix at the rear of the manual.

1-15 ORDERING ADDITIONAL MANUALS

1-16 One manual is shipped with each power supply. Additional manuals may be purchased from your local Hewlett-Packard field office (see list at rear of this manual for addresses). Specify the model number, serial number prefix, and part number provided on the title page.

Table 1-1. Specifications

INPUT:

115Vac \pm 10% 48-63Hz.

OUTPUT:

0-320 Volts @ 0.1 Amp.

LOAD REGULATION:

Constant Voltage - Less than 0.02% plus 2mV for a full load to no load change in output current.

Constant Current - Less than 200 μ A for a zero to maximum change in output voltage.

LINE REGULATION:

Constant Voltage - Less than 0.02% plus 2mV for any line voltage change within the input rating.

Constant Current - Less than 200 μ A for any line voltage change within the input rating.

RIPPLE AND NOISE:

Constant Voltage - Less than 1mV rms/40mV p-p.

Constant Current - Less than 200 μ Arms.

OPERATING TEMPERATURE RANGES:

Operating: 0 to 50°C. Storage: -40 to +75°C.

TEMPERATURE COEFFICIENT:

Constant Voltage - Less than 0.02% plus 1mV per degree Centigrade.

Constant Current - Less than 0.02% plus 150 μ A per degree Centigrade.

STABILITY:

Constant Voltage - Less than 0.10% plus 5mV total drift for 8 hours after an initial warmup time of 30 minutes at constant ambient, constant line voltage, and constant load.

Constant Current - Less than 0.10% plus 750 μ A total drift for 8 hours after an initial warmup time of 30 minutes at constant ambient, constant line voltage, and constant load.

INTERNAL IMPEDANCE AS A CONSTANT VOLTAGE SOURCE:

Less than 0.02 ohm from dc to 1kHz.

Less than 0.5 ohm from 1kHz to 100kHz.

Less than 3.0 ohms from 100kHz to 1MHz.

TRANSIENT RECOVERY TIME:

Less than 50 μ sec for output recovery to within 10mV following a full load current change in the output.

OVERLOAD PROTECTION:

A continuously acting constant current circuit protects the power supply for all overloads in-

cluding a direct short placed across the terminals in constant voltage operation. The constant voltage circuit limits the output voltage in the constant current mode of operation.

METER:

The front panel meter can be used as either a 0-400 or 0-40 Volt voltmeter or as a 0-0.12 or 0.012 Amp ammeter.

OUTPUT CONTROLS:

Ten-turn voltage control and course and fine current controls.

OUTPUT TERMINALS:

Three "five-way" output posts are provided on the front panel and an output terminal strip is located on the rear of the chassis. All power supply output terminals are isolated from the chassis and either the positive or negative terminal may be connected to the chassis through a separate ground terminal located on the output terminal strip.

ERROR SENSING:

Error sensing is normally accomplished at the front terminals if the load is attached to the front or at the rear terminals if the load is attached to the rear terminals. Also, provision is included on the rear terminal strip for remote sensing.

REMOTE RESISTANCE PROGRAMMING:

Constant Voltage - 300 Ω /V. Accuracy: 1%.

Constant Current - 150K Ω /A. Accuracy: 10%.

REMOTE VOLTAGE PROGRAMMING:

Constant Voltage - 1V/V. Accuracy: 1%.

Constant Current - 1.5V/.1A. Accuracy: 10%.

COOLING:

Convection cooling is employed. The supply has no moving parts.

SIZE:

3 $\frac{1}{2}$ " H x 12-5/8" D x 8 $\frac{1}{2}$ " W. Two of the units can be mounted side by side in a standard 19" relay rack.

WEIGHT: 13 lbs. net. 18 lbs. shipping.

FINISH:

Light gray front panel with dark gray case.

POWER CORD:

A three-wire, five-foot power cord is provided with each unit.

SECTION II INSTALLATION

2-1 INITIAL INSPECTION

2-2 Before shipment, this instrument was inspected and found to be free of mechanical and electrical defects. As soon as the instrument is unpacked, inspect for any damage that may have occurred in transit. Save all packing materials until the inspection is completed. If damage is found, file a claim with the carrier as soon as possible. Hewlett-Packard Sales and Service Office should be notified.

2-3 MECHANICAL CHECK

2-4 This check should confirm that there are no broken knobs or connectors, that the cabinet and panel surfaces are free of dents and scratches, and that the meter is not scratched or cracked.

2-5 ELECTRICAL CHECK

2-6 The instrument should be checked against its electrical specifications. Section V includes an "in-cabinet" performance check to verify proper instrument operation.

2-7 INSTALLATION

2-8 The instrument is shipped ready for bench operation. It is necessary only to connect the instrument to a source of power and it is ready for operation.

2-9 LOCATION

2-10 This instrument is air cooled. Sufficient space should be allotted so that a free flow of cooling air can reach the sides and rear of the instrument when it is in operation. It should be used in an area where the ambient temperature does not exceed 50°C.

2-11 OUTLINE DIAGRAM

2-12 Figure 2-1 is a diagram showing the outline dimensions of this unit.

2-13 RACK MOUNTING

2-14 This instrument may be rack mounted in a standard 19 inch rack panel either alongside a similar unit or by itself. Figures 2-2 and 2-3 show how both types of installations are accomplished.

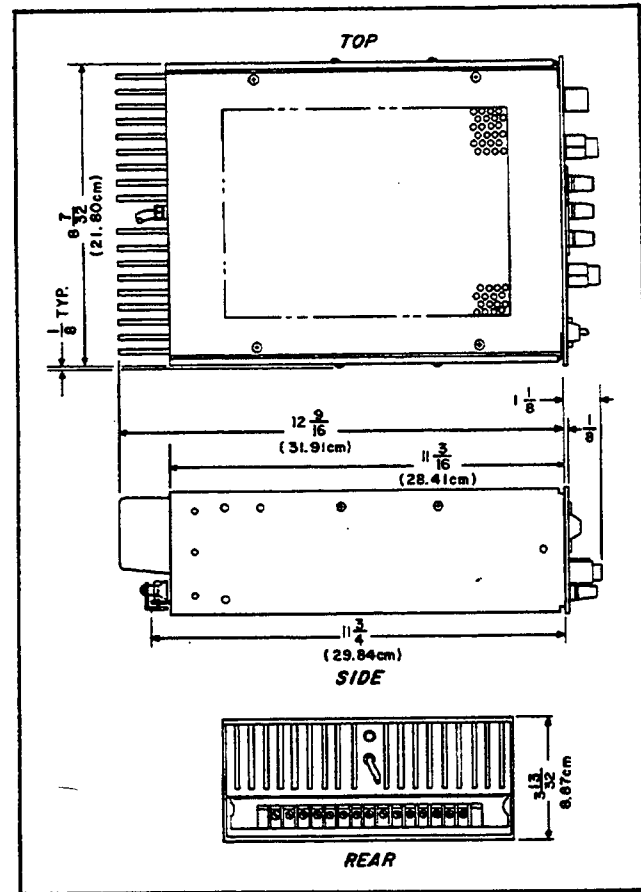

Figure 2-1. Outline Diagram

2-15 To mount two units side-by-side, proceed as follows:

- Remove the four screws from the front panels of both units.
- Slide rack mounting ears between the front panel and case of each unit.
- Slide combining strip between the front panels and cases of the two units.
- After fastening rear portions of units together using the bolt, nut, and spacer, replace panel screws.

2-16 To mount a single unit in the rack panel, proceed as follows:

- Bolt rack mounting ears, combining straps, and angle brackets to each side of center spacing panels. Angle brackets are placed behind combining straps as shown in Figure 2-3.
- Remove four screws from front panel of unit.

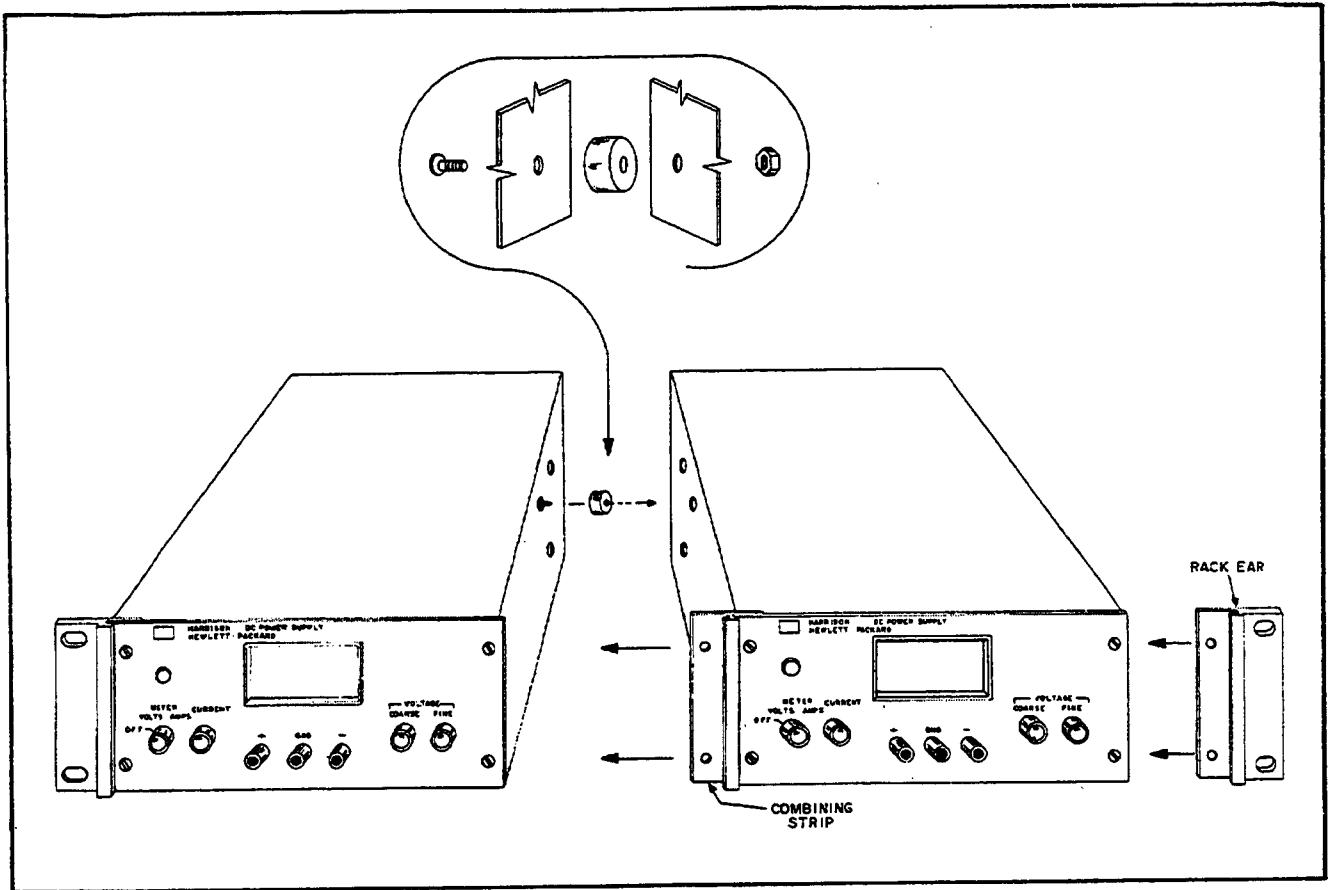

Figure 2-2. Rack Mounting, Two Units

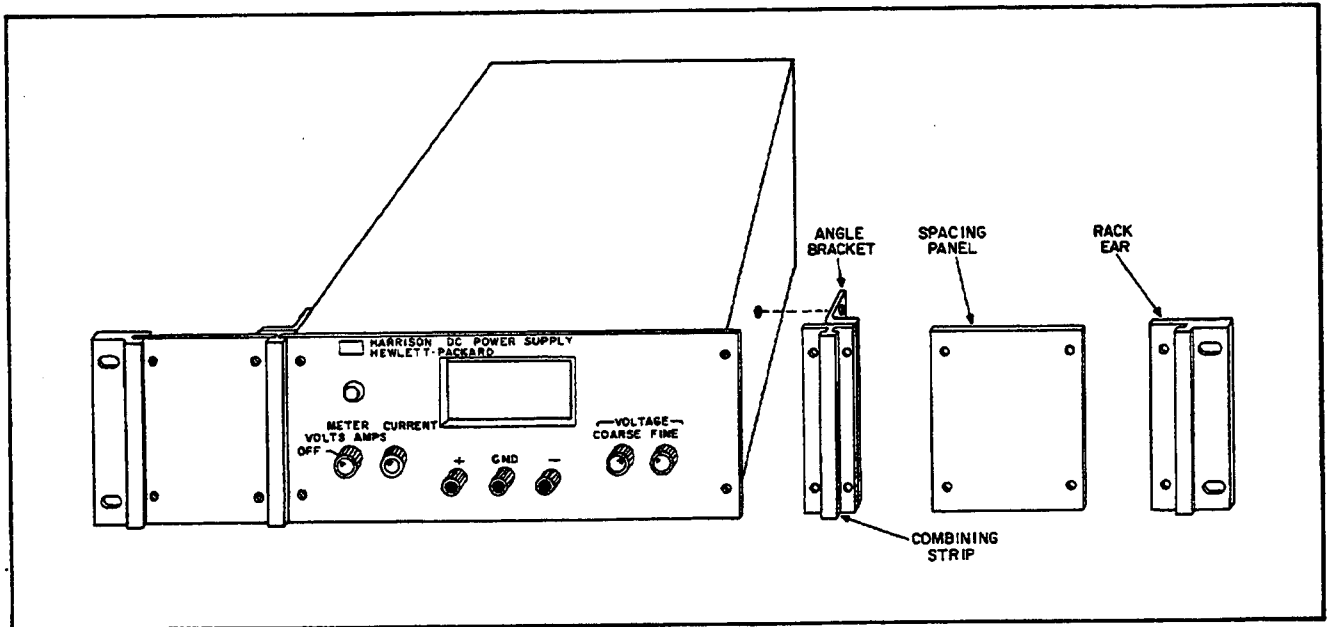

Figure 2-3. Rack Mounting, One Unit

c. Slide combining strips between front panel and case of unit.

d. Bolt angle brackets to front sides of case and replace front panel screws.

2-17 INPUT POWER REQUIREMENTS

2-18 This power supply may be operated from either a nominal 115 Volt or 230 Volt, 48-63Hz power source. The unit, as shipped from the factory, is wired for 115 Volt operation. The input power required when operated from a 115 Volt, 60 Hertz power source at full load is 60 Watts and 1.0 Ampere.

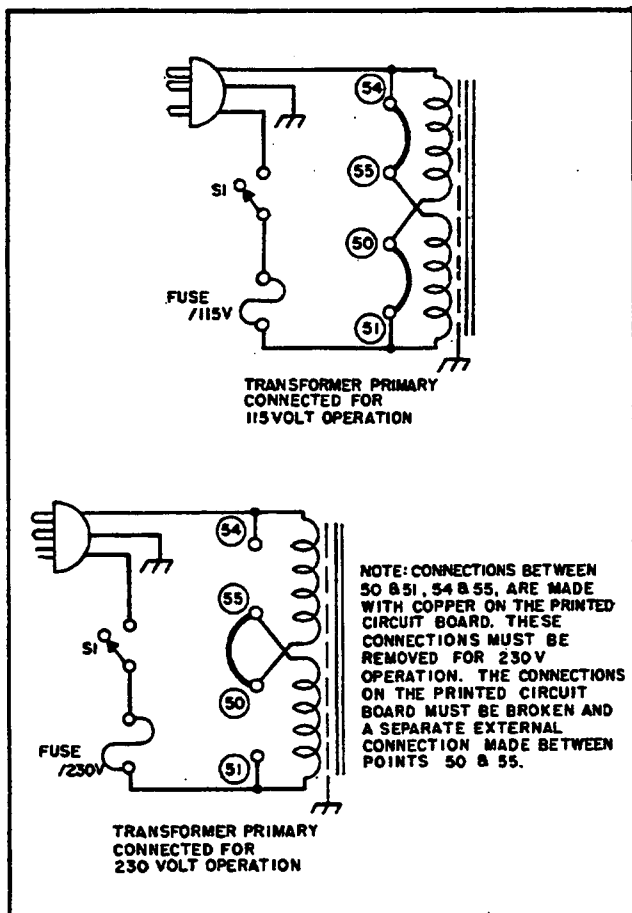

Figure 2-4. Primary Connections

2-19 CONNECTIONS FOR 230 VOLT OPERATION (Figure 2-4)

2-20 Normally, the two primary windings of the input transformer are connected in parallel for operation from 115V source. To convert the power supply to operation from a 230V source, the power transformer windings are connected in series as follows:

- Unplug the line cord and remove top and bottom covers from unit.
- Break the copper between 54 and 55 and also between 50 and 51 on the printed circuit board. These are shown in Figure 2-4 and are labeled on copper side of printed circuit board and on schematic.
- Add strap between 50 and 55.
- Replace existing fuse with 1 Ampere, 230-Volt fuse. Return unit to case and operate normally.

2-21 POWER CABLE

2-22 To protect operating personnel, the National Electrical Manufacturers' Association (NEMA) recommends that the instrument panel and cabinet be grounded. This instrument is equipped with a three conductor power cable. The third conductor is the ground conductor and when the cable is plugged into an appropriate receptacle, the instrument is grounded. The offset pin on the power cable three-prong connector is the ground connection.

2-23 To preserve the protection feature when operating the instrument from a two-contact outlet, use a three-prong to two-prong adapter and connect the green lead on the adapter to ground.

2-24 REPACKAGING FOR SHIPMENT

2-25 To insure safe shipment of the instrument, it is recommended that the package designed for the instrument be used. The original packaging material is reusable. If it is not available, contact your local Hewlett-Packard field office to obtain the materials. This office will also furnish the address of the nearest service office to which the instrument can be shipped. Be sure to attach a tag to the instrument which specifies the owner, model number, full serial number, and service required, or a brief description of the trouble.

SECTION III OPERATING INSTRUCTIONS

3-1 TURN-ON CHECK-OUT PROCEDURE

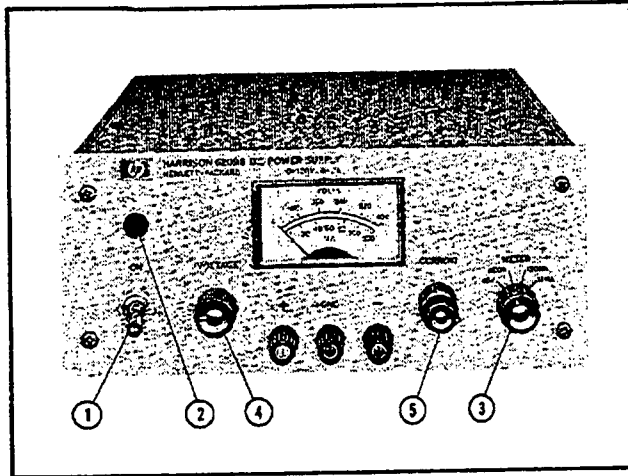

Figure 3-1. Front Panel Controls and Indicators

3-2 The following procedure describes the use of the front panel controls and indicators and ensures that the supply is operational (see Figure 3-1):

- a. Set AC Power Switch (1) to ON.
- b. Observe that Pilot Light (2) goes on.
- c. Set Meter Switch (3) to desired voltage range.
- d. Adjust coarse and fine Voltage Controls (4) until desired output voltage is indicated on Meter.
- e. Short circuit output terminals, set meter switch to desired current range and adjust Current Controls (5) for desired output current.
- f. Remove short and connect load to output terminals (Front or Rear).

3-3 OPERATING MODES

3-4 The power supply is designed so that its mode of operation can be selected by making strapping connections between particular terminals on the terminal strip at the rear of the power supply. The terminal designations are stenciled in white on the power supply above their respective terminals. Although the strapping patterns illustrated in this section show the positive terminal grounded, the operator can ground either terminal or operate the power supply up to 300Vdc off ground (floating). The following paragraphs describe the procedures for utilizing the various operational capabilities of the

power supply. A more theoretical description concerning the operational features of this supply is contained in Application Note 90 and in various Tech. Letters. Copies of these can be obtained from your local Hewlett-Packard field office.

3-5 NORMAL OPERATING MODE

3-6 The power supply is normally shipped with its rear terminal strapping connections arranged for Constant Voltage/Constant Current, local sensing, local programming, single unit mode of operation. This strapping pattern is illustrated in Figure 3-2. The operator selects either a constant voltage or a constant current output using the front panel controls (local programming, no strapping changes are necessary).

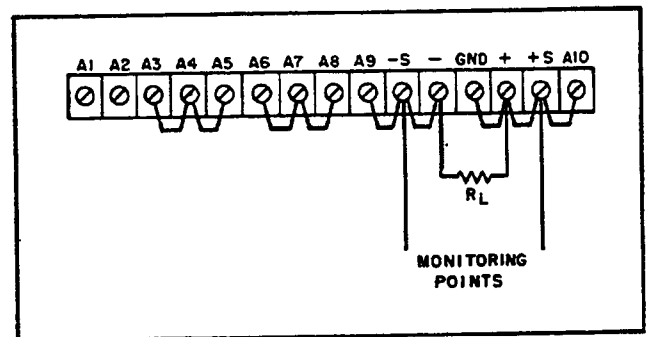

Figure 3-2. Normal Strapping Pattern

3-7 CONSTANT VOLTAGE

3-8 To select a constant voltage output, proceed as follows:

- a. Turn-on power supply and adjust VOLTAGE controls for desired output voltage (output terminals open).
- b. Short output terminals and adjust CURRENT controls for maximum output current allowable (current limit), as determined by load conditions. If a load change causes the current limit to be exceeded, the power supply will automatically crossover to constant current output at the preset current limit and the output voltage will drop proportionately. In setting the current limit, allowance must be made for high peak current which can cause unwanted cross-over. (Refer to Paragraph 3-48.)

3-9 CONSTANT CURRENT

3-10 To select a constant current output, proceed as follows:

- a. Short output terminals and adjust CURRENT controls for desired output current.
- b. Open output terminals and adjust VOLTAGE controls for maximum output voltage allowable (voltage limit), as determined by load conditions. If a load change causes the voltage limit to be exceeded, the power supply will automatically crossover to constant voltage output at the preset voltage limit and the output current will drop proportionately. In setting the voltage limit, allowance must be made for high peak voltages which can cause unwanted crossover. (Refer to Paragraph 3-48.)

3-11 CONNECTING LOAD

3-12 Each load should be connected to the power supply output terminals using separate pairs of connecting wires. This will minimize mutual coupling effects between loads and will retain full advantage of the low output impedance of the power supply. Each pair of connecting wires should be as short as possible and twisted or shielded to reduce noise pickup. (If shield is used, connect one end to power supply ground terminal and leave the other end unconnected.)

3-13 If load considerations require that the output power distribution terminals be remotely located from the power supply, then the power supply output terminals should be connected to the remote distribution terminals via a pair of twisted or shielded wires and each load separately connected to the remote distribution terminals. For this case, remote sensing should be used (Paragraph 3-31).

3-14 OPERATION BEYOND NORMAL RATED OUTPUT

3-15 The shaded area on the front panel meter face indicates the amount of output voltage or current that is available in excess of the normal rated output. Although the supply can be operated in this shaded region without being damaged, it cannot be guaranteed to meet all of its performance specifications. Generally when operating the supply in this manner, the output is unstable when a load is connected. However, if the line voltage is maintained above its nominal value, the supply will probably operate within the specifications above the rated output.

3-16 OPTIONAL OPERATING MODES

3-17 REMOTE PROGRAMMING, CONSTANT VOLTAGE

3-18 The constant voltage output of the power supply can be programmed (controlled) from a remote location if required. Either a resistance or voltage

source can be used for the programming device. The wires connecting the programming terminals of the supply to the remote programming device should be twisted or shielded to reduce noise pick-up. The VOLTAGE control on the front panel is disabled according to the following procedures.

3-19 Resistance Programming (Figure 3-3). In this mode, the output voltage will vary at a rate determined by the programming coefficient — 300 ohms per Volt (i.e. the output voltage will increase 1 Volt for each 300 ohms added in series with programming terminals). The programming accuracy is 1% of the programmed value. If greater programming accuracy is required, it may be achieved by changing resistor R13 (see Paragraph 5-79).

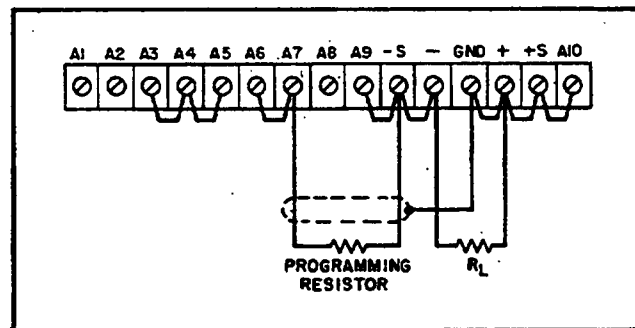

Figure 3-3. Remote Resistance Programming (Constant Voltage)

3-20 The output voltage of the power supply should be zero Volts \pm 20 millivolts when zero ohms is connected across the programming terminals. If a zero ohm voltage closer than this is required, it may be achieved by changing resistor R6 or R8 as described in Paragraph 5-77.

3-21 To maintain the stability and temperature coefficient of the power supply, use programming resistors that have stable, low noise, and low temperature (less than 30ppm per degree centigrade) characteristics. A switch can be used in conjunction with various resistance values in order to obtain discrete output voltages. The switch should have make-before-break contacts to avoid momentarily opening the programming terminals during the switching interval.

3-22 Voltage Programming (Figure 3-4). Employ the strapping pattern shown on Figure 3-4 for voltage programming. In this mode, the output voltage will vary in a 1 to 1 ratio with the programming voltage (reference voltage) and the load on the programming voltage source will not exceed 25 microamperes. The programming accuracy is 1% of the programmed voltage.

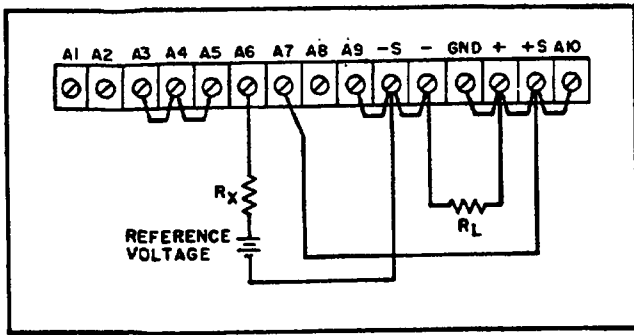

Figure 3-4. Remote Voltage Programming (Constant Voltage)

3-23 The impedance (R_x) looking into the external programming voltage source should be approximately 1000 ohms if the temperature and stability specifications of the power supply are to be maintained.

3-24 Methods of voltage programming with gain are discussed in Application Note 90, Power Supply Handbook; available at no charge from your local Hewlett-Packard Sales Office.

3-25 REMOTE PROGRAMMING, CONSTANT CURRENT

3-26 Either a resistance or a voltage source can be used to control the constant current output of the supply. The CURRENT controls on the front panel are disabled according to the following procedures.

3-27 Resistance Programming (Figure 3-5). In this mode, the output current varies at a rate determined by the programming coefficient — 75K ohms per Amp for Model 6207B, and 150K ohms per Amp for Model 6209B. The programming accuracy is 10% of the programmed current. If greater programming accuracy is required, it may be achieved by changing resistor R19 (see Paragraph 5-82).

3-28 Use stable, low noise, low temperature coef-

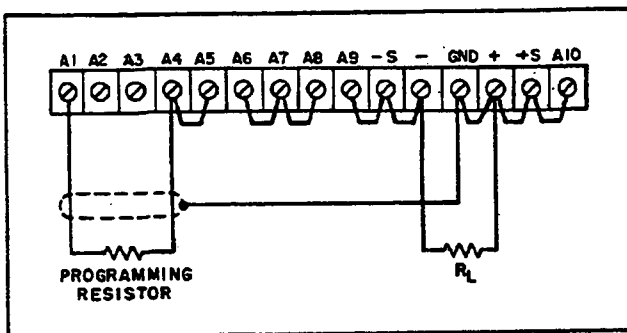

Figure 3-5. Remote Resistance Programming (Constant Current)

ficient (less than 30ppm/ $^{\circ}$ C) programming resistors to maintain the power supply temperature coefficient and stability specifications. A switch may be used to set discrete values of output current. A make-before-break type of switch should be used since the output current will exceed the maximum rating of the power supply if the switch contacts open during the switching interval.

CAUTION

If the programming terminals (A1 and A4) should open at any time during this mode, the output current will rise to a value that may damage the power supply and/or the load. To avoid this possibility, connect a 15K resistor across the programming terminals and in parallel with a remote programming resistor. Like the programming resistor, the 15K resistor should be of the low noise, low temperature coefficient type.

3-29 Voltage Programming (Figure 3-6). In this mode, the output current will vary linearly with changes in the programming voltage. The programming voltage should not exceed 1.8 Volts. Voltage in excess of 1.8 Volts will result in excessive power dissipation in the instrument and possible damage.

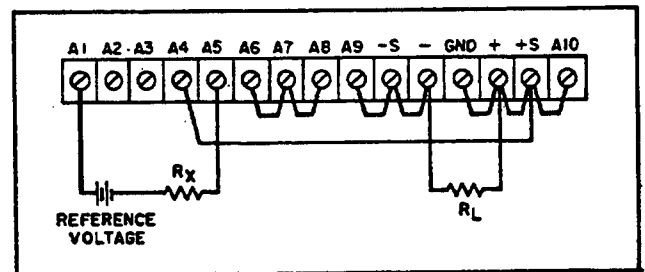

Figure 3-6. Remote Voltage Programming (Constant Current)

3-30 The output current for Model 6207B supplies will be the programming voltage divided by 7.5 ohms. For Model 6209B supplies, it will be the programming voltage divided by 15 ohms. The current required from the voltage source will be less than 25 microamperes. The impedance (R_x) as seen looking into the programming voltage source should be approximately 500 ohms if the temperature coefficient and stability specifications of the power supply are to be maintained. The programming accuracy is 10% of the programmed current.

3-31 REMOTE SENSING (See Figure 3-7)

3-32 Remote sensing is used to maintain good reg-

ulation at the load and reduce the degradation of regulation which would occur due to the voltage drop in the leads between the power supply and the load. Remote sensing is accomplished by utilizing the strapping pattern shown in Figure 3-7. The power supply should be turned off before changing strapping patterns. The leads from the +S terminals to the load will carry less than 10 milliamperes of current, and it is not required that these leads be as heavy as the load leads. However, they must be twisted or shielded to minimize noise pick-up.

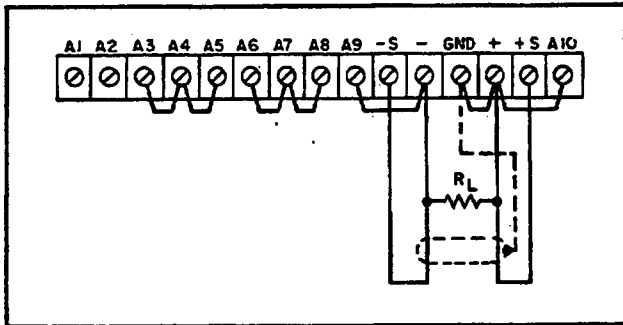

Figure 3-7. Remote Sensing

CAUTION

Observe polarity when connecting the sensing leads to the load.

3-33 For reasonable load lead lengths, remote sensing greatly improves the performance of the supply. However, if the load is located a considerable distance from the supply, added precautions must be observed to obtain satisfactory operation. Notice that the voltage drop in the load leads subtracts directly from the available output voltage and also reduces the amplitude of the feedback error signals that are developed within the unit. Because of these factors it is recommended that the drop in each load lead not exceed 1 Volt. If a larger drop must be tolerated, please consult a Hewlett-Packard Sales Engineer.

NOTE

Due to the voltage drop in the load leads, it may be necessary to readjust the current limit in the remote sensing mode.

3-34 Another factor that must be considered is the inductance of long load leads which could affect the stability of the feedback loop and cause oscil-

lation. In these cases, it is recommended that the output capacitor (C20) be physically removed from the power supply and placed across the load terminals.

3-35 Although the strapping patterns shown in Figures 3-3 through 3-6 employ local sensing, note that it is possible to operate a power supply simultaneously in the remote sensing and Constant Voltage/Constant Current remote programming modes.

3-36 SERIES OPERATION

3-37 Normal Series Connections (Figure 3-8). Two or more power supplies can be operated in series to obtain a higher voltage than that available from a single supply. When this connection is used, the output voltage is the sum of the voltages of the individual supplies. Each of the individual supplies must be adjusted in order to obtain the total output voltage. The power supply contains a protective diode connected internally across the output which protects the supply if one power supply is turned off while its series partner(s) is on.

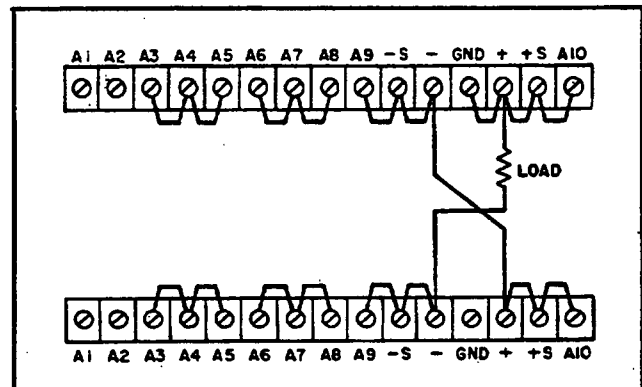

Figure 3-8. Normal Series

3-38 Auto-Series Connections (Figure 3-9). The Auto-Series configuration is used when it is desirable to have the output voltage of each of the series connected supplies vary in accordance with the setting of a control unit. The control unit is called the master; the controlled units are called slaves. At maximum output voltage, the voltage of the slaves is determined by the setting of the front panel VOLTAGE control on the master. The master supply must be the most positive supply of the series. The output CURRENT controls of all series units are operative and the current limit is equal to the lowest control setting. If any output CURRENT controls are set too low, automatic crossover to constant current operation will occur and the output voltage will drop. Remote sensing and programming can be used; however, the strapping arrangements shown in the applicable figures show local sensing and programming.

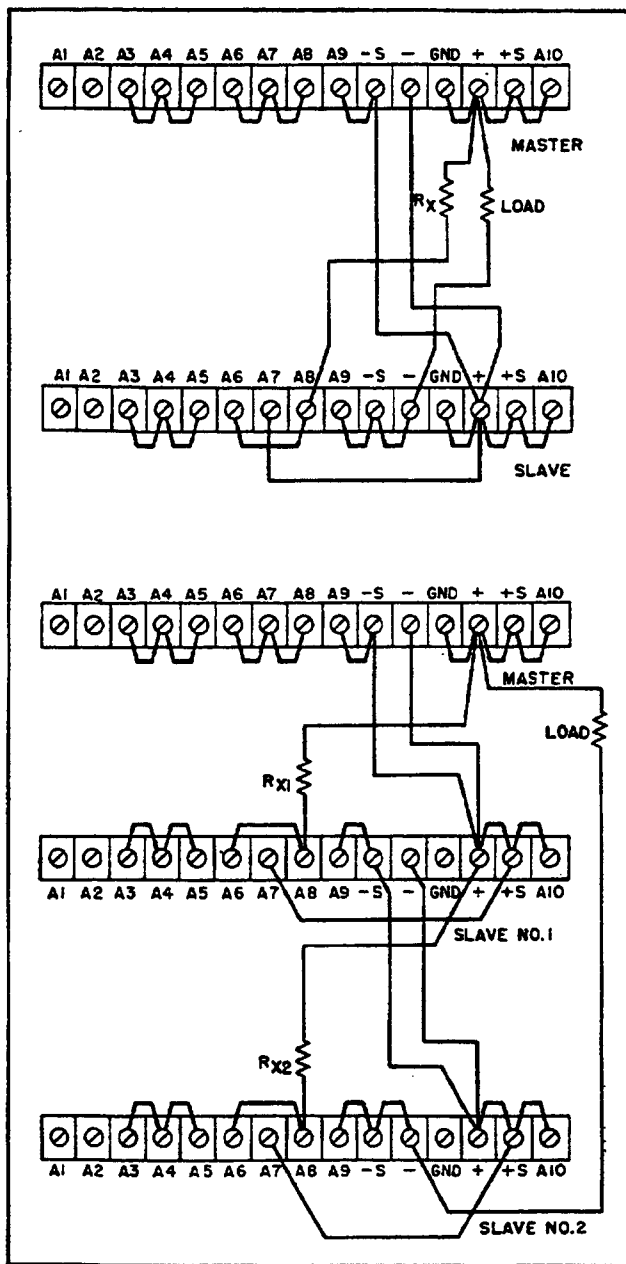

Figure 3-9. Auto-Series, Two and Three Units

3-39 In order to maintain the temperature coefficient and stability specifications of the power supply, the external resistors (R_x) shown in Figure 3-9 should be stable, low noise, low temperature coefficient (less than 30ppm per degree centigrade) resistors. The value of each resistor is dependant on the maximum voltage rating of the "master" supply. The value of R_x is this voltage divided by the voltage programming current of the slave supply ($1/K_p$ where K_p is the voltage programming coefficient). The voltage contribution of the slave is determined by its voltage control setting.

3-40 When the center tap of an Auto-Series combi-

nation is grounded, coordinated positive and negative voltages result. This technique is commonly referred to as "rubber-banding" and an external reference source may be employed if desired. Any change in the internal or external reference source (e.g. drift, ripple) will cause an equal percentage change in the outputs of both the master and slave supplies. This feature can be of considerable use in analogue computer and other applications, where the load requires a positive and a negative power supply and is less susceptible to an output voltage change occurring simultaneously in both supplies than to a change in either supply alone.

3-41 PARALLEL OPERATION

3-42 Normal Parallel Connections (Figure 3-10).

Two or more power supplies can be connected in parallel to obtain a total output current greater than that available from one power supply. The total output current is the sum of the output currents of the individual power supplies. The output CURRENT controls of each power supply can be separately set. The output voltage controls of one power supply should be set to the desired output voltage; the other power supply should be set for a slightly larger output voltage. The supply set to the lower output voltage will act as a constant voltage source; the supply set to the higher output will act as a constant current source, dropping its output voltage until it equals that of the other supply. The constant voltage source will deliver only that fraction of its total rated output current which is necessary to fulfill the total current demand.

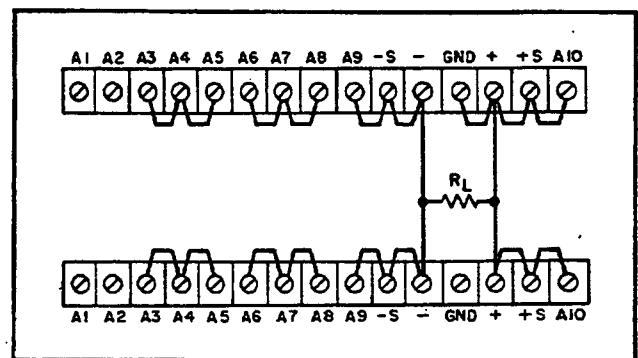

Figure 3-10. Normal Parallel

3-43 Auto-Parallel. The strapping patterns for Auto-Parallel operation of two and three power supplies are shown in Figure 3-11. Auto-Parallel operation permits equal current sharing under all load conditions, and allows complete control of output current from one master power supply. The output current of each slave is approximately equal to the master's. Because the output current controls of each slave are operative, they should be set to

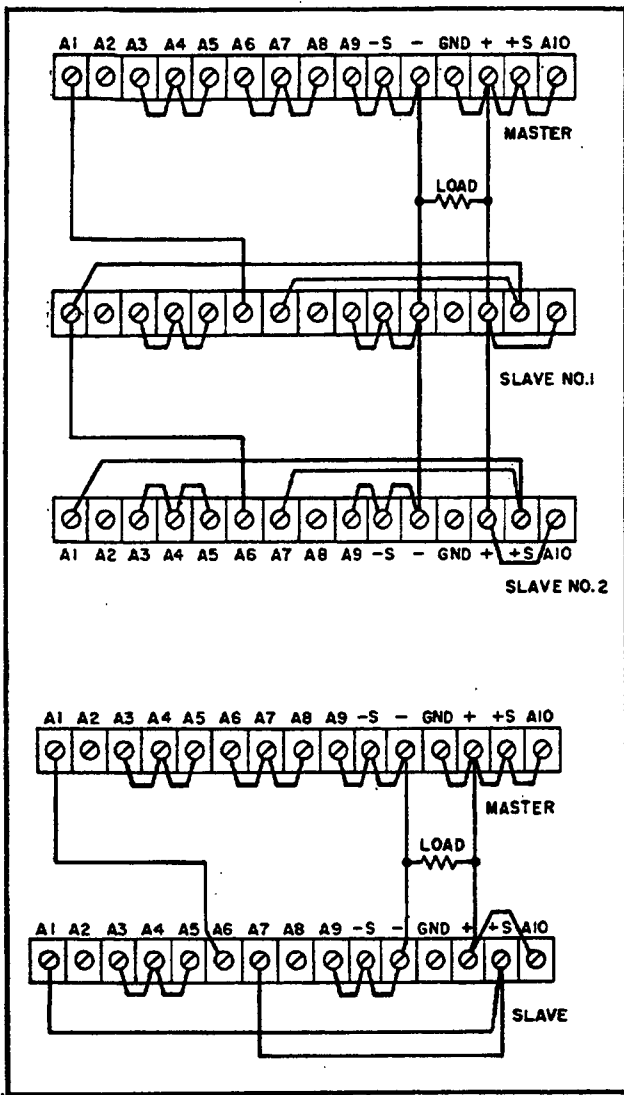

Figure 3-11. Auto-Parallel, Two and Three Units

maximum to avoid having the slave revert to constant current operation; this would occur if the master output current setting exceeded the slave's.

3-44 AUTO-TRACKING OPERATION (See Figure 3-12)

3-45 The Auto-Tracking configuration is used when it is necessary that several different voltages referred to a common bus, vary in proportion to the setting of a particular instrument (the control or master). A fraction of the master's output voltage is fed to the comparison amplifier of the slave supply, thus controlling the slave's output. The master must have the largest output voltage of any power supply in the group (must be the most positive supply in the example shown on Figure 3-12).

3-46 The output voltage of the slave is a percentage of the master's output voltage, and is determined by the voltage divider consisting of R_x (or R_x

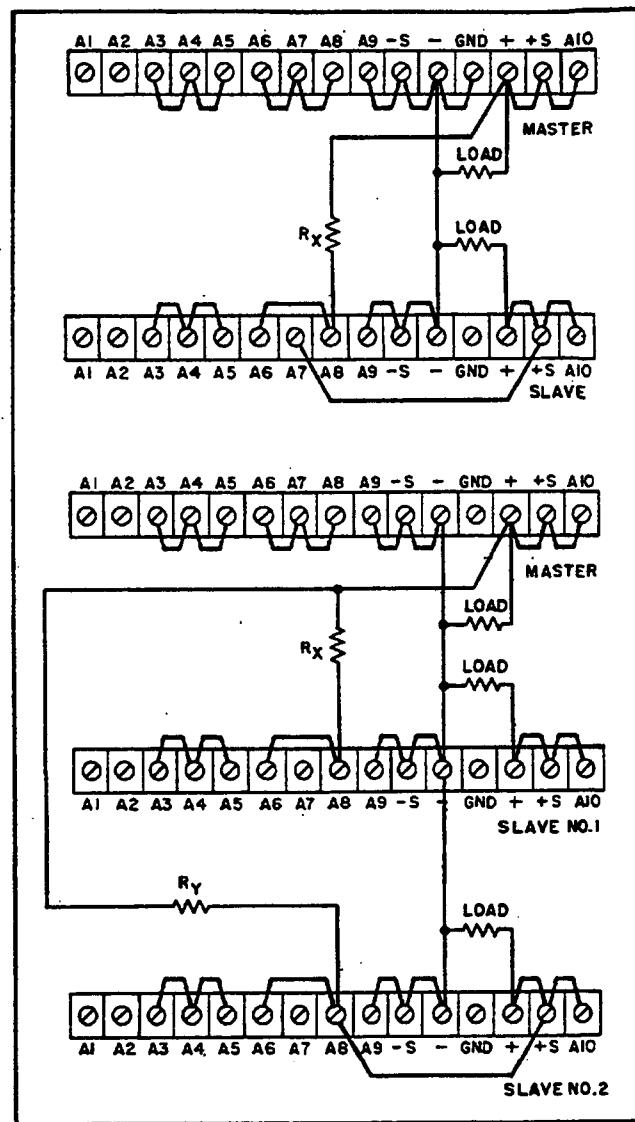

Figure 3-12. Auto-Tracking, Two and Three Units

and R_y) and the voltage control of the slave supply, R_p where: $E_S = E_M \cdot R_p / (R_x + R_p)$. Turn-on and turn-off of the power supplies is controlled by the master. Remote sensing and programming can be used; although the strapping patterns for these modes show only local sensing and programming. In order to maintain the temperature coefficient and stability specifications of the power supply, the external resistors should be stable, low noise, low temperature (less than 30ppm per $^{\circ}\text{C}$) resistors.

3-47 SPECIAL OPERATING CONSIDERATIONS

3-48 PULSE LOADING

3-49 The power supply will automatically cross over from constant voltage to constant current operation, or the reverse, in response to an increase (over the preset limit) in the output current or volt-

age, respectively. Although the preset limit may be set higher than the average output current or voltage, high peak currents or voltages (as occur in pulse loading) may exceed the preset limit and cause crossover to occur. If this crossover limiting is not desired, set the preset limit for the peak requirement and not the average.

3-50 OUTPUT CAPACITANCE

3-51 An internal capacitor (C20), connected across the output terminals of the power supply, helps to supply high-current pulses of short duration during constant voltage operation. Any capacitance added externally will improve the pulse current capability, but will decrease the safety provided by the constant current circuit. A high-current pulse may damage load components before the average output current is large enough to cause the constant current circuit to operate.

3-52 The effects of the output capacitor during constant current operation are as follows:

- a. The output impedance of the power supply decreases with increasing frequency.
- b. The recovery time of the output voltage is longer for load resistance changes.
- c. A large surge current causing a high power

er dissipation in the load occurs when the load resistance is reduced rapidly.

3-53 REVERSE VOLTAGE LOADING

3-54 A diode (CR34) is connected across the output terminals. Under normal operating conditions, the diode is reverse biased (anode connected to negative terminal). If a reverse voltage is applied to the output terminals (positive voltage applied to negative terminal), the diode will conduct, shunting current across the output terminals and limiting the voltage to the forward voltage drop of the diode. This diode protects the series transistors and the output electrolytic capacitors.

3-55 REVERSE CURRENT LOADING

3-56 Active loads connected to the power supply may actually deliver a reverse current to the power supply during a portion of its operating cycle. An external source cannot be allowed to pump current into the supply without loss of regulation and possible damage to the output capacitor. To avoid these effects, it is necessary to preload the supply with a dummy load resistor so that the power supply delivers current through the entire operating cycle of the load device.

SECTION IV PRINCIPLES OF OPERATION

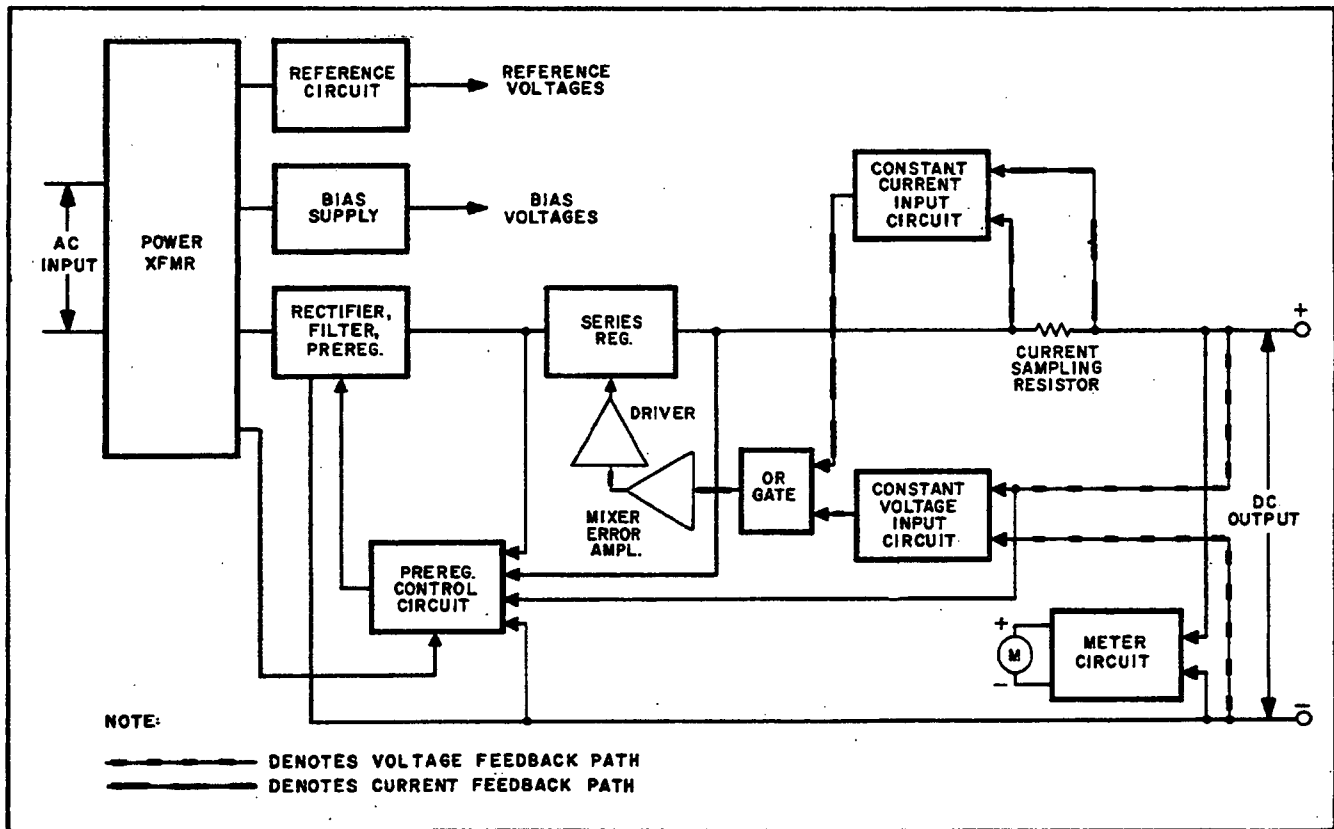

Figure 4-1. Overall Block Diagram

4-1 OVERALL BLOCK DIAGRAM DISCUSSION

4-2 The major circuits of the power supply are shown on the overall block diagram of Figure 4-1. The ac input voltage is first rectified and applied to the preregulator SCR which operates in conjunction with the SCR control circuit to form a feedback loop. This preregulator feedback loop minimizes the power dissipated by the series regulator by keeping the voltage drop across the regulator at a low and constant level.

4-3 To accomplish this, the SCR control circuit issues a phase adjusted firing pulse to the SCR once during each half cycle of the input ac. The control circuit continuously samples the output voltage, the input line voltage (from T3), and the voltage across the series regulator and, on the basis of these inputs, determines at what time each firing pulse is generated.

4-4 The phase adjusted output of the SCR is applied to the series regulator which varies its conduction to provide a regulated voltage or current at the output terminals.

4-5 The series regulator is part of another feedback loop which consists of the error and driver amplifiers and the Constant Voltage/Constant Current comparators. The series regulator feedback loop provides fine and "fast" regulation of the output while the preregulator feedback loop handles large, relatively slow, regulation demands.

4-6 The feedback signals that control the conduction of the series regulator are originated within the constant voltage or constant current comparator. During constant voltage operation the constant voltage comparator continuously compares the output voltage of the supply with the drop across the VOLTAGE controls. If these voltages are not equal, the

comparator produces an amplified error signal which is further amplified by the error amplifier and then fed back to the series regulator in the correct phase and amplitude to counteract the difference. In this manner, the constant voltage comparator helps to maintain a constant output voltage and also generates the "error" signals necessary to set the output voltage at the level that is established by the VOLTAGE controls.

4-7 During constant current operation, the constant current comparator detects any difference between the voltage drop across the current sampling resistor and the voltage across the CURRENT controls. The voltage drop across the current sampling resistor is directly proportional to the output current that flows through it. If the two inputs to the comparator are momentarily unequal, an error signal is generated which alters the conduction of the series regulator by the amount necessary to reduce the error voltage at the comparator input to zero. Hence, the IR drop across the current sampling resistor, and therefore, the output current, is maintained at a constant value.

4-8 Since the constant voltage comparator tends to achieve zero output impedance and alters the output current whenever the load resistance changes, while the constant current comparator causes the output impedance to be infinite and changes the output voltage in response to any load resistance change, it is obvious that the two comparison amplifiers cannot operate simultaneously. For any given value of load resistance, the power supply must act either as a constant voltage source or as a constant current source — it cannot be both.

4-9 Figure 4-2 shows the output characteristic of a Constant Voltage/Constant Current power supply. With no load attached ($R_L = \infty$), $I_{OUT} = 0$, and $E_{OUT} = E_S$, the front panel voltage control setting. When a load resistance is applied to the output terminals of the power supply, the output current increases, while the output voltage remains constant; point D thus represents a typical constant voltage operating point. Further decreases in load resistance are accompanied by further increases in I_{OUT} with no change in the output voltage until the output current reaches I_S , a value equal to the front panel current control setting. At this point the supply automatically changes its mode of operation and becomes a constant current source; still further decreases in the value of load resistance are accompanied by a drop in the supply output voltage with no accompanying change in the output current value. With a short circuit across the output load terminals, $I_{OUT} = I_S$ and $E_{OUT} = 0$.

4-10 The "crossover" value of load resistance can be defined as $R_C = E_S / I_S$. Adjustment of the front

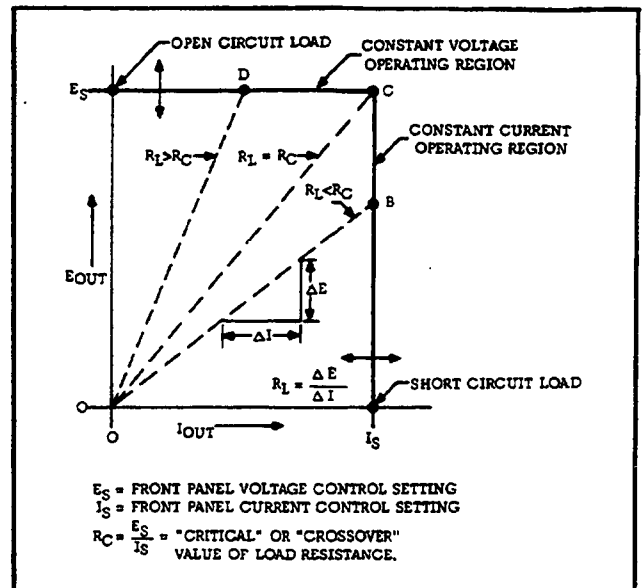

Figure 4-2. Operating Locus of a CV/CC Power Supply

panel voltage and current controls permits this "crossover" resistance R_C to be set to any desired value from 0 to ∞ . If R_L is greater than R_C , the supply is in constant voltage operation, while if R_L is less than R_C , the supply is in constant current operation.

4-11 The turn-on control circuit is a long time constant network which achieves a gradual turn-on characteristic. The slow turn-on feature protects the preregulator SCR's and the series regulator from damage which might occur when power is first applied to the unit. At turn-on, the control circuit and the series regulator (via the error and driver amplifiers). A short time after the unit is in operation, the inhibit voltages are removed and the circuit no longer exercises any control over the operation of the supply.

4-12 The reference supply provides stable reference voltages which are used by the constant voltage and current comparators in the main power supply. Less critical operating voltages are obtained from the bias supply.

4-13 DETAILED CIRCUIT ANALYSIS (Refer to Schematic at Rear of Manual.)

4-14 PREREGULATOR AND CONTROL CIRCUIT

4-15 The preregulator minimizes changes in the power dissipated by the series regulator due to output voltage, load current, or input line voltage changes. Preregulation is accomplished by means of a phase control circuit utilizing an SCR (CR35)

as the switching element. The SCR is fired once during each half-cycle (8.33 milliseconds) of the rectified ac (see Figure 4-3). Notice that when the SCR is fired at an early point during the half-cycle the dc level applied to the series regulator is fairly high. When the SCR is fired later during the cycle, the dc level is relatively low.

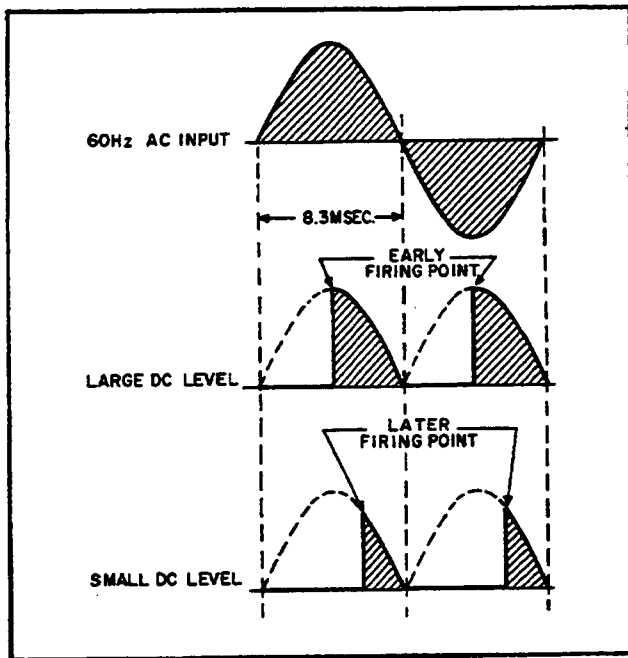

Figure 4-3. SCR Phase Control Over DC Input Level

4-16 The SCR control circuit samples the input line voltage, the output voltage, and the voltage across the series transistor. It generates a firing pulse, at the time required, to fire the SCR so that the voltage across input capacitor C14 will be maintained at the desired level.

4-17 The inputs to the control circuit are algebraically summed across capacitor C22. All inputs contribute to the time required to charge C22. The input line voltage is rectified by CR9 and CR12, attenuated by voltage divider R100 and R101, and applied to the summing point at TP66 via capacitor C22. Capacitor C23 is used for smoothing purposes. Resistor R82, connected between the minus output terminals and the summing point, furnishes a voltage drop which is proportional to the output voltage. Resistors R91 and R92 sample the voltage across the series transistor, Q6. Resistor R93 and capacitor C24 stabilize the control circuit feedback loop. Resistors R97 and R99 are the source of an offset current which varies with the output current. This offset current sustains a negative charging current to the summing capacitor ensuring that the SCR will fire at low output voltages.

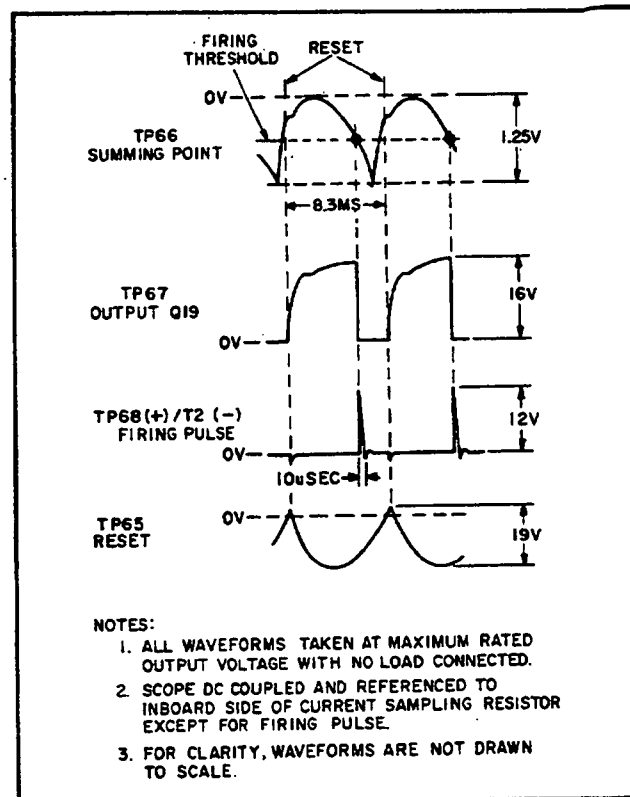

Figure 4-4. Preregulator Control Circuit Waveforms

4-18 The summation of the input signals results in the generation of a voltage waveform similar to that shown on Figure 4-4. The linear ramp portion of the waveform starts at zero Volts (with no load connected and at full rated output voltage) and, when a certain negative threshold voltage is reached, forward biases diodes CR16 and CR17. The negative voltage then is coupled to the base of transistor Q18. Transistors Q18 and Q19 form a squaring circuit similar to a Schmitt trigger configuration. Q18 is conducting, prior to firing time, due to the positive bias connected to its base through R94. Transistor Q19 is cutoff at this time because its base is connected directly to the collector of conducting transistor Q18. When the negative threshold voltage is reached, transistor Q18 is driven towards cutoff and transistor Q19 begins to conduct. The collector voltage of Q19 decays very rapidly as shown on Figure 4-4. The conduction of Q19 allows capacitor C17 to discharge rapidly through pulse transformer T2 resulting in the SCR firing pulse shown on the diagram. The firing pulse is relatively narrow (about 10µsec) because when Q19 reaches saturation the magnetic field surrounding T2 collapses driving the voltage in a negative direction.

4-19 Reset of the control circuit occurs once every 8.33 milliseconds when the rectified ac voltage at TP65 recedes to a level at which diode CR15 be-

comes forward biased. Summing capacitor C22 is then allowed to completely discharge through CR15. Diodes CR16 and CR17 become reverse biased at reset and transistor Q18 reverts to its "on" state. Consequently, Q19 is turned off and capacitor C17 charges up through R96 at a comparatively slow rate until the collector voltage of Q19 reaches approximately +16 Volts. The above action causes the small negative spike that appears across the winding of pulse transformer T2 at reset time.

4-20 TURN-ON CONTROL CIRCUIT

4-21 This circuit is a long time-constant network which protects the SCR and series regulator from possible damage during turn-on. When the power supply is first turned on, C26 provides a positive voltage to the anode of CR19 which is connected to the base of Q3. Q3 inverts this voltage and passes it on to the series regulator via Q4. The series regulator is thus turned off, until C26 becomes sufficiently charged to reverse bias CR19.

4-22 C26 initially passes a positive voltage to the cathode of CR16, in the SCR control circuit, via R98 and R99. This ensures that this diode is reverse biased and that no firing pulses are generated until C26 is sufficiently charged to provide the proper bias to CR16. CR18 provides a discharge path for C26 during turn-off.

4-23 Capacitor C26, diode CR18, and resistor R98 form a long time constant network which achieves a slow turn-on characteristic. When the unit is first turned on, C26 provides a positive voltage to the cathode of CR16 to ensure that it is initially reverse biased. After C26 becomes fully charged, the control circuit is permitted to fire the SCR. Diode CR18 provides a discharge path for C26 when the unit is turned-off.

4-24 SERIES REGULATOR

4-25 The series regulator, (transistor Q6) serves as the series element, or pass transistor, which provides precise and fast control of the output. The conduction of Q6 is varied in accordance with feedback control signals obtained from driver Q4. Zener diode VR3, connected across Q6 and R54, protects the series transistor if the output terminals of the supply are shorted. Resistor R81 limits the current through VR3.

4-26 CONSTANT VOLTAGE COMPARATOR CIRCUIT

4-27 The circuit consists of the programming resistor (R10) and a differential amplifier stage (Q1 and associated components). Transistor Q1 consists of two silicon transistors housed in a single package. The transistors have matched character-

istics minimizing differential voltages due to mismatched stages. Moreover, drift due to thermal differentials is minimized, since both transistors operate at essentially the same temperature.

4-28 The constant voltage comparator circuit continuously compares a fixed reference voltage with a portion of the output voltage and, if a difference exists, produces an error voltage whose amplitude and phase is proportional to the difference. The error output is fed back to the series regulator, through OR gate diode CR3 and the mixer and driver amplifiers. The error voltage changes the conduction of the series regulator which, in turn, alters the output voltage so that the difference between the two input voltages applied to the differential amplifier is reduced to zero. This action maintains the output voltage constant.

4-29 Stage Q1B of the differential amplifier is connected to a common (+S) potential through impedance equalizing resistor R5. Resistor R6 and R8 are used to zero bias the input stage, offsetting minor base to emitter voltage differences in Q1. The base of Q1A is connected to a summing point (A6) at the junction of the programming resistors and the current pullout resistor R12. Instantaneous changes in the output (due to load variations) or changes due to the manipulation of R10, result in an increase or decrease in the summing point potential. Q1A is then made to conduct more or less, in accordance with summing point voltage change. The resultant output "error" voltage is fed back to the series regulator via the remaining components of the feedback loop. Resistor R1, in series with the base of Q1A, limits the current through the programming resistor during rapid voltage turn-down. Diodes CR1 and CR2 form a limiting network which prevents excessive voltage excursions from over driving stage Q1A. Capacitors C1 and C2, shunting the programming resistor, increase the high frequency gain of the input amplifier.

4-30 During constant voltage operation, the programming current that flows through the programming resistors (VOLTAGE controls) is constant because the value of shunt resistor R12 is factory selected so that all of the +6.2 Volt reference is dropped across R12 and R13. Linear constant voltage programming is assured with a constant current flowing through R10.

4-31 Main output capacitor C20, connected across the output terminals of the supply, stabilizes the series regulator feedback loop when the normal strapping pattern shown on the schematic is employed. Note that this capacitor can be removed to avoid output current surges or to increase the programming speed of the supply. If C20 is removed, capacitor C19 serves to insure loop stability.

4-32 CONSTANT CURRENT COMPARATOR CIRCUIT

4-33 This circuit is similar in appearance and operation to the constant voltage comparator circuit. It consists of the coarse and fine current programming resistors (R16A and R16B), and a differential amplifier stage (Q2 and associated components). Like transistor Q1 in the voltage input circuit, Q2 consists of two transistors, having matched characteristics, that are housed in a single package.

4-34 The constant current comparator circuit continuously compares a fixed reference voltage with the voltage drop across the current sampling resistor. If a difference exists, the differential amplifier produces an "error" voltage which is proportional to this difference. The remaining components in the feedback loop (amplifiers and series regulator) function to maintain the drop across the current-sampling resistor, and consequently the output current, at a constant value.

4-35 Stage Q2B is connected to +S through impedance equalizing resistor R26. Resistors R25 and R28 are used to zero bias the input stage, offsetting minor base to emitter voltage differences in Q2. Instantaneous changes in output current on the positive line are felt at the current summing point (terminal A5) and, hence, the base of Q2A. Stage Q2A varies its conduction in accordance with the polarity of the change at the summing point. The change in Q2A's conduction also varies the conduction of Q2B due to the coupling effects of the common emitter resistor, R22. The error voltage is taken from the collector Q2B and ultimately varies the conduction of the series regulator.

4-36 Resistor R20, in conjunction with R21 and C3, helps stabilize the feedback loop. Diode CR5 limits voltage excursions on the base of Q2A. Resistor R19, shunting the pullout resistor, serves as a trimming adjustment for the programming current flowing through R16A and R16B.

4-37 VOLTAGE CLAMP CIRCUIT

4-38 The voltage clamp circuit keeps the constant voltage programming current relatively constant when the power supply is operating in the constant current mode. This is accomplished by clamping terminal A6, the voltage summing point, to a fixed bias voltage. During constant current operation the constant voltage programming resistor is a shunt load across the output terminals of the power supply. When the output voltage changes, the current through this resistor also tends to change. Since this programming current flows through the current sampling resistor, it is erroneously interpreted as a load change by the current comparator circuit. The clamp circuit eliminates this undesirable effect

by maintaining the constant voltage programming current constant.

4-39 The voltage divider, R51, R52, and VR5, back biases CR30 and Q10 during constant voltage operation. When the power supply goes into constant current operation, CR30 becomes forward biased by the collector voltage of Q1A. This results in conduction of Q10 and the clamping of the summing point at a potential only slightly more negative than the normal constant voltage potential. Clamping this voltage at approximately the same potential that exists in constant voltage operation, results in a constant voltage across, and consequently a constant current through, the current pullout resistor (R12).

4-40 MIXER AND DRIVER AMPLIFIERS

4-41 The mixer and driver amplifiers amplify the error signal from the constant voltage or constant current input circuit to a level sufficient to drive the series regulator transistor. Transistor Q3 receives the error voltage input from either the constant voltage or constant current circuit via the OR-gate diode (CR3 or CR4) that is conducting at the time. Diode CR3 is forward biased, and CR4 reversed biased, during constant voltage operation. The reverse is true during constant current operation.

4-42 The RC network, composed of C5 and R30, is an equalizing network which provides for high frequency roll off in the loop gain response in order to stabilize the feedback loop. Amplifier Q4 serves as the driver element for the series regulator.

4-43 REFERENCE CIRCUIT

4-44 The reference circuit is a feedback power supply similar to the main supply. It provides stable reference voltages which are used throughout the unit. The reference voltages are all derived from smoothed dc obtained from the full wave rectifier (CR22 and CR23) and filter capacitor C10. The +6.2 and -6.2 voltages, which are used in the constant voltage and current input circuits for comparison purposes, are developed across temperature compensated Zener diodes VR1 and VR2. Resistor R43 limits the current through the Zener diodes to establish an optimum bias level.

4-45 The regulating circuit consists of series regulating transistor Q9 and error amplifier Q8. Output voltage changes are detected by Q8 whose base is connected to the junction of a voltage divider (R41, R42) connected directly across the supply. Any error signals are amplified and inverted by Q8 and applied to the base of series transistor Q9. The series element then alters its conduction in the direction and by the amount necessary to maintain the voltage across the supply constant. Resistor R46, the emit-

ter resistor for Q8, is connected in a manner which minimizes changes in the reference voltage caused by variations in the input line. Output capacitor C9 stabilizes the regulator loop.

4-46 METER CIRCUIT

4-47 The meter circuit provides continuous indications of output voltage or current on a single multiple range meter. The meter can be used either as a voltmeter or an ammeter depending upon the position of METER switch S2 on the front panel of the supply. This switch also selects one of two meter ranges on each scale. The metering circuit consists basically of a selection circuit (switch S2 and associated voltage dividers), a stable differential amplifier stage (Q11 through Q14), and the meter movement.

4-48 The selection circuit determines which voltage divider is connected to the differential amplifier input. When S2 is in one of the voltage positions, the voltage across divider R59, R60, and R61 (connected across the output of the supply) is the input to the differential amplifier. When S2 is in one of the current positions, the voltage across divider R14, and R55 through R58 (connected across the sampling resistor) is the input to the differential amplifier. The amplified output of the differential amplifier is used to deflect the meter.

4-49 The differential amplifier is a stable device having a fixed gain of ten. Stage Q13 of the differential amplifier receives a negative voltage from the applicable voltage divider when S2 is in one of the voltage positions while stage Q11 is connected to the +S (common) terminal. With S2 in a current position, stage Q11 receives a positive voltage from the applicable voltage divider while stage Q13 is connected to the +S terminal. The differential output of the amplifier is taken from the collectors of Q12 and Q14. Transistor Q15 is a constant current source which sets up the proper bias current for the amplifier. Potentiometer R63 permits zeroing of the meter. The meter amplifier stage contains an inherent current limiting feature which protects the meter movement against overloads. For example, if METER switch S2 is placed in position A11, (low current range) when the power supply is actually delivering a higher Ampere output, the differential amplifiers are quickly driven into saturation; limiting the current through the meter to a safe value.

4-50 Figures 4-5 and 4-6 show the meter connections when S2 is in the higher voltage and current positions, respectively. For the sake of simplicity, some of the actual circuit components are not shown on these drawings. With METER switch S2 in the higher voltage range, position (2), the voltage drop across R59 is the input to the meter amplifier and

the meter indicates the output voltage across the +S and -S terminals. For low output voltages, S2 can be switched to position (1) resulting in the application of a larger percentage of the output voltage (drop across R59 and R60) to the meter amplifier.

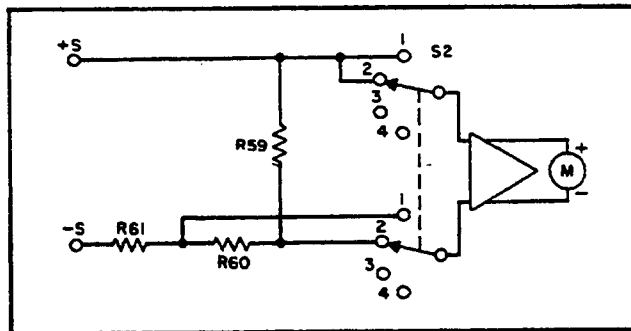

Figure 4-5. Voltmeter Connections, Simplified Schematic

4-51 With S2 in the higher current range position (Figure 4-6) the voltage drop across R58 is applied to the meter amplifier and the meter indicates the output current which flows through R54. For low values of output current, S2 can be switched to position (4) and the voltage drop across R57 and R58 is applied to the meter amplifier.

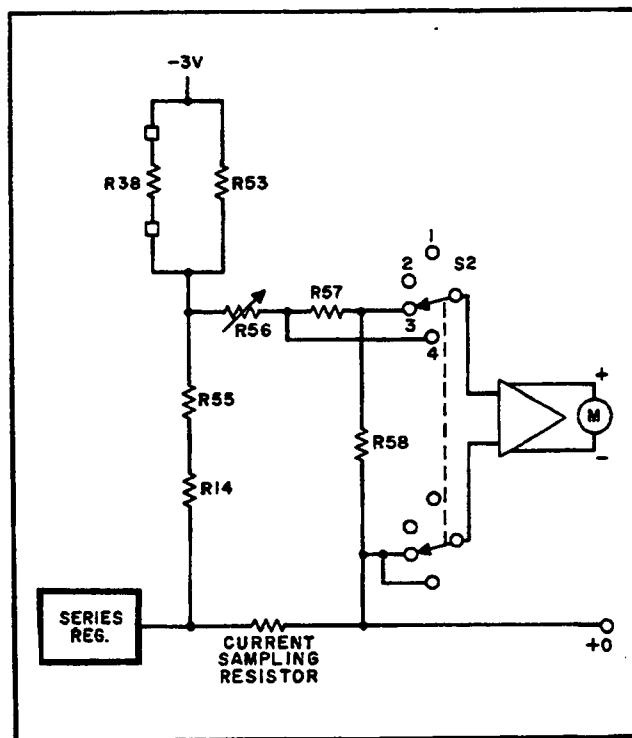

Figure 4-6. Ammeter Connections, Simplified Schematic

4-52 The -3 Volt bias source provides an offset current to the meter circuit which compensates for the programming current that flows through the current sampling resistance. Resistor R38, mounted on stand-offs, is selected so that the offset current bucks out the programming current, allowing the ammeter to be zeroed.

4-53 ADDITIONAL PROTECTION FEATURES

4-54 The supply has several "special purpose" components which protect the supply in the event

of unusual circumstances. One of these components is CR34 which is connected across the output terminals of the supply and prevents internal damage from reverse voltage that might be applied across the supply. This could occur, for example, during Auto-Series operation, if one supply were turned on before the other.

4-55 Zener diode, VR3, connected across the series regulator and R54, protects Q6 from the effects of reverse voltages.

SECTION V MAINTENANCE

5-1 INTRODUCTION

5-2 Upon receipt of the power supply, the performance check (Paragraph 5-5) should be made. This check is suitable for incoming inspection. If a fault is detected in the power supply while making the performance check or during normal operation, proceed to the troubleshooting procedures (Paragraph 5-51). After troubleshooting and repair (Paragraph 5-67), perform any necessary adjustments and calibrations (Paragraph 5-69). Before returning the power

supply to normal operation, repeat the performance check to ensure that the fault has been properly corrected and that no other faults exist. Before doing any maintenance checks, turn-on power supply, allow a half-hour warm-up.

5-3 TEST EQUIPMENT REQUIRED

5-4 Table 5-1 lists the test equipment required to perform the various procedures described in this Section.

Table 5-1. Test Equipment Required

TYPE	REQUIRED CHARACTERISTICS	USE	RECOMMENDED MODEL
Differential Voltmeter	Sensitivity: 1mV full scale (min.). Input impedance: 10 megohms (min.).	Measure dc voltages; calibration procedures	Ⓢ 3420 (See Note)
Variable Voltage Transformer	Range: 90-130 Volts. Equipped with voltmeter accurate within 1V.	Vary ac input	----
AC Voltmeter	Accuracy: 2%. Sensitivity: 1mV full scale deflection (min.).	Measure ac voltages and ripple	Ⓢ 403B
Oscilloscope	Sensitivity: 100 μ V/cm. Differential input.	Display transient response waveforms	Ⓢ 140A plus 1400A plug in.
Oscillator	Range: 5Hz to 600KHz. Accuracy: 2%.	Impedance checks	Ⓢ 200CD
DC Voltmeter	Accuracy: 1%. Input resistance: 20,000 ohms/Volt (min.).	Measure dc voltages	Ⓢ 412A
Repetitive Load Switch	Rate: 60-400Hz, 2 μ sec rise and fall time.	Measure transient response	See Figure 5-6.
Resistor	6207B - 793 Ω \pm 10% (35W min.). 6209B - 3185 Ω \pm 10% (35W min.).	Load resistor	----
Resistor	6207B - 7.5 Ω \pm 1% 3 Watts 6209B - 15 Ω \pm 1% 1.5 Watts	Current sampling	See R54 in Section VI
Resistor	1K Ω \pm 1%, 2 Watts non-inductive.	Measure impedance	----
Resistor	100 ohms, \pm 5%, 10 Watts.	Measure impedance	----

Table 5-1. Test Equipment Required (Continued)

TYPE	REQUIRED CHARACTERISTICS	USE	RECOMMENDED MODEL
Resistor	Value: See Paragraph 5-78. ±0.1%, 5 Watts.	Calibrate programming current	----
Resistor	Value: See Paragraph 5-81. ±0.1%, 5 Watts.	Calibrate programming current	----
Capacitor	500µf, 50W Vdc.	Measure impedance	----
Decade Resistance Box	Range: 0-150K (min.). Accuracy: 0.1% plus 1 ohm. Make-before-break contacts.	Measure programming coefficients	----

NOTE

A satisfactory substitute for a differential voltmeter is to arrange a reference voltage source and null detector as shown in Figure 5-1. The reference voltage source is adjusted so that the voltage difference between the supply being measured and the reference voltage will have the required resolution for the measurement being made. The voltage difference will be a function of the null detector that is used. Examples of satisfactory null detectors are: HP 419A null detector, a dc coupled oscilloscope utilizing differential input, or a 50mV meter movement with a 100 division scale. For the latter, a 2mV change in voltage will result in a meter deflection of four divisions.

CAUTION

Care must be exercised when using an electronic null detector in which one input terminal is grounded to avoid ground loops and circulating currents.

5-5 PERFORMANCE TEST

5-6 The following test can be used as an incoming inspection check and appropriate portions of the test can be repeated either to check the operation of the instrument after repairs or for periodic maintenance tests. The tests are performed using a 115 Vac 60Hz, single phase input power source. If the correct result is not obtained for a particular check, do not adjust any controls; proceed to troubleshooting (Paragraph 5-51).

5-7 CONSTANT VOLTAGE TESTS

5-8 The measuring device must be connected across the sensing leads of the supply or as close to the output terminals as possible when measuring the output impedance, transient response, regulation, or ripple of the power supply in order to achieve valid measurements. A measurement made across the load includes the impedance of the leads to the load and such lead lengths can easily have an impedance several orders of magnitude greater than the supply impedance, thus invalidating the measurement.

5-9 The monitoring device should be connected to the +S and -S terminals (see Figure 3-2) or as shown in Figure 5-2. The performance characteristics should never be measured on the front terminals if the load is connected across the rear terminals. Note that when measurements are made at the front terminals, the monitoring leads are connected at A, not B, as shown in Figure 5-2. Failure to connect

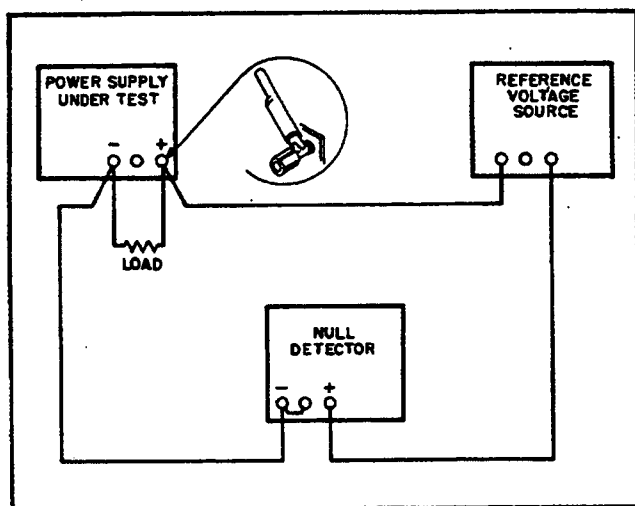

Figure 5-1. Differential Voltmeter Substitute, Test Setup

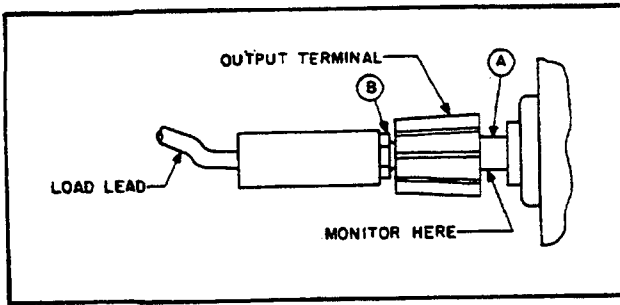

Figure 5-2. Front Panel Terminal Connections

the measuring device at A will result in a measurement that includes the resistance of the leads between the output terminals and the point of connection.

5-10 Voltage Rated Output and Meter Accuracy.
Proceed as follows:

- a. Connect load resistor across rear output terminals of supply. Resistor value is 800 ohms for Model 6207B or 3200 ohms for Model 6209B.
- b. Connect differential voltmeter across +S and -S terminals of supply observing correct polarity.
- c. Set METER switch to highest voltage range and turn on supply.
- d. Adjust VOLTAGE control until front panel meter indicates exactly the maximum rated output voltage.
- e. Differential voltmeter should indicate maximum rated output voltage within $\pm 3\%$.

5-11 Load Regulation.

Definition: The change ΔE_{OUT} in the static value of dc output voltage resulting from a change in load resistance from open circuit to a value which yields maximum rated output current (or vice versa).

5-12 To check the constant voltage load regulation, proceed as follows:

- a. Connect test setup shown in Figure 5-3.
- b. Turn CURRENT controls fully clockwise.
- c. Set METER switch to highest current range and turn on supply.
- d. Adjust VOLTAGE control until front panel meter indicates exactly the maximum rated output voltage.
- e. Read and record voltage indicated on differential voltmeter.
- f. Disconnect load resistors.
- g. Reading on differential voltmeter should not vary from reading recorded in step (e) by more than the following:

Model No.	6207B	6209B
Variation (mVdc)	± 34	± 66

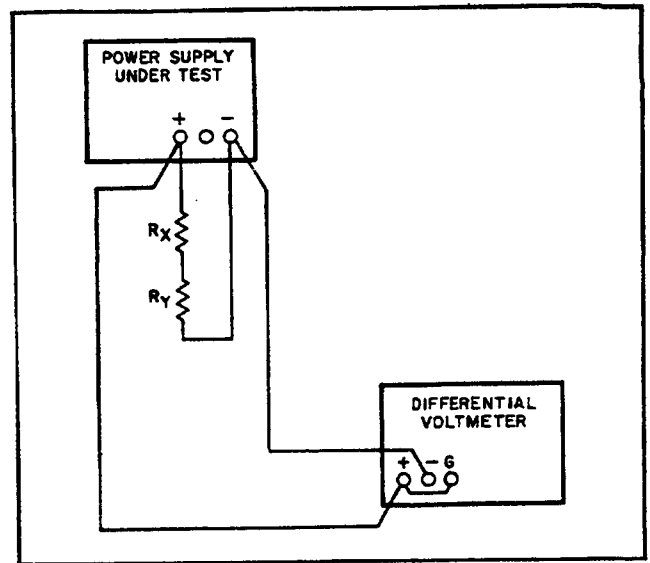

Figure 5-3. Load Regulation, Constant Voltage

5-13 Line Regulation.

Definition: The change, ΔE_{OUT} in the static value of dc output voltage resulting from a change in ac input voltage over the specified range from low line 10% less than nominal to high line 10% more than nominal or from high line to low line.

5-14 To check the line regulation, proceed as follows:

- a. Connect variable auto transformer between input power source and power supply power input.
- b. Turn CURRENT controls fully clockwise.
- c. Connect test setup shown in Figure 5-3.
- d. Adjust variable auto transformer for 105V ac input.
- e. Set METER switch to highest voltage range and turn on supply.
- f. Adjust VOLTAGE control until front panel meter indicates exactly the maximum rated output voltage.
- g. Read and record voltage indicated on differential voltmeter.
- h. Adjust variable auto transformer for 125V ac input.
- i. Reading on differential voltmeter should not vary from reading recorded in step (g) by more than the following:

Model No.	6207B	6209B
Variation (mVdc)	± 34	± 66

5-15 Ripple and Noise.

Definition: The residual ac voltage which is superimposed on the dc output of a regulated power supply. Ripple and noise may be specified and measured in terms of its RMS or (preferably) peak-to-peak value.

Ripple and noise measurement can be made at any input ac line voltage combined with any dc output voltage and load current within rating.

5-16 The amount of ripple and noise that is present on the power supply output is measured either in terms of the RMS or (preferably) peak-to-peak value. The peak-to-peak measurement is particularly important for applications where noise spikes could be detrimental to a sensitive load, such as logic circuitry. The RMS measurement is not an ideal representation of the noise, since fairly high output noise spikes of short duration could be present in the ripple and not appreciably increase the RMS value.

5-17 The technique used to measure high frequency noise or "spikes" on the output of a power supply is more critical than the low frequency ripple and noise measurement technique; therefore the former is discussed separately in Paragraph 5-25.

5-18 Ripple and Noise Measurements. Figure 5-4A shows an incorrect method of measuring p-p ripple. Note that a continuous ground loop exists from the third wire of the input power cord of the supply to the third wire of the input power cord of the oscilloscope via the grounded power supply case, the wire between the negative output terminal of the power supply and the vertical input of the scope, and the grounded scope case. Any ground current circulating in this loop as a result of the difference in potential E_G between the two ground points causes an IR drop which is in series with the scope input. This IR drop, normally having a 60Hz line frequency fundamental, plus any pickup on the unshielded leads interconnecting the power supply and scope, appears on the face of the CRT. The magnitude of this resulting noise signal can easily be much greater than the true ripple developed between the plus and minus output terminals of the power supply, and can completely invalidate the measurement.

5-19 The same ground current and pickup problems can exist if an RMS voltmeter is substituted in place of the oscilloscope in Figure 5-4. However, the oscilloscope display, unlike the true RMS meter reading, tells the observer immediately whether the fundamental period of the signal displayed is 8.3 milliseconds (1/120Hz) or 16.7 milliseconds (1/60Hz). Since the fundamental ripple frequency present on the output of an ϕ supply is 120Hz (due to full-wave rectification), an oscilloscope display showing a 120Hz fundamental component is indicative of a "clean" measurement setup, while the presence of a 60Hz fundamental usually means that an improved setup will result in a more accurate (and lower) value of measured ripple.

5-20 Figure 5-4B shows a correct method of measuring the output ripple of a constant voltage power supply using a single-ended scope. The ground loop path is broken by floating the power supply output. Note that to ensure that no potential difference exists between the supply and the oscilloscope, it is recommended that whenever possible they be plugged into the same ac power buss. If the same buss cannot be used, both ac grounds must be at earth ground potential.

5-21 Either a twisted pair or (preferably) a shielded two-wire cable should be used to connect the output terminals of the power supply to the vertical input terminals of the scope. When using a twisted pair, care must be taken that one of the two wires is connected to the grounded input terminal of the oscilloscope. When using shielded two-wire, it is essential for the shield to be connected to ground at one end only so that no ground current will flow through this shield, thus inducing a noise signal in the shielded leads.

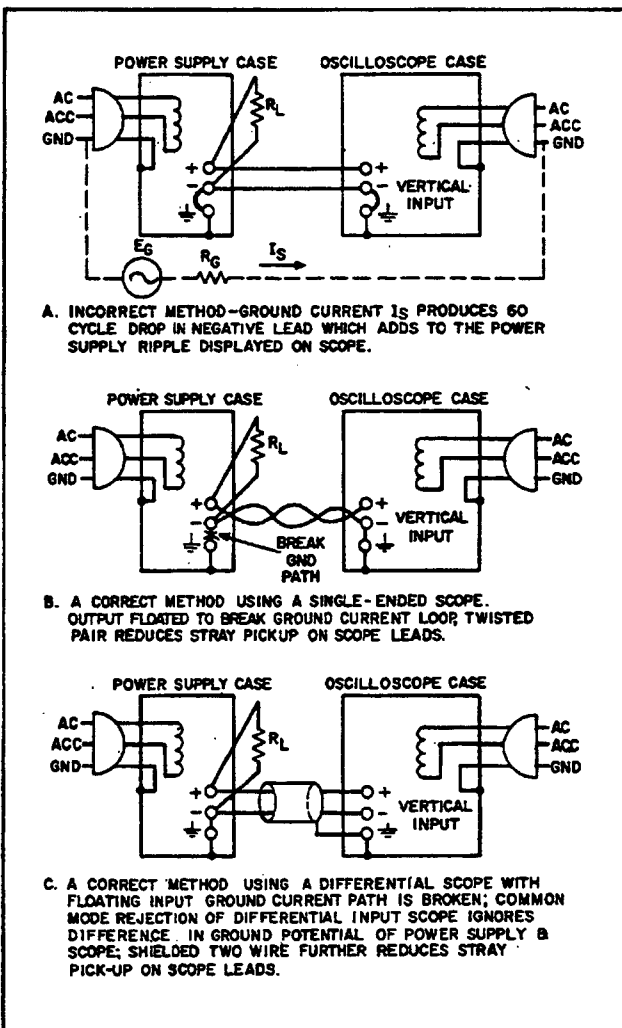

Figure 5-4. Constant Voltage Ripple and Noise, Test Setup

5-22 To verify that the oscilloscope is not displaying ripple that is induced in the leads or picked up from the grounds, the (+) scope lead should be shorted to the (-) scope lead at the power supply terminals. The ripple value obtained when the leads are shorted should be subtracted from the actual ripple measurement.

5-23 In most cases, the single-ended scope method of Figure 5-4B will be adequate to eliminate non-real components of ripple and noise so that a satisfactory measurement may be obtained. However, in more stubborn cases it may be necessary to use a differential scope with floating input as shown in Figure 5-4C. If desired, two single conductor shielded cables may be substituted in place of the shielded two-wire cable with equal success. Because of its common mode rejection, a differential oscilloscope displays only the difference in signal between its two vertical input terminals, thus ignoring the effects of any common mode signal introduced because of the difference in the ac potential between the power supply case and scope case. Before using a differential input scope in this manner, however, it is imperative that the common mode rejection capability of the scope be verified by shorting together its two input leads at the power supply and observing the trace on the CRT. If this trace is a straight line, the scope is properly ignoring any common mode signal present. If this trace is not a straight line, then the scope is not rejecting the ground signal and must be realigned in accordance with the manufacturer's instructions until proper common mode rejection is attained.

5-24 To check the ripple and noise output, proceed as follows:

- a. Connect the oscilloscope or RMS voltmeter as shown in Figures 5-4B or 5-4C.
- b. Adjust VOLTAGE control until front panel meter indicates maximum rated output voltage.
- c. The observed ripple and noise should be less than $500\mu\text{V}_{\text{rms}}$ and 50mV p-p .

5-25 Noise Spike Measurement. When a high frequency spike measurement is being made, an instrument of sufficient bandwidth must be used; an oscilloscope with a bandwidth of 20MHz or more is adequate. Measuring noise with an instrument that has insufficient bandwidth may conceal high frequency spikes detrimental to the load.

5-26 The test setups illustrated in Figures 5-4A and 5-4B are generally not acceptable for measuring spikes; a differential oscilloscope is necessary. Furthermore, the measurement concept of Figure 5-4C must be modified if accurate spike measurement is to be achieved:

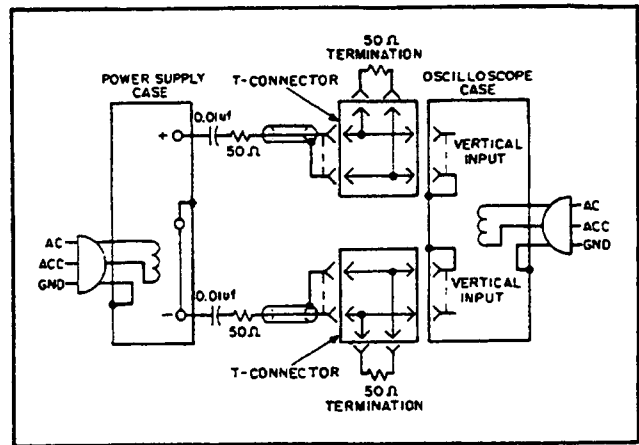

Figure 5-5. CV Noise Spike, Test Setup

1. As shown in Figure 5-5, two coax cables, must be substituted for the shielded two-wire cable.
2. Impedance matching resistors must be included to eliminate standing waves and cable ringing, and the capacitors must be connected to block the dc current path.
3. The length of the test leads outside the coax is critical and must be kept as short as possible; the blocking capacitor and the impedance matching resistor should be connected directly from the inner conductor of the cable to the power supply terminals.
4. Notice that the shields of the power supply end of the two coax cables are not connected to the power supply ground, since such a connection would give rise to a ground current path through the coax shield, resulting in an erroneous measurement.
5. Since the impedance matching resistors constitute a 2-to-1 attenuator—the noise spikes observed on the oscilloscope should be less than 20mV p-p instead of 40mV p-p .

5-27 The circuit of Figure 5-5 can also be used for the normal measurement of low frequency ripple and noise; simply remove the four terminating resistors and the blocking capacitors and substitute a higher gain vertical plug-in in place of the wideband plug-in required for spike measurements. Notice that with these changes, Figure 5-5 becomes a two-cable version of Figure 5-4C.

5-28 Transient Recovery Time.

Definition: The time "X" for output voltage recovery to within "Y" millivolts of the nominal output voltage following a "Z" Amp step change in load current — where: "Y" is specified as 10 millivolts. The nominal output voltage is defined as the dc level half way between the static output voltage before and after the imposed load change. "Z" is the specified load current change, which is 5 Amperes.

5-29 A mercury-wetted relay, as connected in the load switching circuit of Figure 5-6 should be used for loading and unloading the supply. When this load switch is connected to a 60Hz ac input, the mercury-wetted relay will open and close 60 times per second. Adjustment of the 25K control permits adjustment of the duty cycle of the load current switching and reduction in jitter of the oscilloscope display.

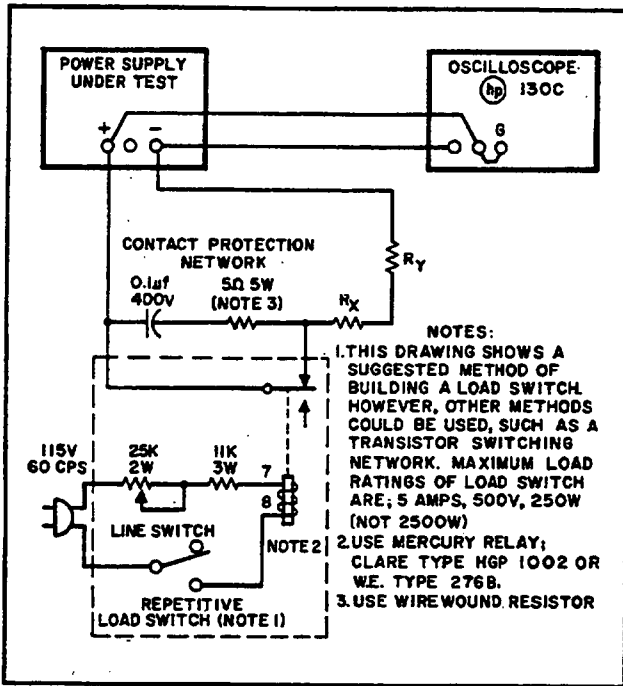

Figure 5-6. Transient Recovery Time, Test Setup

5-30 The maximum load ratings listed in Figure 5-6 must be observed in order to preserve the mercury-wetted relay contacts. Switching of larger load currents can be accomplished with mercury pool relays; with this technique fast rise times can still be obtained, but the large inertia of mercury pool relays limits the maximum repetition rate of load switching and makes the clear display of the transient recovery characteristic on an oscilloscope more difficult.

5-31 To check the transient recovery time, proceed as follows:

- Connect test setup shown in Figure 5-6.
- Turn CURRENT controls fully clockwise.
- Turn on supply and adjust voltage controls until front panel ammeter indicates exactly 5 Amperes.
- Close the line switch on the repetitive load switch setup.
- Set the oscilloscope for internal sync and lock on either the positive or negative load transient spike.

f. Set the vertical input of the oscilloscope for ac coupling so that small dc level changes in the output voltage of the power supply will not cause the display to shift.

g. Adjust the sync controls separately for the positive and negative going transients so that not only the recovery waveshape but also as much as possible of the rise time of the transient is displayed.

h. Starting from the major graticule division representative of time zero, count to the right 50µ sec and vertically 10mV. Recovery should be within these tolerances as illustrated in Figure 5-7.

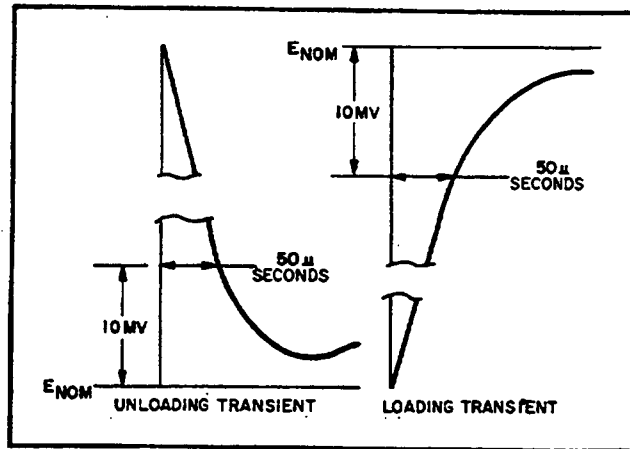

Figure 5-7. Transient Recovery Time, Waveforms

5-32 OUTPUT IMPEDANCE

5-33 To check the output impedance, proceed as follows:

- Connect test setup shown in Figure 5-8.

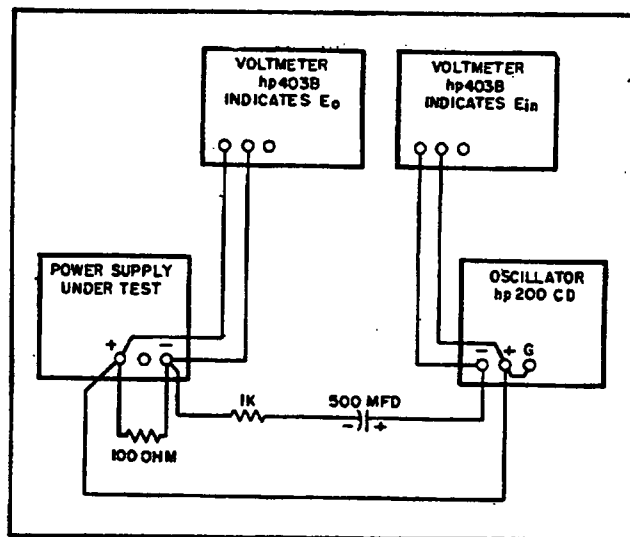

Figure 5-8. Output Impedance, Test Setup

- b. Set METER switch to highest voltage range and turn on supply.
- c. Adjust VOLTAGE control until front panel meter reads 20 Volts.
- d. Set AMPLITUDE control on Oscillator to 10 Volts (E_{in}), and FREQUENCY control to 100Hz.
- e. Record voltage across output terminals of the power supply (E_o) as indicated on ac voltmeter.
- f. Calculate the output impedance by the following formula: $Z_{out} = E_o R / (E_{in} - E_o)$.
 E_o = rms voltage across power supply output terminals.
 $R = 1000$
 $E_{in} = 10$ Volts.
- g. The output impedance (Z_{out}) should be less than 0.020 ohms.
- h. Using formula of Step (f), calculate output impedance at frequencies of 50KHz and 500KHz. Values should be less than 0.5 ohm and 3.0 ohms, respectively.

5-34 Temperature Coefficient.

Definition: The change in output voltage per degree centigrade change in the ambient temperature under conditions of constant input ac line voltage, output voltage setting, and load resistance.

5-35 The temperature coefficient of a power supply is measured by placing the power supply in an oven and varying it over any temperature span within its rating. (Most power supplies are rated for operation from 0°C to 55°C.) The power supply must be allowed to thermally stabilize for a sufficient period of time at each temperature of measurement.

5-36 The temperature coefficient specified is the maximum temperature-dependent output voltage change which will result over any 5°C interval. The differential voltmeter or digital voltmeter used to measure the output voltage change of the supply should be placed outside the oven and should have a long term stability adequate to insure that its drift will not affect the overall measurement accuracy.

5-37 To check the temperature coefficient, proceed as follows:

- a. Connect test setup shown in Figure 5-3.
- b. Turn CURRENT controls fully clockwise and adjust front panel VOLTAGE controls until the front panel voltmeter indicates maximum rated output voltage.
- c. Insert the power supply into the temperature-controlled oven (differential voltmeter and load resistance remain outside oven). Set the temperature to 30°C and allow 30 minutes warm-up.
- d. Record differential voltmeter indication.
- e. Raise the temperature to 40°C and allow 30 minutes warm-up.
- f. The differential voltmeter indication should change by less than 330mV (660mV for Model 6209B) from indication recorded in Step (d).

5-38 Output Stability.

Definition: The change in output voltage for the first eight hours following a 30 minute warm-up period. During the interval of measurement all parameters, such as load resistance, ambient temperature, and input line voltage are held constant.

5-39 This measurement is made by monitoring the output of the power supply on a differential voltmeter or digital voltmeter over the stated measurement interval; a strip chart recorder can be used to provide a permanent record. A thermometer should be placed near the supply to verify that the ambient temperature remains constant during the period of measurement. The supply should be put in a location immune from stray air currents (open doors or windows, air conditioning vents); if possible, the supply should be placed in an oven which is held at a constant temperature. Care must be taken that the measuring instrument has a stability over the eight hour interval which is at least an order of magnitude better than the stability specification of the power supply being measured. Typically, a supply may drift less over the eight hour measurement interval than during the ½ hour warm-up period.

5-40 Stability measurement can be made while the supply is remotely programmed with a fixed wire-wound resistor, thus avoiding accidental changes in the front panel setting due to mechanical vibration or "knob-twiddling".

5-41 To check the output stability, proceed as follows:

- a. Connect test setup shown in Figure 5-3.
- b. Turn CURRENT controls fully clockwise and adjust VOLTAGE controls for 160Vdc output (320Vdc for Model 6209B).
- c. Allow 30 minutes warm-up then record the differential voltmeter indication.
- d. After 8 hours, differential voltmeter should change by less than 165mV (325mV for Model 6209B) from indication recorded in Step (c).

5-42 CONSTANT CURRENT TESTS

5-43 For output current measurements, the current sampling resistor must be treated as a four terminal device. In the manner of a meter shunt, the load current is fed to the extremes of the wire leading to the resistor while the sampling terminals are located as close as possible to the resistance portion itself (see Figure 5-9). Generally, any current sampling resistor should be of the low noise, low temperature coefficient (less than 30ppm/°C) type and should be used at no more than 5% of its rated power so that its temperature rise will be minimized. The latter, reduces resistance changes due to thermal fluctuations.

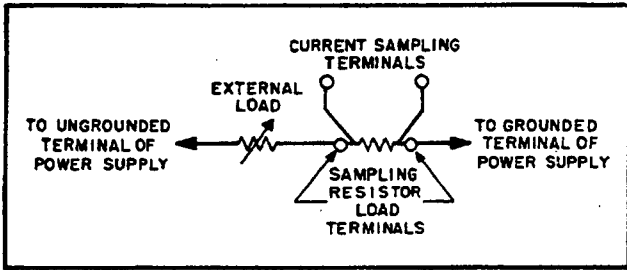

Figure 5-9. Output Current Measurement Technique

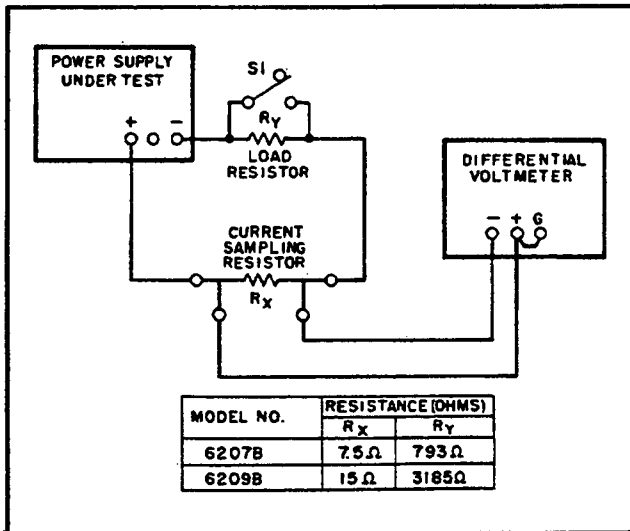

Figure 5-10. Output Current, Test Setup

5-44 Current Output and Ammeter Accuracy. Proceed as follows:

- Connect test setup shown in Figure 5-10, leaving switch S1 open.
- Turn CURRENT controls fully clockwise.
- Set METER switch to highest current range and turn on supply.
- Adjust VOLTAGE control until front panel meter indicates exactly the maximum rated output current.
- Differential voltmeter should read 1.5Vdc \pm 45mVdc.

5-45 Load Regulation.

Definition: The change, ΔI_{OUT} , in the static value of dc output current resulting from a change in load resistance from short circuit to a value which gives maximum rated output voltage (or vice versa).

5-46 To check the load regulation, proceed as follows:

- Connect test setup shown in Figure 5-10.
- Turn VOLTAGE control fully clockwise.
- Set METER switch to highest current range and turn on supply.

- Adjust CURRENT controls until front panel meter reads exactly the maximum rated output current.
- Read and record voltage indicated on differential voltmeter.
- Short out load resistor (R_y) by closing switch S1.
- Reading on differential voltmeter should not vary from reading recorded in Step (e) by more than 34mVdc for Model 6207B and 66mVdc for 6209B.

5-47 Line Regulation.

Definition: The change, ΔI_{OUT} , in the static value of dc output current resulting from a change in ac input voltage over the specified range from low line (10% below nominal) to high line (10% above nominal) or from high line to low line.

5-48 To check the line regulation, proceed as follows:

- Utilize test setup shown in Figure 5-10, leaving switch S1 open throughout test.
- Connect variable auto transformer between input power source and power supply power input.
- Adjust auto transformer for 105Vac input.
- Turn VOLTAGE control(s) fully clockwise.
- Set METER switch to highest current range and turn on supply.
- Adjust CURRENT controls until front panel meter reads exactly the maximum rated output current.
- Read and record voltage indicated on differential voltmeter.
- Adjust variable auto transformer for 125Vac input.
- Reading on differential voltmeter should not vary from reading recorded in Step (g) by more than 34mVdc for 6207B and 66mVdc for 6209B.

5-49 Ripple and Noise. Most of the instructions pertaining to the ground loop and pickup problems associated with constant voltage ripple and noise measurement also apply to the measurement of constant current ripple and noise. Figure 5-11 illustrates the most important precautions to be observed when measuring the ripple and noise of a constant current supply. The presence of a 120Hz waveform on the oscilloscope is normally indicative of a correct measurement method. A waveshape having 60Hz as its fundamental component is typically associated with an incorrect measurement setup.

5-50 Ripple and Noise Measurement. To check the ripple and noise, proceed as follows:

- Connect the oscilloscope or RMS voltmeter as shown in Figures 5-11B or 5-11C.
- Rotate the VOLTAGE controls fully clockwise.
- Turn on supply and adjust CURRENT controls until front panel meter reads exactly the maximum rated output current.

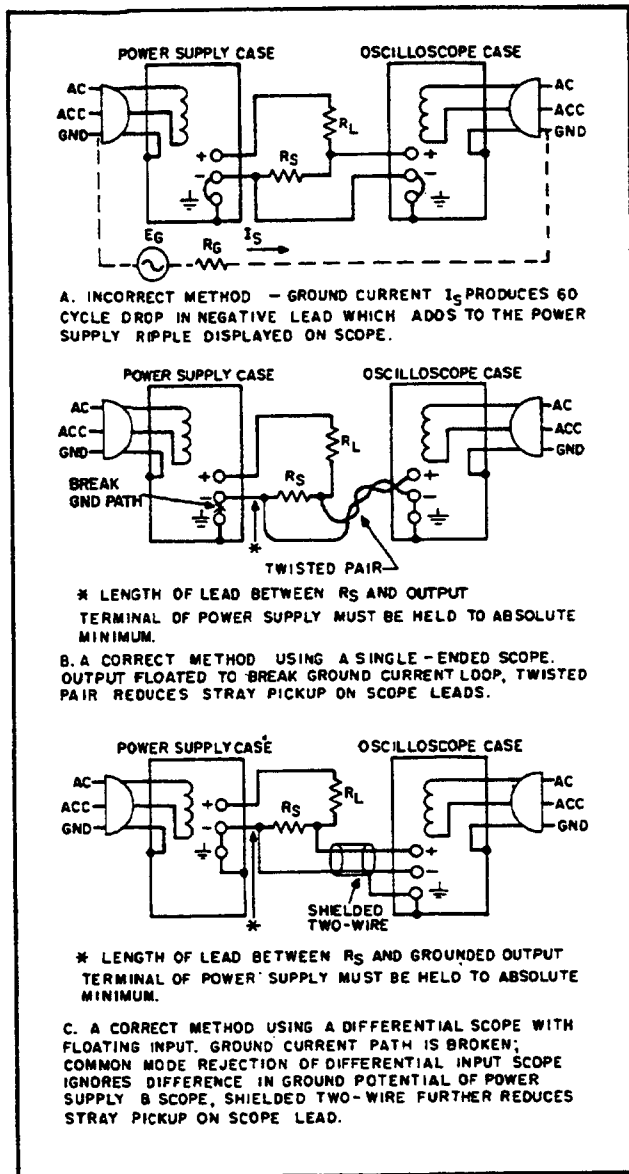

Figure 5-11. CC Ripple and Noise, Test Setup

d. The ripple and noise indication should be less than 1.5mVrms for Model 6207B and 3mVrms for Model 6209B.

5-51 TROUBLESHOOTING

5-52 Components within Hewlett-Packard power supplies are conservatively operated to provide maximum reliability. In spite of this, parts within a supply may fail. Usually the instrument must be immediately repaired with a minimum of "down time" and a systematic approach as outlined in succeeding paragraphs can greatly simplify and speed up the repair.

5-53 Before attempting to troubleshoot this instrument, ensure that the fault is with the instrument

and not with an associated circuit. The performance test (Paragraph 5-5) enables this to be determined without having to remove the instrument from the cabinet.

5-54 A good understanding of the principles of operation is a helpful aid in troubleshooting, and it is recommended that the reader review Section IV of the manual before attempting to troubleshoot the unit in detail. Once the principles of operation are understood, refer to the overall troubleshooting procedures in Paragraph 5-57 to locate the symptom and probable cause.

5-55 The schematic diagram at the rear of the manual (Figure 7-1) contains normal voltage readings taken at various points within the circuits. These voltages are positioned adjacent to the applicable test points (identified by encircled numbers). Component and test point designations are marked directly on the main printed wiring board.

5-56 If a defective component is located, replace it and re-conduct the performance test. When a component is replaced, refer to the repair and replacements and adjustment and calibration paragraphs in this section.

5-57 OVERALL TROUBLESHOOTING PROCEDURE

5-58 To locate the cause of trouble, follow Steps 1, 2, and 3 in sequence.

(1) Check for obvious troubles such as open fuse, defective power cord, input power failure, or defective voltage or current meter. Next remove the top and bottom covers (each held by four retaining screws) and inspect for open connections, charred components, etc. If the trouble source cannot be detected by visual inspection, proceed with Step 2.

(2) In almost all cases, the trouble can be caused by improper dc bias or reference voltages; thus, it is a good practice to check voltages in Table 5-2 before proceeding with Step 3.

(3) Disconnect the load and examine Table 5-2 to determine your symptom and probable cause.

5-59 Reference Circuit.

- Make an ohmmeter check to be certain that neither the positive nor negative output terminal is grounded.
- Turn front panel VOLTAGE and CURRENT controls fully clockwise (maximum).
- Turn on power supply (no load connected).
- Proceed as instructed in Table 5-2.

5-60 To check the Zener diodes in the reference circuit, proceed as follows:

- Connect differential voltmeter across Zener diode (VR1 or VR2).
- Connect appropriate load resistor, given in Figure 5-10, across (+) and (-) output terminals.

- c. Turn VOLTAGE control fully clockwise.
- d. Set METER switch to highest current range and turn on supply.
- e. Adjust CURRENT controls until panel meter reads exactly the maximum rated output current.
- f. Read and record voltage indicated on differential voltmeter.
- g. Short out load resistor by closing S1.
- h. If reading on differential voltmeter differs by more than 1.26mV from the reading in Step (f), replace Zener diode.

5-61 REGULATING LOOP TROUBLES

5-62 If the voltages in Table 5-2 have been checked to eliminate the reference and bias circuits as a source of trouble; the malfunction is caused by either the series regulator or preregulator feedback loop. Because the interaction between these two loops make logical troubleshooting difficult, the following steps are provided to temporarily separate the action of the two feedback loops. Once the loops are separated, the operation of either loop can be analyzed independently. This method should be followed whenever a high or low output voltage condition exists and when troubleshooting gets beyond the "quick and easy stage".

- a. Disconnect the gate leads from SCR CR35.
- b. Connect a small dc power supply across the input capacitor C14. A 0-20 Volt, 0.2 Ampere, supply is adequate.
- c. Turn on the power supply and, with no load connected, set the external voltage source to 100 Volts. To verify the operation of the series regulator loop, vary the front panel voltage control. The output voltage of the supply should be variable between 0 and about 90 Volts (approximately 10V is dropped across the series regulator). If this is the case, the series regulator feedback loop is operating normally and the trouble condition is probably due to a defect in the preregulator feedback loop (refer to Table 5-6). If the output voltage remains

in the low or high stage, and varying the voltage control has little or no effect, then the trouble is probably in the series regulator feedback loop. Refer to Table 5-4 (high output) or Table 5-5 (low output).

5-63 After the trouble has been isolated to one of the feedback loops, troubleshooting can proceed as described in Tables 5-4, 5-5, or 5-6. After both loops are operating in a satisfactory manner, the external power supply should be removed and the SCR gate lead reconnected.

5-64 Series Regulating Feedback Loop. When troubleshooting the series regulating loop, it is useful to open the loop since measurements made anywhere within a closed loop may appear abnormal. With a loop closed, it is very difficult to separate cause from effect. As described in Tables 5-4 and 5-5, the conduction or cutoff capability of each stage is checked by shorting or opening a previous stage, as follows:

- a. Shorting the emitter to collector of a transistor simulates saturation, or the full ON condition.
- b. Shorting the emitter to base of a transistor cuts it off, and simulates an open circuit between emitter and collector.

5-65 Although a logical first choice might be to break the loop somewhere near its mid-point, and then perform successive subdividing tests, it is more useful to trace the loop from the series regulator backwards a stage at a time, since loop failures occur more often at the higher power levels.

5-66 Preregulator Feedback Loop. The preregulator feedback loop (SCR control circuit) can be conveniently checked by observing the waveforms given on the schematic at the rear of the manual. As indicated in Table 5-6, the control circuit is checked by starting with the output waveform and tracing backwards from this point.

Table 5-2. Reference Circuit Troubleshooting

STEP	METER COMMON	METER POSITIVE	NORMAL INDICATION	NORMAL RIPPLE (P-P)	IF INDICATION ABNORMAL, TAKE THIS ACTION
1	+S	33	$6.2 \pm 0.3\text{Vdc}$	2mV	Check 12.4 Volt bias or VR1. (Refer to Paragraph 5-60.)
2	31	+S	$6.2 \pm 0.3\text{Vdc}$	2mV	Check 12.4 Volt bias or VR2. (Refer to Paragraph 5-60.)
3	+S	37	$12.4 \pm 1.0\text{Vdc}$	4mV	Check Q8, Q9, CR22, CR23, C10, T3.

Table 5-3. Overall Troubleshooting

SYMPTOM	CHECKS AND PROBABLE CAUSES
High Output Voltage	a. Check series regulator feedback loop or preregulator feedback loop. Refer to Paragraph 5-62 and then Table 5-4 or 5-6 as instructed.
Low or No Output Voltage	a. If output is zero, check fuse. b. Check series regulator feedback or preregulator feedback loop. Refer to Paragraph 5-62 and then Table 5-5 or 5-6 as instructed.
High Ripple	a. Check operating setup for ground loops. b. If output floating, connect 1 μ f capacitor between output and ground. c. Ensure that supply is not crossing over to constant current mode under loaded conditions. d. Check for low voltage across C14 or Q6. e. Check for excessive ripple on reference voltages. (Table 5-2)
Poor Line Regulation	a. Check reference circuit (Paragraph 5-59). b. Supply current limiting. c. Check reference circuit adjustment (Paragraph 5-83).
Poor Load Regulation (Constant Voltage)	a. Measurement technique (Paragraph 5-11). b. Check reference circuit (Paragraph 5-59, VR1). c. Ensure that supply is not going into current limit. Check constant current input circuit.
Poor Load Regulation (Constant Current)	a. Check reference circuit (Paragraph 5-59, VR2) and adjustment (Paragraph 5-83). b. C19, C20, and CR34 leaky. c. Check clamp circuit Q10, CR30, VR5, and CR32. d. Ensure that supply is not crossing over to constant voltage operation. Check constant voltage comparator circuit.
Oscillates (Constant Voltage/Constant Current)	a. Check C5 for open, adjustment of R30 (Paragraph 5-86). b. Check R20, C3 in constant current comparator circuit. c. Check CR19 and C26 in SCR control circuit.
Poor Stability (Constant Voltage)	a. Check ± 6.2 Vdc reference voltages (Paragraph 5-60). (VR1 and VR2.) b. Noisy programming resistor R10. c. CR1, CR2 leaky. d. Check R1, R12, R13, C2 for noise or drift. e. Stage Q1 defective.
Poor Stability (Constant Current)	a. Check ± 6.2 Vdc reference voltages (Paragraph 5-60). (VR1 and VR2.)

Table 5-3. Overall Troubleshooting (Continued)

SYMPTOM	CHECKS AND PROBABLE CAUSES
Poor Stability (Constant Current) Continued	b. Noisy programming resistor R16. c. CR5, CR34, C20, C3 leaky. d. Check R18, R19, R20, R21, R54 for noise or drift. e. Stage Q2 defective.

Table 5-4. High Output Voltage Troubleshooting

STEP	ACTION	RESPONSE	PROBABLE CAUSE
1	Check turn off of Q6 by shorting Q4 emitter to collector.	a. Output voltage remains high. b. Output voltage decreases.	a. Q6 shorted, VR3 shorted. b. Remove short and proceed to Step 2.
2	Check turn on of Q4 by opening the emitter of Q3.	a. Output voltage remains high. b. Output voltage decreases.	a. Q4 open. b. Reconnect lead and proceed to Step 3.
3	Check turn off of Q3 by disconnecting collector lead of Q1A.	a. Output voltage remains high. b. Output voltage decreases.	a. Q3 shorted. Q17 defective. b. Q1A shorted. Q1B open. Check for open strap between A6 and A8. Check R10 for open.

Table 5-5. Low Output Voltage Troubleshooting

STEP	ACTION	RESPONSE	PROBABLE CAUSE
1	Check turn on of Q6 by disconnecting emitter of Q4.	a. Output voltage remains low. b. Output voltage increases.	a. Q6 open. b. Reconnect emitter lead and proceed to Step 2.
2	Check turn off of Q4 by shorting Q3 emitter to collector.	a. Output voltage remains low. b. Output voltage increases.	a. Q4 shorted. Q17 open. Proceed to Step 4. b. Remove short and proceed to Step 3.
3	Eliminate constant current comparator as a source of trouble by disconnecting anode of CR4.	a. Output voltage increases. b. Output voltage remains low.	a. Check Q2B for open, Q2A for short. Check open strap between A4 and A5. Check R16 for short. b. Reconnect lead and proceed to Step 4.
4	Check turn on of Q3 by shorting Q1A emitter to collector.	a. Output voltage remains low. b. Output voltage increases.	a. Q3 open, Q17 open. b. Check Q1A for open, Q1B for short. Check for open strap between A6 and A7. Check R10 for short.

Table 5-6. Preregulator/Control Circuit Troubleshooting

STEP	MEASURE	RESPONSE	PROBABLE CAUSE
1	Waveform between Taps 4 and 3 of T2.	a. Normal firing pulse. b. No firing pulse.	a. CR35 defective, R102 open. R84, L1, CR28, CR29, T1 defective. b. T2 open. Proceed to Step 2.
2	Waveform between TP23 and TP67.	a. 0 Volts. b. +16 Volt level. c. Waveform distorted.	a. Q19 shorted. C17 shorted. Q18 open. R96, primary T2 open. Proceed to Step 3. b. Q19 open. R96 shorted. Q18 shorted. Proceed to Step 3. c. Proceed to Step 3.
3	Waveform between TP23 and TP66.	a. Amplitude incorrect. b. Period incorrect.	a. C22, CR16, or CR17 defective. R91-R93, R97 R98, R99 incorrect value or open. Proceed to Step 5. b. CR15 defective. Proceed to Step 4.
4	Waveform between TP23 and TP65.	a. Amplitude incorrect. b. Period incorrect.	a. CR13, CR14, CR15 defective. b. CR10, CR11 defective.
5	Waveform between TP23 and TP64.	a. Amplitude incorrect. b. Period incorrect.	a. R100, R101, C23 defective. b. CR9, CR12 defective.

5-67 REPAIR AND REPLACEMENT

5-68 Before servicing a printed wiring board, refer to Section VI of this manual which contains a list of replaceable parts. Before replacing a semiconductor device, refer to Table 5-7 which lists the

special characteristics of selected semiconductors. If the device to be replaced is not listed in Table 5-7, the standard manufacturer's part number listed in Section VI is applicable. After replacing a semiconductor device, refer to Table 5-8 for checks and adjustments that may be necessary.

Table 5-7. Selected Semiconductor Characteristics

REFERENCE DESIGNATOR	CHARACTERISTICS	Ⓢ PART NO.	SUGGESTED REPLACEMENT
Q1	Matched differential amplifier. NPN Si Planar. 70 (min.) h _{FE} I _C = 1mA. V _{CE} = 5V. I _{CO} 0.01μA @ V _{CB0} = 5V.	1854-0229	2N2917 G.E.
Q2	Matched differential amplifier. NPN Si.	1854-0221	2N4045 Union Carbide
CR1, CR22 - 25, CR32, CR34	Si. rectifier, 900mA, 200prv	1901-0327	1N5059 G.E.

Table 5-7. Selected Semiconductor Characteristics (Continued)

REFERENCE DESIGNATOR	CHARACTERISTICS	Ⓢ PART NO.	SUGGESTED REPLACEMENT
CR2-5, CR9-15, CR17, CR18	Si. rectifier, 200mA 180prv	1901-0033	1N485B Sylvania
CR7	Si. diode, 10V, 400mW	1901-0460	1N4830 G. E.
CR8, CR16	Si. rectifier, 400mW, 10prv	1901-0461	1N4828 G. E.
VR3	Zener diode, 40.2V, 1.5W	1902-0431	1N3803 Motorola
VR4	Zener diode, 16.2V, 400mW	1902-0184	1N966 Motorola
VR5	Zener diode, 4.22V, 400mW	1902-3070	1N749 Motorola

Table 5-8. Checks and Adjustments After Replacement of Semiconductor Devices

REFERENCE	FUNCTION	CHECK	ADJUST
Q1	Constant voltage differential amplifier.	Constant voltage (CV) line and load regulation. Zero Volt output.	R6 or R8
Q2	Constant current differential amplifier.	Constant current (CC) line and load regulation. Zero current output.	R25 or R28
Q3, Q4	Mixer and error amplifier.	CV/CC load regulation. CV transient response.	R30
Q6	Series regulator.	CV/CC load regulation.	
Q8, Q9	Reference regulator.	Reference circuit line regulation.	R26
Q10	Clamp circuit.	CC load regulation.	
Q11-15	Meter circuit.	Meter zero. Voltmeter / ammeter tracking.	R63, R72, R56, R38
Q18, Q19	SCR control amplifiers.	Voltage across Q6.	R99
CR1, CR2	Limiting diodes	GV load regulation.	

5-69 ADJUSTMENT AND CALIBRATION

5-70 Adjustment and calibration may be required after performance testing, troubleshooting, or repair and replacement. Perform only those adjustments that affect the operation of the faulty circuit and no others.

5-71 METER ZERO

5-72 Proceed as follows to zero meter:

- a. Turn off instrument (after it has reached normal operating temperature) and allow 30 seconds for all capacitors to discharge.
- b. Insert sharp pointed object (pen point or

awl) into the small indentation near top of round black plastic disc located directly below meter face.

- c. Rotate plastic disc clockwise (cw) until meter reads zero, then rotate ccw slightly in order to free adjustment screw from meter suspension. If pointer moves, repeat Steps (b) and (c).

5-73 VOLTMETER TRACKING

5-74 To calibrate voltmeter tracking, proceed as follows:

- a. To electrically zero meter, set METER switch to highest current position and, with supply on and no load connected, adjust R63 until front

panel meter reads zero.

b. Connect differential voltmeter across supply, observing correct polarity.

c. Set METER switch to highest voltage range and turn on supply. Adjust VOLTAGE control until differential voltmeter reads exactly the maximum rated output voltage.

d. Adjust R72 until front panel meter also indicates maximum rated output voltage.

5-75 AMMETER TRACKING

5-76 To calibrate ammeter tracking, proceed as follows:

a. If meter has not been electrically zeroed, perform Step (a) of Paragraph 5-73.

b. Turn VOLTAGE control fully clockwise, and set METER switch to low current range.

c. Connect decade resistance box in place of R38.

d. Turn on supply (no load connected) and rotate CURRENT controls fully cw.

e. Adjust decade resistance so that ammeter reads zero.

f. Turn off supply and connect test setup as shown on Figure 5-10. Leave S1 open.

g. Turn on supply and adjust CURRENT control until differential voltmeter reads 1.5Vdc.

h. Adjust R56 until front panel meter reads exactly the maximum rated output current.

5-77 CONSTANT VOLTAGE PROGRAMMING CURRENT

5-78 Zero Output Voltage. To calibrate the zero Volt programming accuracy, proceed as follows:

a. Connect differential voltmeter between +S and -S terminals.

b. Short out voltage control by connecting jumper between terminals A6 and -S.

c. Rotate CURRENT controls fully clockwise and turn on supply.

d. Observe reading on differential voltmeter.

e. If it is more positive than 0 Volts, shunt resistor R6 with decade resistance box.

f. Adjust decade resistance until differential voltmeter reads zero, then shunt R6 with resistance value equal to that of the decade resistance.

g. If reading of Step (d) is more negative than 0 Volts, shunt resistor R8 with the decade resistance box.

h. Adjust decade resistance until differential voltmeter reads zero then shunt R8 with resistance value equal to that of the decade box.

5-79 CV Programming Accuracy. To calibrate the constant voltage programming current, proceed as follows:

a. Connect a 0.1%, 48K resistor (96K for Model 6209B) between terminals -S and A6 on rear barrier strip.

b. Disconnect jumper between A7 and A8

(leaving A6 and A7 jumpered) on rear terminal barrier strip.

c. Connect a decade resistance in place of R13.

d. Connect a differential voltmeter between +S and -S and turn on supply.

e. Adjust decade resistance box so that differential voltmeter indicates maximum rated output voltage within $\pm 1.6\text{Vdc}$ for Model 6207B or 3.2Vdc for Model 6209B.

f. Replace decade resistance with resistor of appropriate value in R13 position.

5-80 CONSTANT CURRENT PROGRAMMING CURRENT

5-81 Zero Output Current. To calibrate the zero current programming accuracy, proceed as follows:

a. Connect differential voltmeter between +S and -S terminals.

b. Short out current controls by connecting jumper between terminals A1 and A5.

c. Rotate VOLTAGE control(s) fully clockwise and turn on supply.

d. Observe reading on differential voltmeter.

e. If it is more positive than 0 Volts, shunt resistor R25 with a decade resistance box.

f. Adjust decade resistance until differential voltmeter reads zero, then shunt R25 with resistance value equal to that of decade resistance.

g. If reading of Step (d) is more negative than 0 Volts, shunt resistor R28 with decade resistance.

h. Adjust decade resistance until differential voltmeter reads zero, then shunt R28 with resistance value equal to that of decade box.

5-82 CC Programming Accuracy. To calibrate the constant current programming current, proceed as follows:

a. Connect power supply as shown in Figure 5-10.

b. Remove strap between A3 and A4 (leaving A4 and A5 jumpered).

c. Connect a 0.1%, 15K resistor between A1 and A5.

d. Connect decade resistance box in place of R19.

e. Set METER switch to highest current range and turn on supply.

f. Adjust the decade resistance so that the differential voltmeter indicates $1.5 \pm 0.15\text{Vdc}$.

g. Replace decade resistance with appropriate value resistor in R19 position.

5-83 REFERENCE CIRCUIT ADJUSTMENTS

5-84 Line Regulation. To adjust the line regulation capabilities of the instrument, proceed as follows:

a. Connect the differential voltmeter between +S (common) and 33 (positive).

b. Connect variable voltage transformer be-

tween supply and input power source.

- c. Adjust line to 105Vac.
- d. Connect decade resistance in place of R46.
- e. Turn on supply and adjust VOLTAGE control for maximum rated output voltage.
- f. Adjust decade resistance so that voltage indicated by differential voltmeter does not change more than 1.26mVdc as input line voltage is varied from 105 to 125Vac.
- g. Replace decade resistance with appropriate value resistor in R46 position.

5-85 CONSTANT VOLTAGE TRANSIENT RESPONSE

5-86 To adjust the transient response, proceed as follows:

- a. Connect test setup shown in Figure 5-6.
- b. Repeat Steps (a) through (e) as outlined in

Paragraph 5-31.

- c. Adjust R30 so that the transient response is as shown in Figure 5-7.

5-87 PREREGULATOR TRACKING

5-88 To adjust the preregulator, proceed as follows:

- a. Connect decade resistance in place of R99.
- b. Turn on supply and adjust VOLTAGE control for maximum rated output voltage (no load connected).
- c. Connect dc voltmeter across series regulator (TP23 to TP24).
- d. Adjust decade resistance so that dc voltmeter reads 15Vdc.
- e. Replace decade resistance with appropriate resistor in R99 position.

SECTION VI REPLACEABLE PARTS

6-1 INTRODUCTION

6-2 This section contains information for ordering replacement parts. Table 6-4 lists parts in alpha-numeric order by reference designators and provides the following information:

- a. Reference Designators. Refer to Table 6-1.
- b. Description. Refer to Table 6-2 for abbreviations.
- c. Total Quantity (TQ). Given only the first time the part number is listed except in instruments containing many sub-modular assemblies, in which case the TQ appears the first time the part number is listed in each assembly.
- d. Manufacturer's Part Number or Type.
- e. Manufacturer's Federal Supply Code Number. Refer to Table 6-3 for manufacturer's name and address.
- f. Hewlett-Packard Part Number.
- g. Recommended Spare Parts Quantity (RS) for complete maintenance of one instrument during one year of isolated service.
- h. Parts not identified by a reference designator are listed at the end of Table 6-4 under Mechanical and/or Miscellaneous. The former consists of parts belonging to and grouped by individual assemblies; the latter consists of all parts not immediately associated with an assembly.

6-3 ORDERING INFORMATION

6-4 To order a replacement part, address order or inquiry to your local Hewlett-Packard sales office (see lists at rear of this manual for addresses). Specify the following information for each part: Model, complete serial number, and any Option or special modification (J) numbers of the instrument; Hewlett-Packard part number; circuit reference designator; and description. To order a part not listed in Table 6-4, give a complete description of the part, its function, and its location.

Table 6-1. Reference Designators

A = assembly	E = miscellaneous
B = blower (fan)	electronic part
C = capacitor	F = fuse
CB = circuit breaker	J = jack, jumper
CR = diode	K = relay
DS = device, signaling (lamp)	L = inductor
	M = meter

Table 6-1. Reference Designators (Continued)

P = plug	V = vacuum tube, neon bulb, photocell, etc.
Q = transistor	
R = resistor	
S = switch	VR = zener diode
T = transformer	X = socket
TB = terminal block	Z = integrated circuit or network
TS = thermal switch	

Table 6-2. Description Abbreviations

A = ampere	mfr = manufacturer
ac = alternating current	mod. = modular or modified
assy. = assembly	mtg = mounting
bd = board	n = nano = 10 ⁻⁹
bkt = bracket	NC = normally closed
°C = degree Centigrade	NO = normally open
cd = card	NP = nickel-plated
coef = coefficient	Ω = ohm
comp = composition	obd = order by description
CRT = cathode-ray tube	OD = outside diameter
CT = center-tapped	p = pico = 10 ⁻¹²
dc = direct current	P.C. = printed circuit
DPDT = double pole, double throw	pot. = potentiometer
DPST = double pole, single throw	p-p = peak-to-peak
elect = electrolytic	ppm = parts per million
encap = encapsulated	pvr = peak reverse voltage
F = farad	rect = rectifier
°F = degree Fahrenheit	rms = root mean square
fxd = fixed	Si = silicon
Ge = germanium	SPDT = single pole, double throw
H = Henry	SPST = single pole, single throw
Hz = Hertz	SS = small signal
IC = integrated circuit	T = slow-blow
ID = inside diameter	tan. = tantalum
incnd = incandescent	Ti = titanium
k = kilo = 10 ³	V = volt
m = milli = 10 ⁻³	var = variable
M = mega = 10 ⁶	ww = wirewound
μ = micro = 10 ⁻⁶	W = Watt
met. = metal	

Table 6-3. Code List of Manufacturers

CODE NO.	MANUFACTURER	ADDRESS
00629	EBY Sales Co., Inc.	Jamaica, N. Y.
00656	Aerovox Corp.	New Bedford, Mass.
00853	Sangamo Electric Co. S. Carolina Div.	Pickens, S. C.
01121	Allen Bradley Co.	Milwaukee, Wis.
01255	Litton Industries, Inc.	Beverly Hills, Calif.
01281	TRW Semiconductors, Inc.	Lawndale, Calif.
01295	Texas Instruments, Inc. Semiconductor-Components Div.	Dallas, Texas
01686	RCL Electronics, Inc.	Manchester, N. H.
01930	Amerock Corp.	Rockford, Ill.
02107	Sparta Mfg. Co.	Dover, Ohio
02114	Ferroxcube Corp.	Saugerties, N. Y.
02606	Fenwal Laboratories	Morton Grove, Ill.
02660	Amphenol Corp.	Broadview, Ill.
02735	Radio Corp. of America, Solid State and Receiving Tube Div.	Somerville, N. J.
03508	G. E. Semiconductor Products Dept.	Syracuse, N. Y.
03797	Eldema Corp.	Compton, Calif.
03877	Transitron Electronic Corp.	Wakefield, Mass.
03888	Pyrofilm Resistor Co. Inc.	Cedar Knolls, N. J.
04009	Arrow, Hart and Hegeman Electric Co.	Hartford, Conn.
04072	ADC Electronics, Inc.	Harbor City, Calif.
04213	Caddell & Burns Mfg. Co. Inc.	Mineola, N. Y.
04404	*Hewlett-Packard Co. Palo Alto Div.	Palo Alto, Calif.
04713	Motorola Semiconductor Prod. Inc.	Phoenix, Arizona
05277	Westinghouse Electric Corp. Semiconductor Dept.	Youngwood, Pa.
05347	Ultronix, Inc.	Grand Junction, Colo.
05820	Wakefield Engr. Inc.	Wakefield, Mass.
06001	General Elect. Co. Electronic Capacitor & Battery Dept.	Irmo, S. C.
06004	Bassik Div. Stewart-Warner Corp.	Bridgeport, Conn.
06486	IRC Div. of TRW Inc. Semiconductor Plant	Lynn, Mass.
06540	Amatom Electronic Hardware Co. Inc.	New Rochelle, N. Y.
06555	Beede Electrical Instrument Co.	Penacook, N. H.
06666	General Devices Co. Inc.	Indianapolis, Ind.
06751	Semcor Div. Components, Inc.	Phoenix, Arizona
06776	Robinson Nugent, Inc.	New Albany, Ind.
06812	Torrington Mfg. Co., West Div.	Van Nuys, Calif.
07137	Transistor Electronics Corp.	Minneapolis, Minn.

CODE NO.	MANUFACTURER	ADDRESS
07138	Westinghouse Electric Corp. Electronic Tube Div.	Elmira, N. Y.
07263	Fairchild Camera and Instrument Corp. Semiconductor Div.	Mountain View, Calif.
07387	Birtcher Corp., The	Los Angeles, Calif.
07397	Sylvania Electric Prod. Inc. Sylvania Electronic Systems Western Div.	Mountain View, Calif.
07716	IRC Div. of TRW Inc. Burlington Plant	Burlington, Iowa
07910	Continental Device Corp.	Hawthorne, Calif.
07933	Raytheon Co. Components Div. Semiconductor Operation	Mountain View, Calif.
08484	Breeze Corporations, Inc.	Union, N. J.
08530	Reliance Mica Corp.	Brooklyn, N. Y.
08717	Sloan Company, The	Sun Valley, Calif.
08730	Vemaline Products Co. Inc.	Wyckoff, N. J.
08806	General Elect. Co. Minia- ture Lamp Dept.	Cleveland, Ohio
08863	Nylomatic Corp.	Norrisville, Pa.
08919	RCH Supply Co.	Vernon, Calif.
09021	Airco Speer Electronic Components	Bradford, Pa.
09182	*Hewlett-Packard Co. New Jersey Div.	Berkeley Heights, N. J.
09213	General Elect. Co. Semiconductor Prod. Dept.	Buffalo, N. Y.
09214	General Elect. Co. Semiconductor Prod. Dept.	Auburn, N. Y.
09353	C & K Components Inc.	Newton, Mass.
09922	Burndy Corp.	Norwalk, Conn.
11115	Wagner Electric Corp. Tung-Sol Div.	Bloomfield, N. J.
11236	CTS of Berne, Inc.	Berne, Ind.
11237	Chicago Telephone of Cal. Inc.	So. Pasadena, Calif.
11502	IRC Div. of TRW Inc. Boone Plant	Boone, N. C.
11711	General Instrument Corp Rectifier Div.	Newark, N. J.
12136	Philadelphia Handle Co. Inc.	Camden, N. J.
12615	U. S. Terminals, Inc.	Cincinnati, Ohio
12617	Hamlin Inc.	Lake Mills, Wisconsin
12697	Clarostat Mfg. Co. Inc.	Dover, N. H.
13103	Thermalloy Co.	Dallas, Texas
14493	*Hewlett-Packard Co. Loveland Div.	Loveland, Colo.
14655	Cornell-Dubilier Electronics Div. Federal Pacific Electric Co.	Newark, N. J.
14936	General Instrument Corp. Semicon- ductor Prod. Group	Hicksville, N. Y.
15801	Fenwal Elect.	Framingham, Mass.
16299	Corning Glass Works, Electronic Components Div.	Raleigh, N. C.

*Use Code 28480 assigned to Hewlett-Packard Co., Palo Alto, California

Table 6-3. Code List of Manufacturers (Continued)

CODE NO.	MANUFACTURER	ADDRESS	CODE NO.	MANUFACTURER	ADDRESS
16758	Delco Radio Div. of General Motors Corp.	Kokomo, Ind.	70563	Amperite Co. Inc.	Union City, N.J.
17545	Atlantic Semiconductors, Inc.	Asbury Park, N.J.	70901	Beemer Engrg. Co.	Fort Washington, Pa.
17803	Fairchild Camera and Instrument Corp Semiconductor Div. Transducer Plant	Mountain View, Calif.	70903	Belden Corp.	Chicago, Ill.
17870	Daven Div. Thomas A. Edison Industries McGraw-Edison Co.	Orange, N.J.	71218	Bud Radio, Inc.	Willoughby, Ohio
18324	Signetics Corp.	Sunnyvale, Calif.	71279	Cambridge Thermionic Corp.	Cambridge, Mass.
19315	Bendix Corp. The Navigation and Control Div.	Teterboro, N.J.	71400	Bussmann Mfg. Div. of McGraw & Edison Co.	St. Louis, Mo.
19701	Electra/Midland Corp.	Mineral Wells, Texas	71450	CTS Corp.	Elkhart, Ind.
21520	Fansteel Metallurgical Corp.	No. Chicago, Ill.	71468	I. T. T. Cannon Electric Inc.	Los Angeles, Calif.
22229	Union Carbide Corp. Electronics Div.	Mountain View, Calif.	71590	Globe-Union Inc. Centralab Div.	Milwaukee, Wis.
22753	UID Electronics Corp.	Hollywood, Fla.	71700	General Cable Corp. Cornish Wire Co. Div.	Williamstown, Mass.
23936	Pamotor, Inc.	Pampa, Texas	71707	Coto Coil Co. Inc.	Providence, R. I.
24446	General Electric Co.	Schenectady, N. Y.	71744	Chicago Miniature Lamp Works	Chicago, Ill.
24455	General Electric Co. Lamp Div. of Con- sumer Prod. Group	Nela Park, Cleveland, Ohio	71785	Cinch Mfg. Co. and Howard B. Jones Div.	Chicago, Ill.
24655	General Radio Co.	West Concord, Mass.	71984	Dow Corning Corp.	Midland, Mich.
24681	LTV Electrosystems Inc Memcor/Com- ponents Operations	Huntington, Ind.	72136	Electro Motive Mfg. Co. Inc.	Willimantic, Conn.
26982	Dynacool Mfg. Co. Inc.	Saugerties, N. Y.	72619	Dialight Corp.	Brooklyn, N. Y.
27014	National Semiconductor Corp.	Santa Clara, Calif.	72699	General Instrument Corp.	Newark, N.J.
28480	Hewlett-Packard Co.	Palo Alto, Calif.	72765	Drake Mfg. Co.	Harwood Heights, Ill.
28520	Heyman Mfg. Co.	Kenilworth, N. J.	72962	Elastic Stop Nut Div. of Amerace Esna Corp.	Union, N. J.
28875	IMC Magnetics Corp. New Hampshire Div.	Rochester, N. H.	72982	Erie Technological Products Inc.	Erie, Pa.
31514	SAE Advance Packaging, Inc.	Santa Ana, Calif.	73096	Hart Mfg. Co.	Hartford, Conn.
31827	Budwig Mfg. Co.	Ramona, Calif.	73138	Beckman Instruments Inc. Helipot Div.	Fullerton, Calif.
33173	G. E. Co. Tube Dept.	Owensboro, Ky.	73168	Fenwal, Inc.	Ashland, Mass.
35434	Lectrohm, Inc.	Chicago, Ill.	73293	Hughes Aircraft Co. Electron Dynamics Div.	Torrance, Calif.
37942	P. R. Mallory & Co. Inc.	Indianapolis, Ind.	73445	Amperex Electronic Corp.	Hicksville, N. Y.
42190	Muter Co.	Chicago, Ill.	73506	Bradley Semiconductor Corp.	New Haven, Conn.
43334	New Departure-Hyatt Bearings Div. General Motors Corp.	Sandusky, Ohio	73559	Carling Electric, Inc.	Hartford, Conn.
44655	Ohmite Manufacturing Co.	Skokie, Ill.	73734	Federal Screw Products, Inc.	Chicago, Ill.
46384	Penn Engr. and Mfg. Corp.	Doylestown, Pa.	74193	Heinemann Electric Co.	Trenton, N. J.
47904	Polaroid Corp.	Cambridge, Mass.	74545	Hubbell Harvey Inc.	Bridgeport, Conn.
49956	Raytheon Co.	Lexington, Mass.	74868	Amphenol Corp. Amphenol RF Div.	Danbury, Conn.
55026	Simpson Electric Co. Div. of American Gage and Machine Co.	Chicago, Ill.	74970	E. F. Johnson Co.	Waseca, Minn.
56289	Sprague Electric Co.	North Adams, Mass.	75042	IRC Div. of TRW, Inc.	Philadelphia, Pa.
58474	Superior Electric Co.	Bristol, Conn.	75183	*Howard B. Jones Div. of Cinch Mfg. Corp.	New York, N. Y.
58849	Syntron Div. of FMC Corp.	Homer City, Pa.	75376	Kurz and Kasch, Inc.	Dayton, Ohio
59730	Thomas and Betts Co.	Philadelphia, Pa.	75382	Kilka Electric Corp.	Mt. Vernon, N. Y.
61637	Union Carbide Corp.	New York, N. Y.	75915	Littlefuse, Inc.	Des Plaines, Ill.
63743	Ward Leonard Electric Co.	Mt. Vernon, N. Y.	76381	Minnesota Mining and Mfg. Co.	St. Paul, Minn.
			76385	Minor Rubber Co. Inc.	Bloomfield, N. J.
			76487	James Millen Mfg. Co. Inc.	Malden, Mass.
			76493	J. W. Miller Co.	Compton, Calif.

*Use Code 71785 assigned to Cinch Mfg. Co., Chicago, Ill.

Table 6-3. Code List of Manufacturers (Continued)

CODE NO.	MANUFACTURER	ADDRESS
76530	Cinch	City of Industry, Calif.
76854	Oak Mfg. Co. Div. of Oak	
	Electro/Netics Corp.	Crystal Lake, Ill.
77068	Bendix Corp., Electrodynamics Div.	
		No. Hollywood, Calif.
77122	Palnut Co.	Mountainside, N.J.
77147	Patton-MacGuyer Co.	Providence, R.I.
77221	Phaotron Instrument and Electronic Co.	
		South Pasadena, Calif.
77252	Philadelphia Steel and Wire Corp.	
		Philadelphia, Pa.
77342	American Machine and Foundry Co.	
	Potter and Brumfield Div.	Princeton, Ind.
77630	TRW Electronic Components Div.	
		Camden, N.J.
77764	Resistance Products Co.	Harrisburg, Pa.
78189	Illinois Tool Works Inc. Shakeproof Div.	
		Elgin, Ill.
78452	Everlock Chicago, Inc.	Chicago, Ill.
78488	Stackpole Carbon Co.	St. Marys, Pa.
78526	Stanwyck Winding Div. San Fernando	
	Electric Mfg. Co. Inc.	Newburgh, N.Y.
78553	Tinnerman Products, Inc.	Cleveland, Ohio
78584	Stewart Stamping Corp.	Yonkers, N.Y.
79136	Waldes Kohinoor, Inc.	L. I. C., N.Y.
79307	Whitehead Metals Inc.	New York, N.Y.
79727	Continental-Wirt Electronics Corp.	
		Philadelphia, Pa.
79963	Zierick Mfg. Co.	Mt. Kisco, N.Y.
80031	Mepco Div. of Sessions Clock Co.	
		Morristown, N.J.
80294	Bourns, Inc.	Riverside, Calif.
81042	Howard Industries Div. of Msl Ind. Inc.	
		Racine, Wisc.
81073	Grayhill, Inc.	La Grange, Ill.
81483	International Rectifier Corp.	
		El Segundo, Calif.
81751	Columbus Electronics Corp.	Yonkers, N.Y.
82099	Goodyear Sundries & Mechanical Co. Inc.	
		New York, N.Y.
82142	Airco Speer Electronic Components	
		Du Bois, Pa.
82219	Sylvania Electric Products Inc.	
	Electronic Tube Div. Receiving	
	Tube Operations	Emporium, Pa.
82389	Switchcraft, Inc.	Chicago, Ill.
82647	Metals and Controls Inc. Control	
	Products Group	Attleboro, Mass.
82866	Research Products Corp.	Madison, Wis.
82877	Rotron Inc.	Woodstock, N.Y.
82893	Vector Electronic Co.	Glendale, Calif.
83058	Carr Fastener Co.	Cambridge, Mass.
83186	Victory Engineering Corp.	
		Springfield, N.J.
83298	Bendix Corp. Electric Power Div.	
		Eatontown, N.J.
83330	Herman H. Smith, Inc.	Brooklyn, N.Y.
83385	Central Screw Co.	Chicago, Ill.
83501	Gavitt Wire and Cable Div. of	
	Amerace Esna Corp.	Brookfield, Mass.

CODE NO.	MANUFACTURER	ADDRESS
83508	Grant Pulley and Hardware Co.	
		West Nyack, N.Y.
83594	Burroughs Corp. Electronic	
	Components Div.	Plainfield, N.J.
83835	U. S. Radium Corp.	Morristown, N.J.
83877	Yardeny Laboratories, Inc.	
		New York, N.Y.
84171	Arco Electronics, Inc.	Great Neck, N.Y.
84411	TRW Capacitor Div.	Ogallala, Neb.
86684	RCA Corp. Electronic Components	
		Harrison, N.J.
86838	Rummel Fibre Co.	Newark, N.J.
87034	Marco & Oak Industries a Div. of Oak	
	Electro/netics Corp.	Anaheim, Calif.
87216	Philco Corp. Lansdale Div.	Lansdale, Pa.
87585	Stockwell Rubber Co. Inc.	
		Philadelphia, Pa.
87929	Tower-Olschan Corp.	Bridgeport, Conn.
88140	Cutler-Hammer Inc. Power Distribution	
	and Control Div. Lincoln Plant	
		Lincoln, Ill.
88245	Litton Precision Products Inc, USECO	
	Div. Litton Industries	Van Nuys, Calif.
90634	Gulton Industries Inc.	Metuchen, N.J.
90763	United-Car Inc.	Chicago, Ill.
91345	Miller Dial and Nameplate Co.	
		El Monte, Calif.
91418	Radio Materials Co.	Chicago, Ill.
91506	Augat, Inc.	Attleboro, Mass.
91637	Dale Electronics, Inc.	Columbus, Neb.
91662	Elco Corp.	Willow Grove, Pa.
91929	Honeywell Inc. Div. Micro Switch	
		Freeport, Ill.
92825	Whitso, Inc.	Schiller Pk., Ill.
93332	Sylvania Electric Prod. Inc. Semi-	
	conductor Prod. Div.	Woburn, Mass.
93410	Essex Wire Corp. Stemco	
	Controls Div.	Mansfield, Ohio
94144	Raytheon Co. Components Div.	
	Ind. Components Oper.	Quincy, Mass.
94154	Wagner Electric Corp.	
	Tung-Sol Div.	Livingston, N.J.
94222	Southco Inc.	Lester, Pa.
95263	Leecraft Mfg. Co. Inc.	L. I. C., N.Y.
95354	Methode Mfg. Co.	Rolling Meadows, Ill.
95712	Bendix Corp. Microwave	
	Devices Div.	Franklin, Ind.
95987	Weckesser Co. Inc.	Chicago, Ill.
96791	Amphenol Corp. Amphenol	
	Controls Div.	Janesville, Wis.
97464	Industrial Retaining Ring Co.	
		Irvington, N.J.
97702	IMC Magnetics Corp. Eastern Div.	
		Westbury, N.Y.
98291	Sealectro Corp.	Mamaroneck, N.Y.
98410	ETC Inc.	Cleveland, Ohio
98978	International Electronic Research Corp.	
		Burbank, Calif.
99934	Renbrandt, Inc.	Boston, Mass.

Table 6-4. Replaceable Parts

REF. DESIG.	DESCRIPTION	TQ	MFR. PART NO.	MFR. CODE	Ⓢ PART NO.	RS
C1	fxd, elect .47μf 400Vdc	1	220P47494B	56289	0160-3356	1
C2	fxd, film .01μf 400Vdc	1	663-UW	84411	0160-0381	1
C3	fxd, film .01μf 200Vdc	2	192P10392	56289	0160-0161	1
C4, 8, 11, 13, 15, 16, 21, 25	NOT ASSIGNED	-	-	-	-	-
C5	fxd, film .0022μf 200Vdc	2	192P22292	56289	0160-0154	1
C6	fxd, elect 20μf 15Vdc	2	30D206G015BB4	56289	0180-0300	1
C7	fxd, film .0022μf 200Vdc		192P22292	56289	0160-0154	
C9	fxd, elect 4.7μf 35Vdc	1	150D475X903B52	56289	0180-0100	1
C10	fxd, elect 100μf 50Vdc	1		09182	0180-1852	1
C12	fxd, elect 490μf 85Vdc	1		09182	0180-1888	1
C14	fxd, elect 125μf 450Vdc	1		09182	0180-1883	1
C17	fxd, film .1μf 200Vdc	1	192P10492	56289	0160-0168	1
C18	fxd, film .01μf 200Vdc		192P10392	56289	0160-0161	
C19	fxd, film 1μf 400Vdc	1	118P1050453	56289	0160-2467	1
C20	fxd, film 25μf 475Vdc	1		09182	0180-1848	1
C22	fxd, elect 1μf 35Vdc	1	150D105X9035A2	56289	0180-0291	1
C23, 24	fxd, elect 5μf 65Vdc	2		09182	0180-1836	1
CR1	Rect. Si. 900mA 400prv	3	1N5060	03508	1901-0328	3
CR2-5	Rect. Si. 200mA 180prv	18		09182	1901-0033	8
CR6, 31	NOT ASSIGNED	-	-	-	-	-
CR7	Diode, Si. 2.4V @ 100mA	1	1N4830	03508	1901-0460	1
CR8	Rect. Si. 200mA 10prv	2	1N4828	03508	1901-0461	2
CR9-15	Rect. Si. 200mA 180prv			09182	1901-0033	
CR16	Rect. Si. 200mA 10prv			09182	1901-0461	
CR17-21	Rect. Si. 200mA 180prv			09182	1901-0033	
CR22-25	Rect. Si. 900mA 200prv	4	1N5059	03508	1901-0327	4
CR26-29	Rect. Si. 400mA 800prv	4	1N3256	02735	1901-0388	4
CR30	Rect. Si. 200mA 180prv			09182	1901-0033	
CR32	Rect. Si. 900mA 400prv		1N5060	03508	1901-0328	
CR33	Rect. Si. 200mA 180prv			09182	1901-0033	
CR34	Rect. Si. 900mA 400prv		1N5060	03508	1901-0328	
CR35	SCR Si. 2A 600prv	1	2N4102	02735	1884-0044	1
DS1	Lamp, Neon	1	599-124	72765	1450-0048	1
F1	Fuse Cartridge 2A @ 250V 3AG	1	312002	75915	2110-0002	5
L1	Coil	1		09182	9100-1854	1
Q1	SS NPN Diff. Amp Si.	1		09182	1854-0229	1
Q2	NPN Diff. Amp Si.	1		09182	1854-0221	1
Q3, 4	SS PNP Si.	7		09182	1853-0099	6
Q5, 7, 16	NOT ASSIGNED	-	-	-	-	-
Q6	Power NPN	1		09182	1854-0225	1
Q8	SS PNP Si.			09182	1853-0099	
Q9	SS NPN Si.	6		09182	1854-0071	6
Q10	SS PNP Si.			09182	1853-0099	
Q11	SS NPN Si.			09182	1854-0071	
Q12	SS PNP Si.			09182	1853-0099	
Q13	SS NPN Si.			09182	1854-0071	
Q14, 15	SS PNP Si.			09182	1853-0099	
Q17-19	SS NPN Si.			09182	1854-0071	

REF. DESIG.	DESCRIPTION	TQ	MFR. PART NO.	MFR. CODE	Ⓢ PART NO.	RS
R1	fxd, ww 2K _Ω ±5% 3W 20ppm	2	242E2025	56289	0811-1806	1
R2	fxd, met. film 6.2K _Ω ±1% 1/8W	2	Type CEA T-O	07716	0698-5087	1
R3, 4	fxd, met. film 20K _Ω ±1% 1/8W	2	Type CEA T-O	07716	0757-0449	1
R5	fxd, met. film 1.5K _Ω ±1% 1/8W	5	Type CEA T-O	07716	0757-0427	1
R6	fxd, comp 360K _Ω ±5% ½W	2	EB-3645	01121	0686-3645	1
R7	fxd, comp 430K _Ω ±5% ½W	1	EB-4345	01121	0686-4345	1
R8	fxd, comp 560K _Ω ±5% ½W	2	EB-5645	01121	0686-5645	1
R9	fxd, comp 1Meg ±5% ½W	1	EB-1055	01121	0686-1055	1
R10	var. ww 100K _Ω 10 Turn	1		09182	2100-1869	1
R11, 17, 27, 32, 35-37, 39, 40, 78, 79	NOT ASSIGNED	-	-	-	-	-
R12	fxd, ww 2K _Ω ±5% 3W 20ppm		242E2025	56289	0811-1806	
R13	fxd, comp (Selected) ±5% ½W	3	Type EB (obd)	01121		1
R14	fxd, comp 3.3K _Ω ±5% ½W	1	EB-33G5	01121	0686-0335	1
R15	fxd, met. ox. 91K _Ω ±5% 2W	1	Type C42S	16299	0698-3658	1
R16	var. ww Dual 18K-200 _Ω	1		09182	2100-2068	1
R18	fxd, ww 65K _Ω ±1% ½W	1	E30	01686	0811-2077	1
R19	fxd, comp (Selected) ±5% ½W		Type EB (obd)	01121		
R20	fxd, met. film 1K _Ω ±1% ¼W	2	Type CEB T-O	07716	0757-0338	1
R21	fxd, comp 390 _Ω ±5% ½W	1	EB-3915	01121	0686-3915	1
R22, 23	fxd, comp 61.9K _Ω ±1% 1/8W	2	Type CEA T-O	07716	0757-0460	1
R24	fxd, met. film 43K _Ω ±1% 1/8W	1	Type CEA T-O	07716	0698-5090	1
R25	fxd, comp 360K _Ω ±5% ½W		EB-3645	01121	0686-3645	
R26	fxd, met. film 1.5K _Ω ±1% 1/8W		Type CEA T-O	07716	0757-0427	
R28	fxd, comp 560K _Ω ±5% ½W		EB-5645	01121	0686-5645	
R29	fxd, met. film 1.5K _Ω ±1% 1/8W		Type CEA T-O	07716	0757-0427	
R30	var. ww 5K _Ω (Modify)	1	Type 110-F4	11236	2100-1824	1
R31	fxd, comp 4.7K _Ω ±5% ½W	1	EB-4725	01121	0686-4725	1
R33, 34	fxd, comp 6.2K _Ω ±5% ½W	2	EB-6225	01121	0686-6225	1
R38	fxd, comp (Selected) ±5% ½W		Type EB (obd)	01121		
R41	fxd, comp 12K _Ω ±5% ½W	1	EB-1235	01121	0686-1235	1
R42	fxd, comp 6.8K _Ω ±5% ½W	1	EB-6825	01121	0686-6825	1
R43	fxd, met. film 510 _Ω ±1% ¼W	1	Type CEB T-O	07716	0698-5145	1
R44	fxd, comp 47K _Ω ±5% ½W	1	EB-4735	01121	0686-4735	1
R45	fxd, comp 5.1K _Ω ±5% ½W	1	EB-5125	01121	0686-5125	1
R46	fxd, comp 100K _Ω ±5% ½W	1	EB-1045	01121	0686-1045	1
R47	fxd, comp 560 _Ω ±5% ½W	1	EB-5615	01121	0686-5615	1
R48	fxd, met. film 1K _Ω ±1% ¼W		Type CEB T-O	07716	0757-0338	
R49	fxd, ww 15K _Ω ±5% 10W	1	247E1535	56289	0815-0045	1
R50	fxd, comp 10 _Ω ±5% ½W	1	EB-1005	01121	0686-1005	1
R51	fxd, comp 30K _Ω ±5% ½W	1	EB-3035	01121	0686-3035	1
R52	fxd, comp 22K _Ω ±5% ½W	1	EB-2235	01121	0686-2235	1
R53	fxd, met. film 3K _Ω ±1% 1/8W	5	Type CEA T-O	07716	0757-1093	1
R54	fxd, ww 15 _Ω ±1% 10W	1	10SX	63743	0811-1897	1
R55	fxd, met. film 42.2 _Ω ±1% 1/8W	1	Type CEA T-O	07716	0757-0316	1
R56	var. ww 1K _Ω (Modify)	1	Type 110-F4	11236	2100-0391	1
R57	fxd, met. film 900 _Ω ±1% 1/8W	2	Type CEA T-O	07716	0757-1099	1
R58, 59	fxd, met. film 100 _Ω ±1% 1/8W	2	Type CEA T-O	07716	0757-0401	1
R60	fxd, met. film 900 _Ω ±1% 1/8W		Type CEA T-O	07716	0757-1099	
R61	fxd, met. film 383K _Ω ±1% ½W	1	Type CEC T-O	07716	0757-0133	1
R62	fxd, met. film 750 _Ω ±1% 1/8W	1	Type CEA T-O	07716	0757-0420	1
R63	var. ww 5K _Ω	1	Type 110-F4	11236	2100-1824	1
R64, 65	fxd, met. film 12K _Ω ±1% 1/8W	2	Type CEA T-O	07716	0698-5088	1

REF. DESIG.	DESCRIPTION	TQ	MFR. PART NO.	MFR. CODE	Ⓢ PART NO.	RS
R66, 67	fxd, met. film 3.40K Ω \pm 1% $\frac{1}{4}$ W	2	Type CEB T-O	07716	0698-4642	1
R68, 69	fxd, met. film 365 Ω \pm 1% $\frac{1}{4}$ W	2	Type CEB T-O	07716	0757-0723	1
R70, 71	fxd, met. film 3K Ω \pm 1% 1/8W		Type CEA T-O	07716	0757-1093	
R72	var. ww 250 Ω (Modify)	1	Type 110-F4	11236	2100-0439	1
R73	fxd, met. film 750 Ω \pm 1% 1/8W	1	Type CEA T-O	07716	0757-0420	1
R74	fxd, met. film 9.09K Ω \pm 1% 1/8W	1	Type CEA T-O	07716	0757-0288	1
R75	fxd, met. film 3K Ω \pm 1% 1/8W		Type CEA T-O	07716	0757-1093	
R76, 77	fxd, met. film 1.5K Ω \pm 1% 1/8W		Type CEA T-O	07716	0757-0427	
R80	fxd, comp 33K Ω \pm 5% $\frac{1}{2}$ W	1	EB-3335	01121	0686-3335	1
R81	fxd, ww 100 Ω \pm 5% 5W	1	Type 5XM	56289	0812-0018	1
R82	fxd, comp 3.3M \pm 5% $\frac{1}{2}$ W	1	EB-3355	01121	0686-3355	1
R83	fxd, comp 1.6K Ω \pm 5% $\frac{1}{2}$ W	1	EB-1625	01121	0686-1625	1
R84	fxd, ww 2 Ω \pm 5% 3W 20ppm	1	242E2R05	56289	0811-1831	1
R85	fxd, met. film 3K Ω \pm 1% 1/8W		Type CEA T-O	07716	0757-1093	
R86	fxd, met. film 6.2K Ω \pm 1% 1/8W		Type CEA T-O	07716	0698-5087	
R87	fxd, ww 3K Ω \pm 5% 3W 20ppm	1	242E3025	56289	0812-0010	1
R88	fxd, comp 1.5K Ω \pm 5% 1W	1	GB-1525	01121	0689-1525	1
R89	fxd, ww 220 Ω \pm 5% 2W	1	Type BWH	07716	0811-1763	1
R90	fxd, comp 6.2K Ω \pm 5% 1W	1	GB-6225	01121	0689-6225	1
R91	fxd, comp 39K Ω \pm 5% $\frac{1}{2}$ W	1	EB-3935	01121	0686-3935	1
R92	fxd, comp 43K Ω \pm 5% $\frac{1}{2}$ W	1	EB-4335	01121	0686-4335	1
R93	fxd, comp 10K Ω \pm 5% $\frac{1}{2}$ W	2	EB-1035	01121	0686-1035	1
R94	fxd, comp 120K Ω \pm 5% $\frac{1}{2}$ W	1	EB-1245	01121	0686-1245	1
R95	fxd, comp 10K Ω \pm 5% $\frac{1}{2}$ W		EB-1035	01121	0686-1035	
R96	fxd, comp 3.9K Ω \pm 5% $\frac{1}{2}$ W	1	EB-3925	01121	0686-3925	1
R97	fxd, comp 16K Ω \pm 5% $\frac{1}{2}$ W	1	EB-1635	01121	0686-1635	1
R98	fxd, comp 2.2K Ω \pm 5% $\frac{1}{2}$ W	1	EB-2225	01121	0686-2225	1
R99	fxd, comp 11K Ω \pm 5% $\frac{1}{2}$ W	1	EB-1135	01121	0686-1135	1
R100	fxd, comp 330 Ω \pm 5% 1W	1	GB-3315	01121	0689-3315	1
R101	fxd, comp 22 Ω \pm 5% $\frac{1}{2}$ W	1	EB-2205	01121	0686-2205	1
R102	fxd, comp 100 Ω \pm 5% $\frac{1}{2}$ W	1	EB-1015	01121	0686-1015	1
R103	fxd, comp 1K Ω \pm 5% $\frac{1}{2}$ W	1	EB-1025	01121	0686-1025	1
R104	fxd, comp 4.7 Ω \pm 5% $\frac{1}{2}$ W	1	EB-0475	01121	0698-0001	1
S1	Switch, SPST ON/OFF	1	T110-72	73559	3101-1055	1
S2	Meter Switch, Wafer	1		09182	3100-1910	1
T1	Transformer, Power	1		09182	9100-1825	1
T2	Transformer, Pulse	1		09182	9100-1824	1
T3	Transformer, Bias	1		09182	9100-1826	1
VR1, 2	Diode, zener 6.2V	2	1N821	06486	1902-0761	2
VR3	Diode, zener 40.2V 1.5W	1		09182	1902-0431	1
VR4	Diode, zener 16.2V 400mW	1		09182	1902-0184	1
VR5, 6	Diode, zener 4.22V 400mW	2		09182	1902-3070	2
MISCELLANEOUS						
	Bracket, Heat Sink	2		09182	5000-6060	
	Heat Sink	1		09182	5020-5566	
	Guard, Barrier Strip	1		09182	5060-6181	
	Cover	2		09182	5000-6061	
	Blank Panel, Front	1		09182	5000-6062	
	Knob, Black with Pointer	1		09182	0370-0101	1
	Knob, Red	1		09182	0370-0179	1

REF. DESIG.	DESCRIPTION	TQ	MFR. PART NO.	MFR. CODE	Ⓢ PART NO.	RS
	Knob, Black with Arrow	1		09182	0370-0084	1
	Knob, Black	1		09182	0370-0137	1
	Meter, 0-400V 0-120mA	1		09182	1120-1233	1
	Spring, Meter	4		09182	1460-0720	
	Bezel, Meter	1		09182	4040-0295	1
	5 Way Binding Post, Maroon	1	DF21Mn	58474	1510-0040	1
	5 Way Binding Post, Black	2	DF21BC	58474	1510-0039	1
	Fastener, Pilot Light	1	C17373-012-24B	89032	0510-0123	1
	Barrier Strip	1		09182	0360-1234	1
	Strain Relief Bushing	1	SR-5P-1	28520	0400-0013	1
	Cable Clamp	3	T4-4	79307	1400-0330	1
	Line Cord	1	KH-4096	70903	8120-0050	1
	Jumper, Barrier Strip	8	422-13-11 013	71785	0360-1143	2
	Fuse Holder	1	342014	75915	1400-0084	1
	Chassis, Right	1		09182	5060-6118	1
	Chassis, Left	1		09182	5060-6119	1
	Printed Circuit Board (Blank)	1		09182	5020-5570	1
	P. C. Board (Includes Components)	1		09182	06209-60020	1
	Rubber Bumper, P. C. B.	3	4072	87575	0403-0086	1
	Mica Insulator, Q6	1	734	08530	0340-0174	1
	Insulator, Transistor Pin, Q6	2		09182	0340-0166	1
	Insulator, Q6	2		09182	0340-0168	1
	Rubber Bumper, Feet	4	MB50	87575	0403-0088	1

SECTION VII CIRCUIT DIAGRAMS

This section contains the circuit diagrams necessary for the operation and maintenance of this power supply. Included are:

a. Component Location Diagram, Figure 7-1, which shows the physical location and reference designator of parts mounted on the printed

wiring board.

b. Schematic Diagram, Figure 7-2, which illustrates the circuitry for the entire power supply. Voltages are given adjacent to test points, identified by encircled numbers on the schematic and printed wiring board.

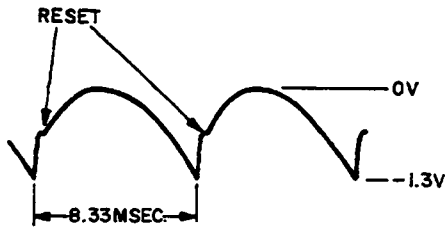

TEST POINTS 66-23
(NO LOAD)

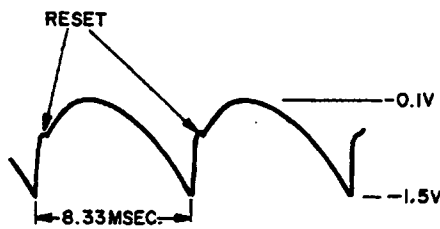

TEST POINTS 66-23
(FULL LOAD)

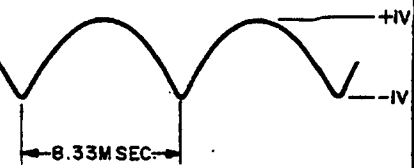

TEST POINTS 66-23
(NO LOAD, 10V OUTPUT)

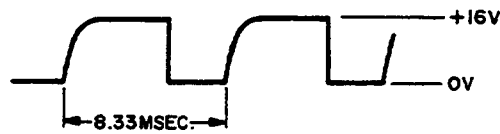

TEST POINTS 67-23

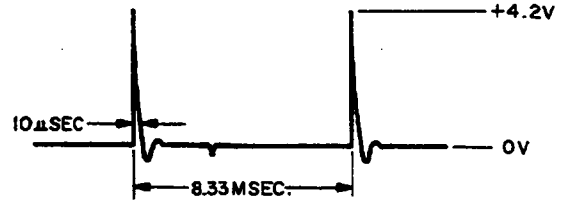

TEST POINTS 68-(T2-4)

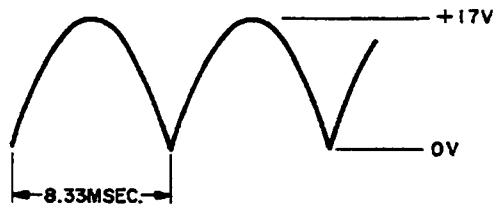

TEST POINTS 23 - CR9 & CR12 (CATHODE)

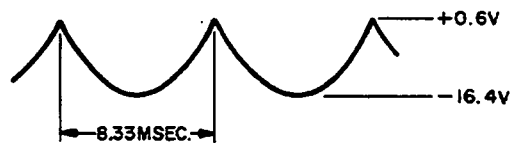

TEST POINTS 65 - +S

NOTES:

1. ALL WAVEFORMS TAKEN WITH 115VAC, 60Hz, SINGLE-PHASE INPUT AT MAXIMUM RATED OUTPUT VOLTAGE WITH NO LOAD CONNECTED (EXCEPT B AND C INDICATED). WAVEFORM AMPLITUDES ARE TYPICAL $\pm 10\%$.
2. OSCILLOSCOPE DC COUPLED AND REFERENCED TO TEST POINT 23 UNLESS OTHERWISE INDICATED.
3. FOR CLARITY, WAVEFORMS ARE NOT DRAWN TO SCALE.

APPENDIX A MANUAL BACKDATING CHANGES

Manual backdating changes describe changes necessary to adapt this manual to earlier instruments. To adapt the manual to serial numbers prior to 7F1117 inspect the following table for your serial number and then make the appropriate changes. For serial numbers 7F1166 and up check for inclusion of change sheet.

SERIAL		MAKE CHANGES
Prefix	Number	
7F	1016 - 0892	1
7F	0891 - 0452	1, 2
7F	0451 - 0402	1, 2, 3
6J	0401 - 0251	1, 2, 3, 4
6J	0250 - 0101	1, 2, 3, 4, 5

CHANGE 1:

In replaceable parts list and on schematic, make the following changes:

R99: Change to nominal value 12K Ω , A. B., $\text{\textcircled{C}}$ Part No. 0686-1235.

CHANGE 2:

In replaceable parts list and on schematic, make the following changes:

C1: Change to 1 μ f 450V $\text{\textcircled{C}}$ Part No. 0180-1845.

CHANGE 3:

In replaceable parts list and on schematic, make

the following changes:

VR6: Delete

R40: Add, 900 Ω \pm 1% 1/8W, $\text{\textcircled{C}}$ Part No. 0757-1099. Connect R40 in place of VR6.

CHANGE 4:

In replaceable parts list and on schematic, make the following changes:

C5: Change to .001 μ f 200V, $\text{\textcircled{C}}$ Part No. 0160-0153.

C25: Add, .001 μ f 200V, Sprague, $\text{\textcircled{C}}$ Part No. 0160-0153. Connect C25 from junction of R96 and pulse transformer to base of Q18.

CR19: Delete (open).

CR21: Delete (open).

R103: Delete (open).

R104: Delete (short).

CHANGE 5:

In replaceable parts list and on schematic, make the following changes:

R31: Change to 1K Ω \pm 5% $\frac{1}{2}$ W, A. B., $\text{\textcircled{C}}$ Part No. 0686-1025.

5-19-69



Order Part Number
06209-90003

E0669 U0589

Printed in USA

Manufacturing Part Number

06209-90003



